



国际山地旅游联盟
International Mountain Tourism Alliance

INTERNATIONAL GUIDEBOOK FOR THE DEVELOPMENT OF HIKING

Territory & Trails



Your Trail Project

PART 2

March 2021

Author:

Serge KOENIG - 高宁

Former Mountain Attaché to the French Ambassador to China

Former "Outdoor sports and sustainable development" advisor to the Minister of Sports

Former guide-professor of ENSA (National School of Ski & Mountaineering), Alpine Guide at the
Compagnie de Chamonix

Guest lecturer of tourism & sport at the Savoie Mont-Blanc University



熊猫国际
SPORTS TOURISM MEDIA

Operated by IMTA

March 2021

CONTENT CONTRIBUTORS FOR THIS IMTA REPORT

- Frédéric BIEBER:** *Engineering and development division at the Alsace Development Tourism agency (ADT)*
- Benjamin BILLET:** *General secretary of the European Network of Outdoor Sports (ENOS)*
- Laurent BOIVEAU:** *nature photographer, Himalayan and Madagascar hiking expert <http://www.tekenessi.fr/>*
- Lieutenant Stéphane BOZON:** *Commander of the mountain rescue team (PGHM) of Haute-Savoie in the Alps*
- Maurice BRUZEK:** *Former President of the Outdoor Sports Committee of the French Olympic Committee*
- François BURTHEY:** *Hiking-guide trainer at the National Mountain Sports School (ENSM), Chamonix, France*
- Yohan CAZAUBON:** *Master's degree STAPS in « Sport management » from the University Rennes 2, France*
- Claire CRUBLET:** *Doctoral student in sociology of sport - <https://perso.univ-rennes2.fr/claire.crublet> - France*
- Arnaud DUCORNET:** *Vice-President of the European Rambling Federation*
- Awadhesh K DAS:** *Board member of Nepal Tourism*
- Claude JACOT:** *French National observatory for mountain safety (SNOSM) and Deputy Mayor of Chamonix*
- Jean-KLINKERT:** *Honorary President of the hiking "Club Vosgien of Colmar"*
- Séverine IKKAWI:** *Director of routes and Marketing of the national French Hiking Federation (FFRP)*
- Valérie LECURIEUX:** *In charge of trails and planning department of the national French Hiking Federation (FFRP)*
- Yves LESPERAT:** *Former National technical advisor of the French Hiking Federation (FFRP)*
- François MARSIGNY:** *Director of the mountaineering department of the French Mountain and Ski National School (ENSA)*
- Boris MICIC:** *President of the European Rambling Association (ERA-EWV-FERP)*
- Domenico PANDOLFO:** *President of the national Italian Hiking Federation, Vice-president of the European Federation*
- Jules PIJOURLET:** *Director of the sustainable development and territories relations the UTMB® Group*
- Bill & Marika ROBERSON:** *Presidents of International Nature and Cultural Adventures - www.inca.com*
- Eric THIOLIERE:** *Hiking guide at the Compagnie of Chamonix, Technical trail adviser of Haute-Savoie In Alpes*
- Roger M. VALENCIA:** *Former Minister of tourism and Former Minister of Culture of Peru*

PROOFREADING COMMITTEE

- François BURTHEY:** *Agricultural engineer "Forestry and wildlife expertise", Former President of international UIMLA*
- Claire CRUBLET:** *Doctoral student in sociology of sport at the University Rennes 2*
- Valérie LECURIEUX:** *In charge of trails and planning of the national French Hiking Federation (FFRP)*
- Yves LESPERAT:** *Former Technical National advisor of the French Hiking Federation (FFRP)*
- Michel RICARD:** *Head of the UNESCO Chair of Education, Training and Research for Sustainable Development*
- Eric THIOLIERE:** *Hiking guide at the Compagnie of Chamonix, Technical trail adviser of Haute-Savoie in the Alps*
- WANG Xiaoning:** *Master's degree in sports & leisure law of the University Savoie-Mont-Blanc, President Panda Tourism*

LOGOS OF SOME CONTRIBUTING COMMUNITIES AND ASSOCIATIONS IN THE CONTENT OF THE REPORT





SUMMARY

Part 2: Your Trail Project

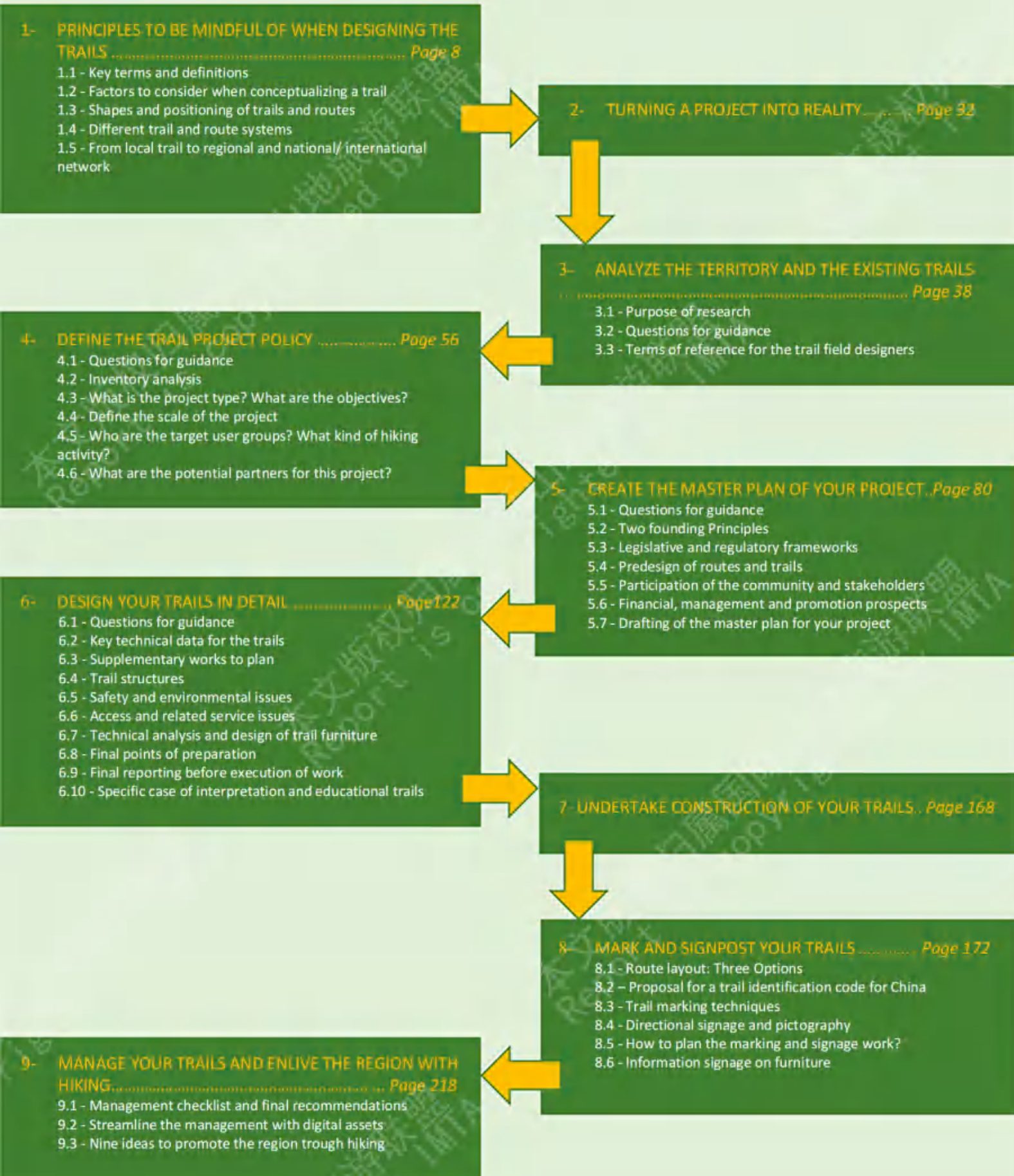

PRINCIPLES TO BE MINDFUL OF WHEN DESIGNING THE TRAILS

1

This chapter provides you with general information on how to undertake a trail construction project.

The first step is to speak and understand the common language on hiking issues. Next is to learn about the factors that make a good trail, the types of hikes and the shapes of the routes, the layout of the route networks, etc. These principles are essential for building a quality hiking trail.

CHAPTER SUMMARY

- 1.1 Key terms and definitions
- 1.2 Factors to consider when conceptualizing a trail
- 1.3 Shapes and positioning of trails and routes
- 1.4 Different trail and route systems
- 1.5 From local trail to regional and national/ international network



1.1 - Key terms and definitions

Without a common language and alignment of perception, projects cannot be realized, as the most critical thing in cross-functional work is that key elements are understood and perceived the same by all stakeholders. To this end, here are some essential terminology to help you with your project.

Users	Refers to hikers, walkers, and trail users
The road	Corresponds to the paths shaped and paved for the traffic of mechanized and/or motorized vehicles
The trail and the path	Natural and unpaved paths, following the terrain's surface, designed to travel on foot, on horseback, by bicycle, some can be driven by 4X4 car depending on the width.
The trails network	This is a mesh of connecting routes (paths, trails, greenways, roads) intertwined and interconnected by junctions. We speak of a network of paths, a network of junctions or a network of routes
The itinerary	Refers to a route followed by the hiker, allowing him/her to go from one point to another by choosing sections of trail among the possible combinations within the trails network and junctions. The objective of the network is to allow one point to be linked to another by means of various combinations, thus diversifying experiences on the same area. The itinerary can be designed by the planner who marks it out and make the trails network a tourist offer intended at visitors-hikers. The hikers can either follow this marked route or design his or her own itinerary/route according to a combination of his/her choice.
The hike	The activity that consists of walking. It sometimes might also refer to a hiking route or a trail.
The trail experience	This is the enjoyment and excitement that the hiker feels when using the trail (landscapes, colors, smells of nature, escarpments, breathtaking passages, cross-cultural experiences, etc.)
The hiking experience	This satisfaction relates more to the concept of the activity than to the concept of the trail, like the "hikes ++" which offer unique experiences: for example, hiking with an accompanying animal who help carry the luggage, or hiking with a storyteller guide who tells local stories and legends... (refer to P1 - Chapter 8)*.

The terms "trail", "path", "itinerary", "route" and "hike" are sometimes used to express the same thing.



©Serge Koenig: trail surveying in Huangshan with Panda Tourism and the local government, Anhui (China 2018)



©Serge Koenig: hiking in Chamonix (France 2020)

1.2 - Factors to consider when conceptualizing a trail

ARCHITECTURAL HERITAGE

Putting emphasis on local heritage, which helps to enhance a territory as a whole, is a highly regarded strategy. As the soul of the region, local heritage displays the identity of the area and can make a destination unique in comparison to others. Like natural resources, it punctuates the itinerary and can also become the main objective of the hike.



THE VALUE OF THE SCENERY

This can be said to be the major asset of a hike (panoramic views, impressive sites, specific characteristics of the territory...). It can also be the link between several centers of interest (heritage or other). Its value must therefore be considered with regard to the itinerary as a whole. Generally speaking, seeking out diversity in the paths and environment crossed allows for permanent discovery and prevents the hiker from getting bored during the hike. In any case, the natural environment and a pleasant ambiance remain the most sought after by trail users.



BIODIVERSITY

Being able to see and observe wild flora and fauna is one of the greatest enjoyments of a hike. A hiking trail that benefits from an environment rich in biodiversity is today a considerable asset for developing gentle activities such as walking, and for relearning the link that connects us to nature.



NOTABLE NATURAL BEAUTY SPOTS

Summits, waterfalls, lakes, geological features, particular flora and others are all examples of assets that a trail can be developed around. They mark the terrain, are important stages of the hike, and can even be the purpose of the hike. They can be seen as the spine of the itinerary. If the environment is exceptional, the hike can become an emblematic offer and carry the image for the tourism promotion of the region.



TRAIL SECTIONS THAT ALREADY EXIST

If hiking practices already exist on the territory, the notion of integrating trail sections that are most popular with hikers will also guarantee the success of new route projects. The collection of geo-localized data from these hikers (if available) can help to know which are the trails they frequent the most.



SENSITIVE AREAS

Fragile areas are generally important points of interest, provided that all protective measures are taken into account. They can be used to introduce hikers to rare phenomena or ecosystems by combining an educational and awareness-raising aspect. They represent an additional asset that may be worth integrating into the design of a route.



APPROPRIATENESS OF THE DIFFICULTY TO THE PROFILE OF THE TARGET USERS

The route must remain consistent in level of difficulty. Caution should be exercised not to overestimate the ability of the target users to evolve and orient themselves. Potentially risky areas (rock falls, ravines) should be avoided except to provide appropriate security facilities.



PAVED ROAD SECTIONS

The main motivation of a hiker is the need to be in close contact with nature. This is why they are most interested in using trails and paths that are in a natural state. Consequently, paved, covered or shaped sections should be reduced as much as possible. 30% unnatural walking area is considered a threshold that should not be exceeded for a long-distance hiking route. For short hikes, this threshold should be close to zero. However, as one of the objectives of a hike is also to discover traditional villages, the portions of pavement included in these small settlements should not be taken into account in an evaluation of this threshold.



ACCESS TO PUBLIC TRANSPORT ROUTES

The route should intersect or be connected episodically to transit stops of public transport, roads, and parking lots as much as possible. These connections facilitate access to the main trailhead, intermediate entrances/exits, and also facilitate the return to the starting point after completing the hike.



ACCOMMODATION

Accommodation facilities are keys to the development of the hiking activity. They allow an increase in the number of walkers and offer the possibility of spending a few days in the area to discover the region. The link between the route and accommodation options (homestays, villages, farms, lodges, hotels, etc.) should always be planned to increase local social and economic benefits. It is even mandatory for long-distance routes.





1.3 - Shapes and positioning of trails and routes



Two main forms of routes are those that start in one place and end in another, and those that start in and return to the same place.

- Linear route from point A to point B
- Looped route that starts and ends at the same location

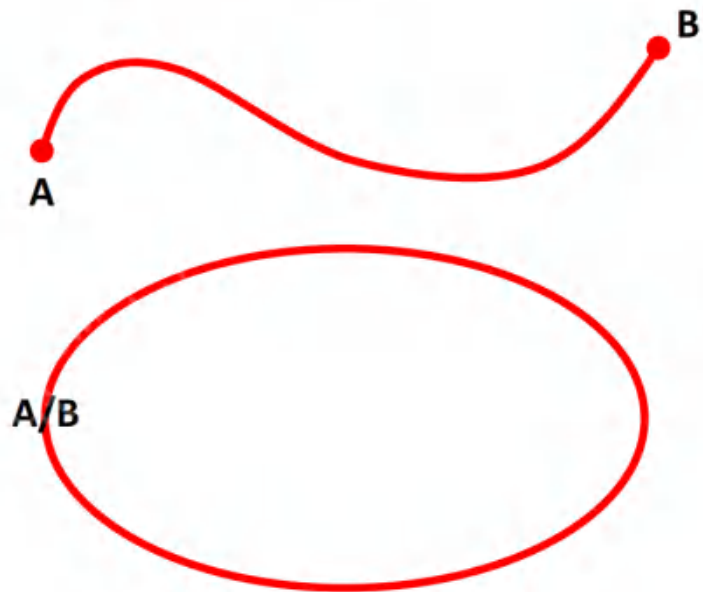

For local trails and more popular trails, we would recommend a looped route over a linear route since it allows the hiker to bypass the need for a round trip on the same path or the organization of a shuttle bus to return to the starting point.



Positioning of tourist trails in the mountains

The trails at the bottom of valleys, crossing mountain passes or ascending to high mountain meadows are, on the whole, existing trails that have always been used by local people for access to their fields, bartering, the passage of livestock, hunting, logging or gathering, religious peregrinations, former raids battles, smuggling, and so on. Today, these trails form the basis of the recreational and tourist trail networks in the mountains and elsewhere, but they do not always offer the best views of the landscape. For this reason, the creation of balcony and ridge trails is sometimes appropriate, with the objective of making the hike more attractive and to better promote the destination.

Positioning of tourist trails in the mountains

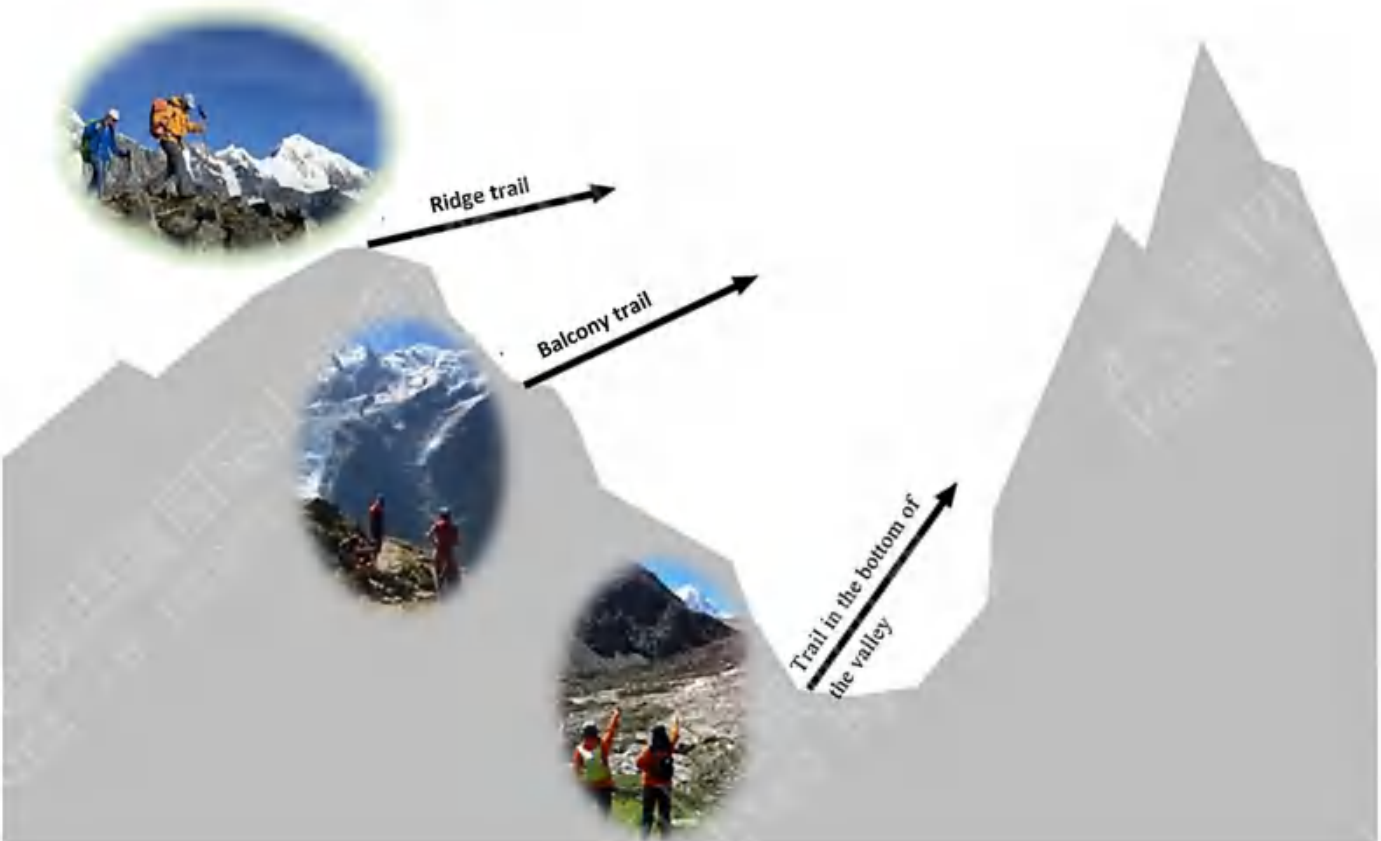

Example of balcony and ridge trails (Chamonix valley to Mont Blanc)

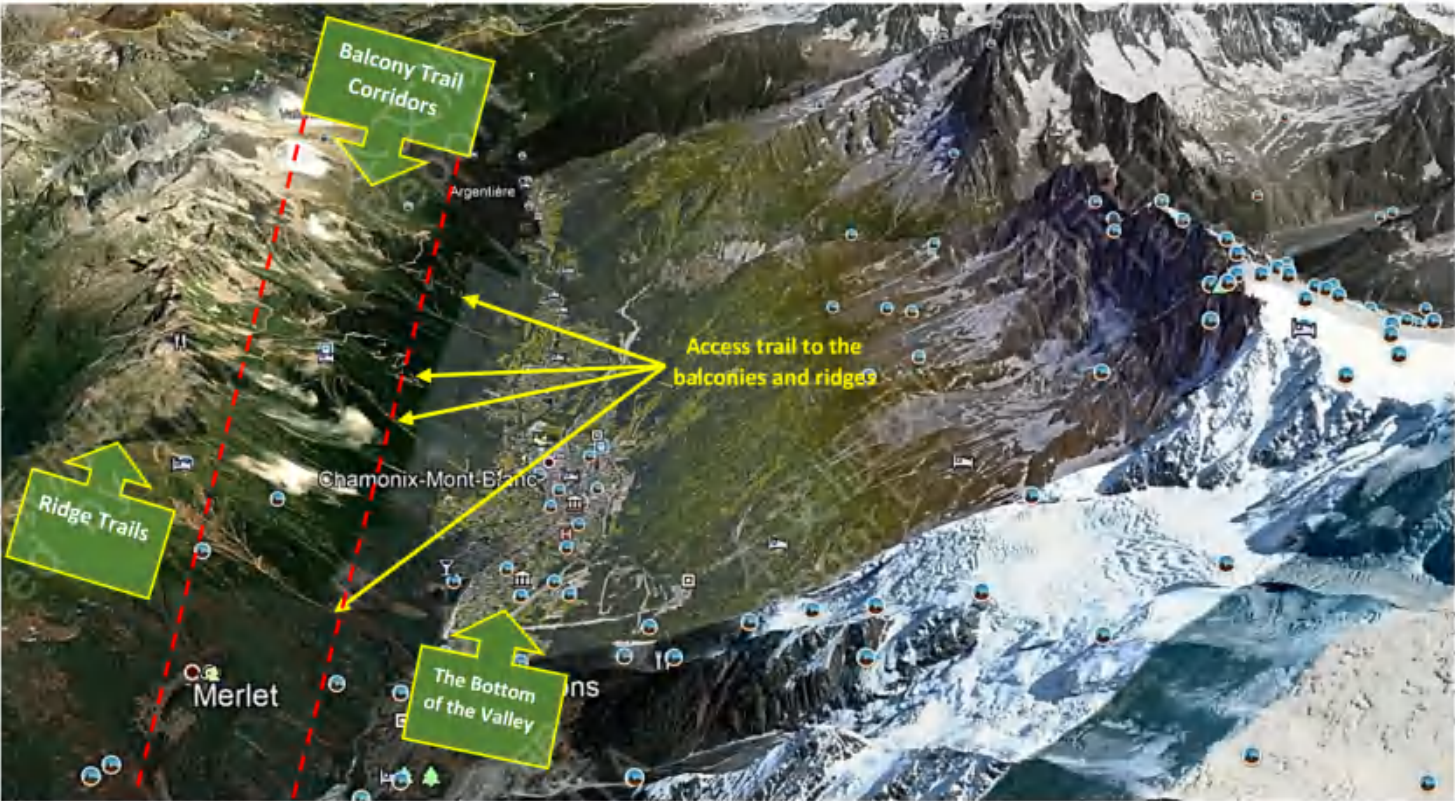



©Serge Koenig: sunset on the Longmenshan massif, Sichuan province (China 2009)



1.4 - Different trails and route systems

BASIC ITINERARY

This simplified sketch represents a loop trail constituting the itinerary and a hiking offer in its own right with:

- Connection to targeted resources: lakes, mountains...
- Connection to a road access...
- A passage leading to an accommodation and/or catering point...
- Etc.



TRAIL ROUTE IN " MARGUERITE " MODE

This simplified sketch shows the principle of the marguerite. When there are several looped routes (refer to: P2 - Chapter 1.3) with a living place or vacation base as the epicenter (village, resort, hotel, lodge, campgrounds, etc.), the system represents a kind of petaled marguerite. Users, tourists and/or local residents have the advantage of starting their trail with the possibility of returning to the starting point without having to retrace the same trail on the way back and without having to organize shuttles to return. These hikes generally last for a half or a whole day.

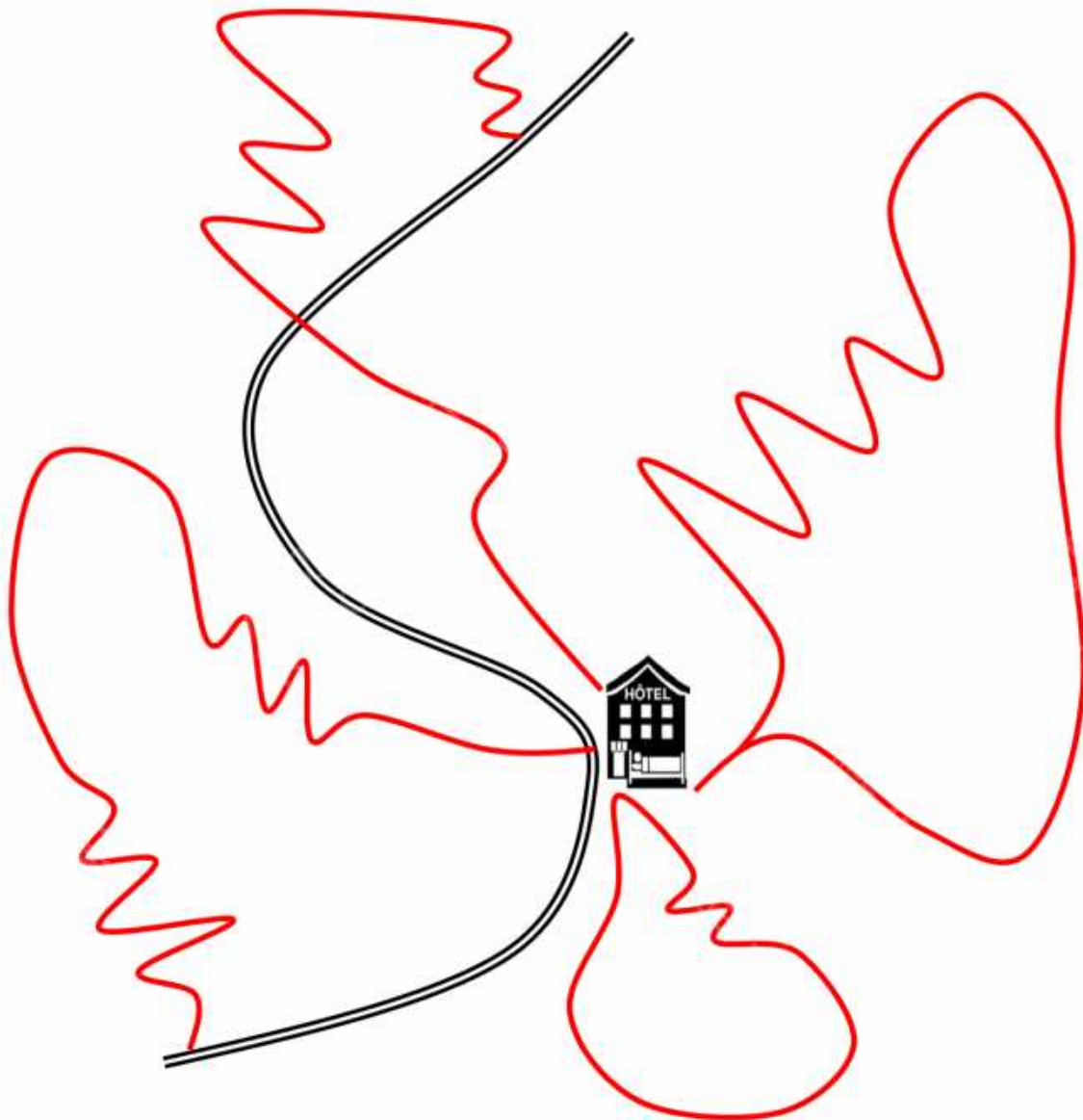

TRAIL ROUTE IN ITINERANT EXCURSION MODE



This simplified sketch shows a multi-day long loop route

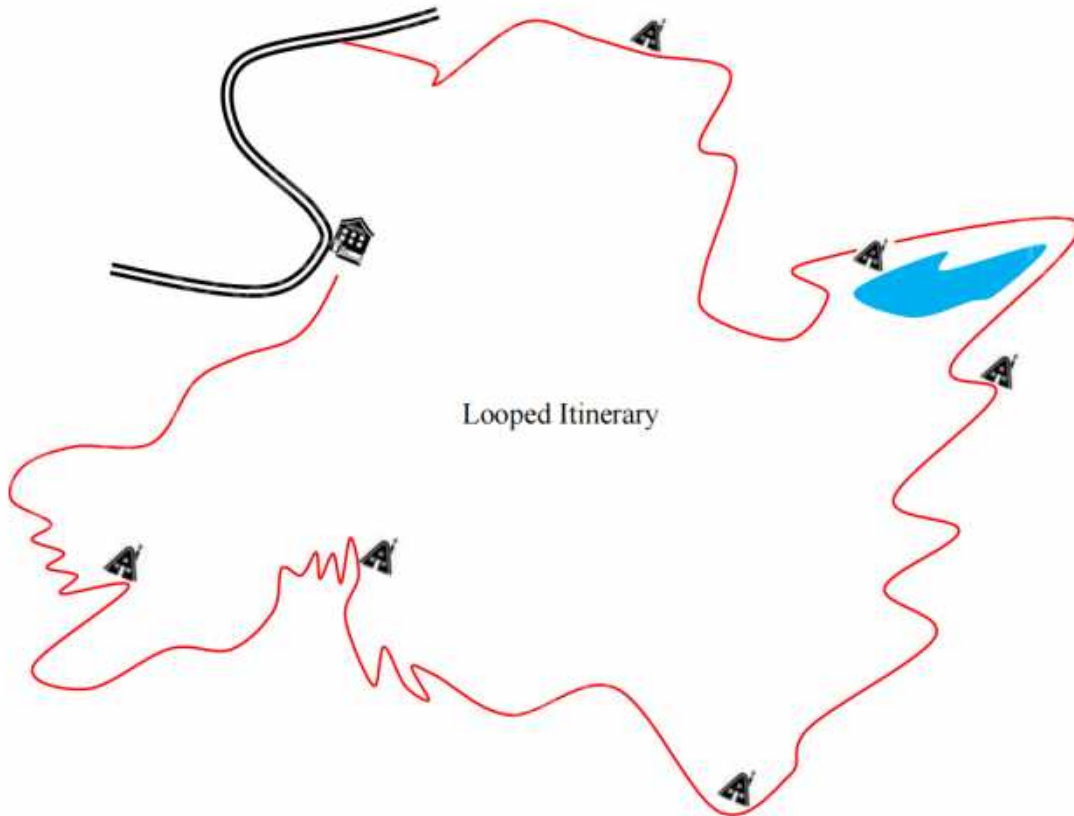

This simplified sketch shows a multi-day long linear route

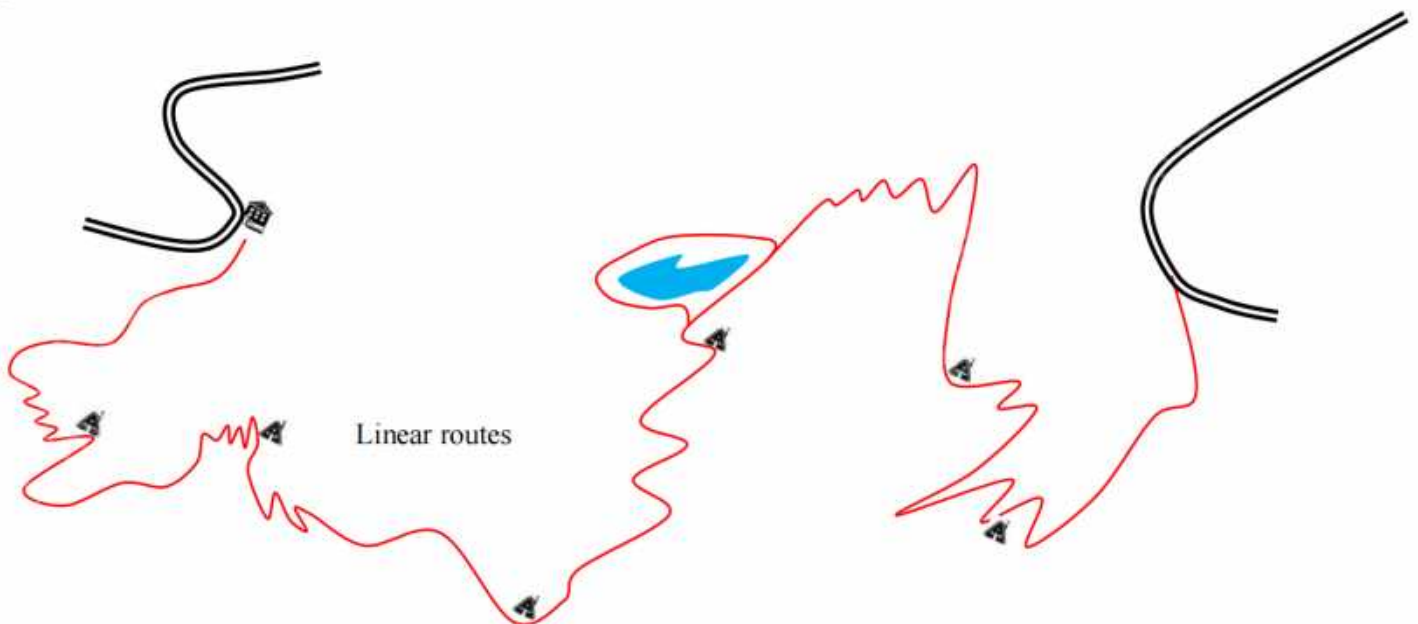

The hike in itinerant excursion mode is a walking trip of several days. The hikers reach a new place of accommodation each evening to sleep in a village, on a farm, in a lodge or in a shelter, on a campsite, in bivouac, etc. This means that hikers carry a certain amount of equipment in their backpacks depending on the itinerary's layout, their preferences and their own expectations. The length of the stages can vary greatly (from 10 km to several dozens of km) depending on the physical abilities of the walkers and their hiking objectives.

Generally, these types of hikes visit the territories by crossing them: they are therefore more linear rather than looping.

If the lodging places are accessible by roads or carriageways, the hike can be organized with the logistical support of a vehicle/driver waiting for them at each stage with the appropriate equipment. This light practice is very popular because it is adapted to hikers who are looking for comfort and the pleasure of not having to carry cumbersome and/or heavy bags, and to trail runners who are looking for performance.

TRAIL ROUTE IN " SEMI-ITINERANT EXCURSION " MODE

This simplified sketch presents the concept of semi-itinerant excursion: here, a vehicle with a driver is necessary (except if an efficient public transport system is available). Hikers change accommodation several times from which they leave on foot or with their vehicle to transfer them to the next point and trail entrance.

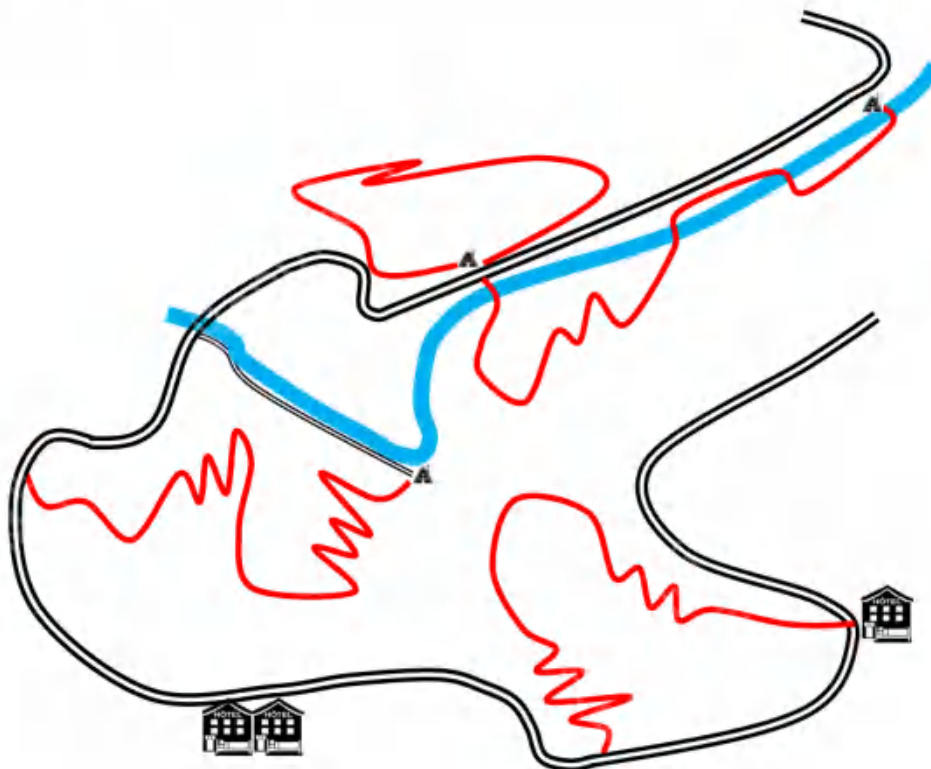

ILLUSTRATION OF A TRAILS AND INTERSECTIONS NETWORK

This simplified sketch represents a concentrated network of adjoining and overlapping itineraries with numerous intersections.



The network should be linked to transportation routes, to nearby villages, to points of interest, and to intermediate exit/entry points. Intermediate exits are also used as back-up routes for hikers in need of assistance: "escape routes" are indeed necessary to improve the safety of the hike.

The network should offer many combinations, with linear trails and loop or "marguerite" trails. It may also have a section of itinerant excursion trail that crosses the territory.

The main route in the center may be wide, comfortable, open and free-flowing, marked as a "go-to" hiking offer for most users. While the other routes (in thin lines) that branch off from it, constitute a network of junctions and may be narrower, steeper and more challenging (refer to: P1 - Chapter 12).



©Serge Koenig: exploring the climbing potential in the Xianju massif, Zhejiang (China 2017)

1.5 - From local trail to regional and national/international network

An interconnection of trails on a regional, national or even international level is the result of a multitude of local networks and a global, coordinated and carefully planned connection project. Long itineraries are long-term projects with a voluntary involvement of the appropriate authorities and stakeholders at various levels (refer to: P1 - Chapter 5).

Generally speaking, lands that are less richly endowed by nature have the advantage of integrating long-distance hiking routes linking regions with greater appeal, in order to benefit from the spin-offs from passing walkers.

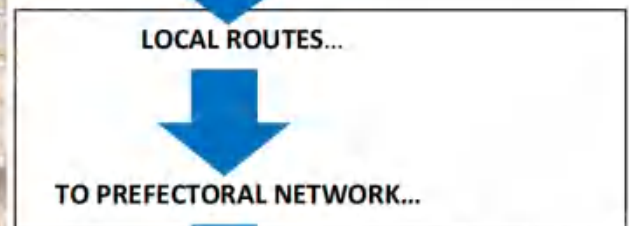

FROM PREFECTORAL NETWORK...

TO PROVINCIAL NETWORK...

TO NATIONAL NETWORK...

Tourisme et Randonnée

Le Plan Départemental des Itinéraires de Promenade et de Randonnée en Haute-Savoie

POPS 2017-2021

Indicateur	2017	2021
Nombre de circuits	120	130
Nombre de circuits de randonnée	100	110
Nombre de circuits de promenade	20	20
Nombre de circuits de randonnée de longue distance	10	10
Nombre de circuits de randonnée de moyenne distance	90	100
Nombre de circuits de promenade de longue distance	10	10
Nombre de circuits de promenade de moyenne distance	10	10

Le Plan Départemental des Itinéraires de Promenade et de Randonnée en Haute-Savoie est un document de planification stratégique qui définit les orientations de développement de la randonnée en Haute-Savoie pour la période 2017-2021.

Ce document est le fruit de la concertation entre les acteurs de la randonnée en Haute-Savoie (Associations de Randonneurs, Clubs de Randonnée, etc.) et les services de l'Etat (DSDS, DSDP, etc.).

Le Plan Départemental des Itinéraires de Promenade et de Randonnée en Haute-Savoie est un document de planification stratégique qui définit les orientations de développement de la randonnée en Haute-Savoie pour la période 2017-2021.

Ce document est le fruit de la concertation entre les acteurs de la randonnée en Haute-Savoie (Associations de Randonneurs, Clubs de Randonnée, etc.) et les services de l'Etat (DSDS, DSDP, etc.).

TO NATIONAL NETWORK

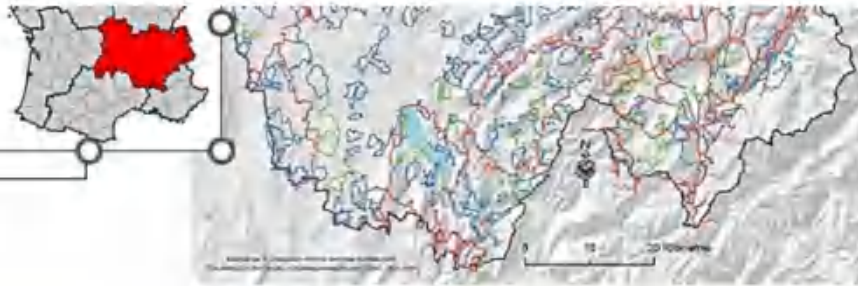

1. Réseau national des Parcs Nationaux
2. Réseau national des Réserves Naturelles
3. Réseau national des Parcs Naturels Régionaux
4. Réseau national des Parcs Naturels de France
5. Réseau national des Parcs Naturels de France



FROM NATIONAL NETWORK...
↓
TO INTERNATIONAL NETWORK...

TO INTERNATIONAL NETWORK...





KEY POINTS TO REMEMBER

What makes an attractive hiking route?

Appropriate services, accommodation, transportation...

Diversity and variation of the environment

Very few paved road sections

Varied and aesthetic trails

Cultural sights

Presence of wildlife

Attractive landscapes

Scenic views and rest areas

Direct proximity to unspoiled nature



©Serge Koenig: sacred lake on the western part of the Gonggashan massif, Kangding, Sichuan Province (China 2017)

TURNING A PROJECT INTO REALITY

2

As with any development project, there is a certain time lag between the preliminary idea, the planning of the project, its implementation and its development.

This chapter will help guide you through this process.

Territory and trail analysis

Policy of the project

Planning and master plan

Detailed trail design

This workflow corresponds to the step-by-step process of creating and developing a trail project. These steps follow one another but may also overlap depending on the requirements of the project.

The project management and organization team will be required to coordinate and conduct simultaneously the administrative/legal procedures and the field/trails studies. Once this procedures and studies have been done, they will contribute to the process of making the project a reality. Its management can be entrusted to an expert trained to master the challenges of the territory, to drive a project, to mediate between different stakeholders and to create and develop tourist packages (refer to: [Part 1 - Chapter 10](#)).

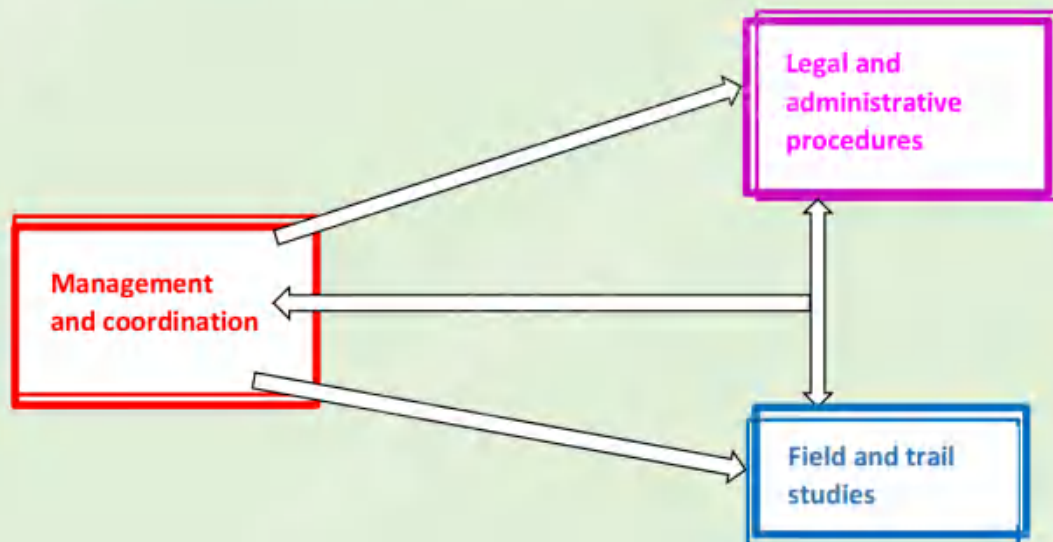

The following chapters correspond to each of the steps listed in the arrows above. These chapters provide guidelines to assist the management team with legal, administrative, and field operations.

Given the wide variety of projects and their diverse requirements, the lists in these guidelines are not exhaustive and are not formally hierarchical. Therefore, it is up to each project leader to extract the information he or she needs and to prioritize them in consideration of the local and national context of the country, as well as the project type.

This document aims to be comprehensive in order to assist in the planning and development of different types of offers, on existing and new trails, and to prepare their management and promotion.

The guidelines provided in this "Part 2" should enable you to start your project while optimizing the chances of success. However, to ensure the proper application of these guidelines, and to benefit from additional knowledge that could be useful, you can consult an experienced operator for each stage of your project.

The work on the field and on the trails in particular are the very core focus of your project. The following is a summary of field work that you and your project management and organization team will be coordinating, among all other efforts.

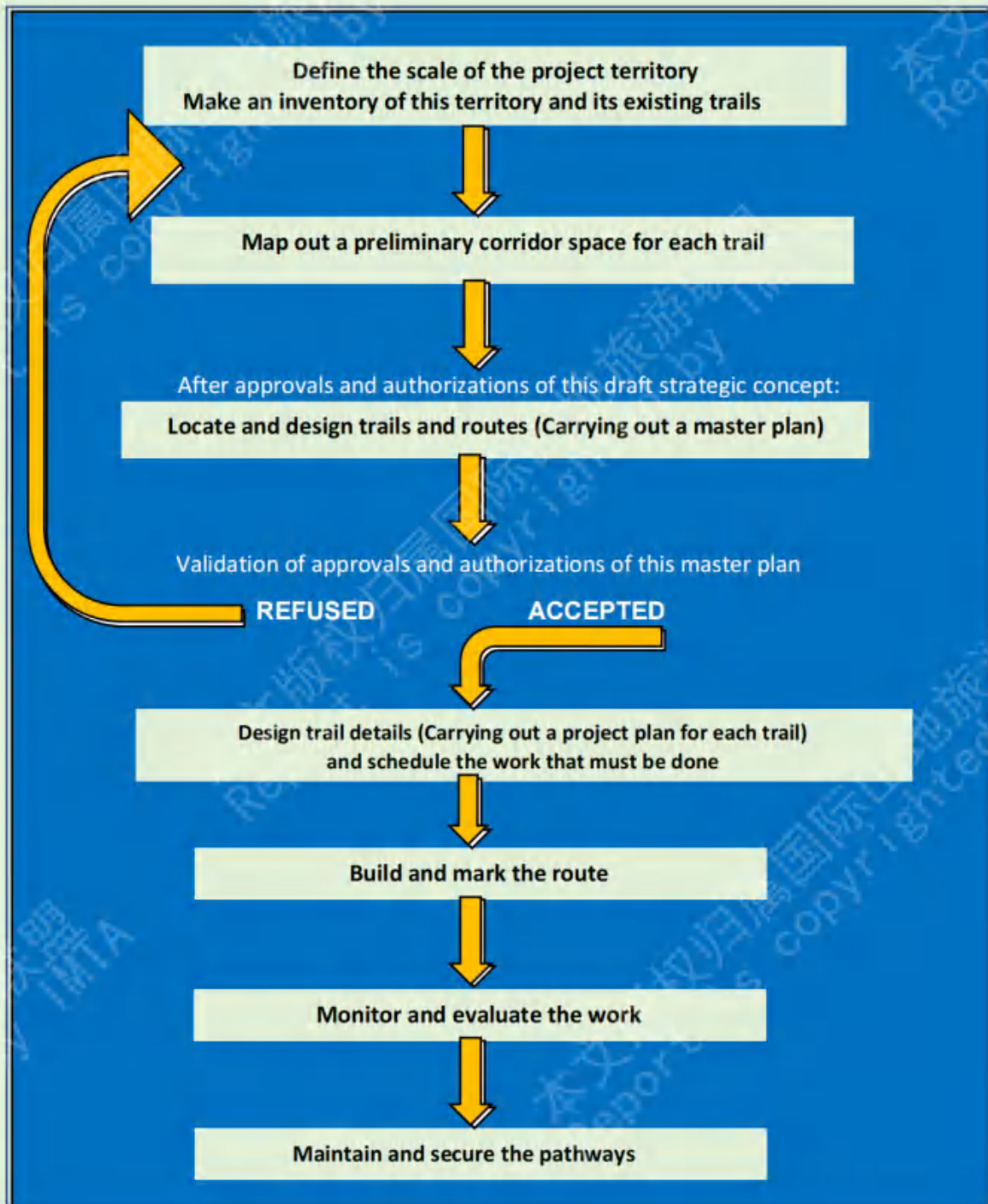

COMPLETE DIAGRAM FROM THE INITIAL IDEA TO THE REALIZATION OF THE PROJECT

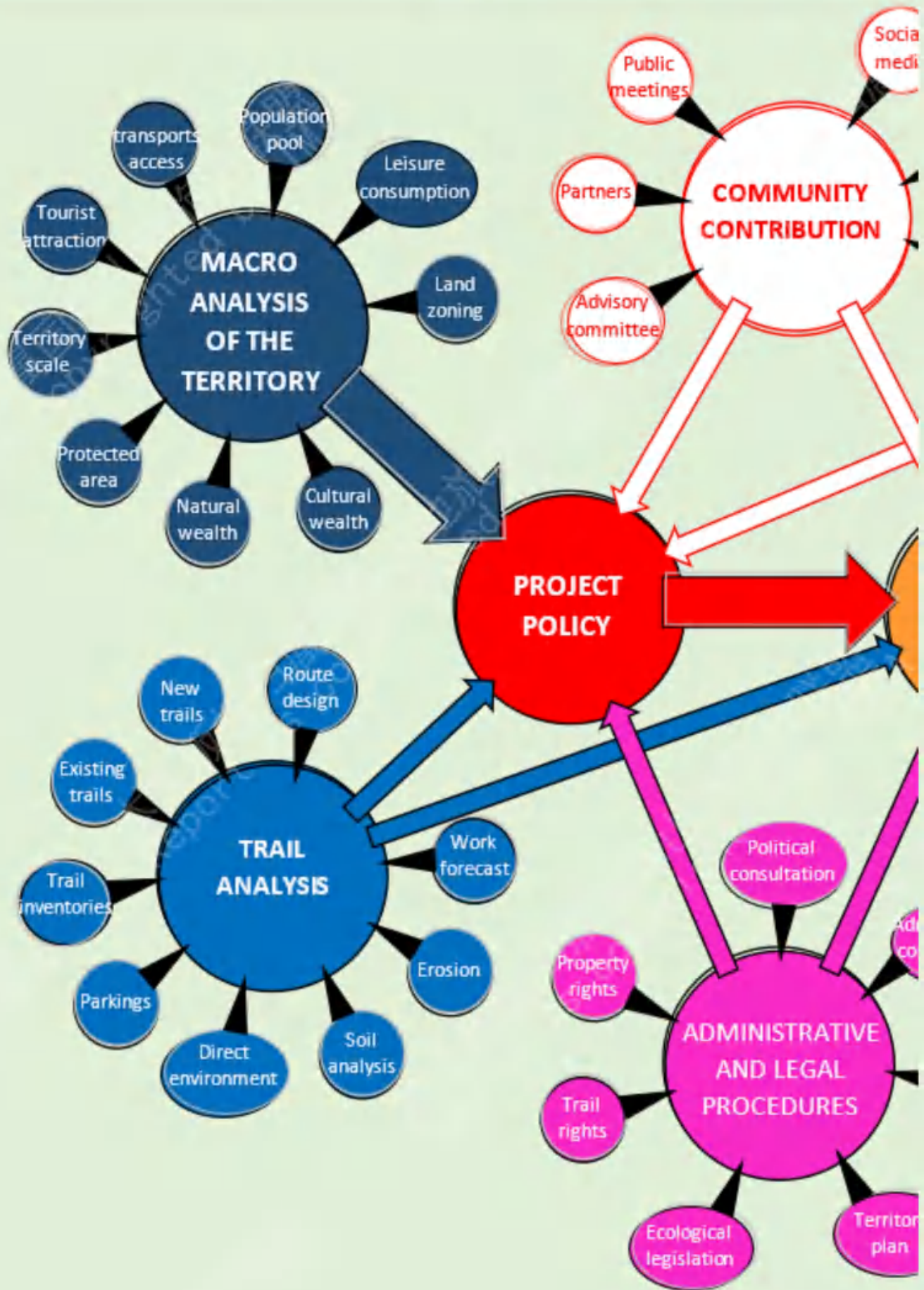



ANALYZE THE TERRITORY AND THE EXISTING TRAILS

3

Investigation and evaluation of various land resources and existing trail networks in the area, with honest assessment of strengths and weaknesses, is a prerequisite to formalize and design your project.

The collection of the possibilities offered by the region and their perspectives will guide the policy definition stage of your project. It will also provide a valuable database for each of the subsequent project steps.

This investigation phase can also, by the many meetings, generate a shared vision of the objectives and strengthen the meaning of your project.

CHAPTER SUMMARY

- 3.1 Purpose of research
- 3.2 Questions for guidance
- 3.3 Terms of reference for the trail field designers

Territory and trail analysis

Policy of the project

Planning and master plan

Detailed trail design

Implementation of work

Marker and signage

Management of trails – promotion of the region through hiking



3.1 - Purpose of research

This mission consists of simultaneously conducting three interdependent actions:



- Research and analysis of "cold data": statistics and thematic on all subjects related to the project's objective;



- Research and analysis of "lukewarm data": topographic, geological and ecoforestry maps, aerial and satellite images, regional plans for the development of public lands, cadastral and land-use plans, urban development plans, local and regional tourism development plans, various existing documents;



- Research and analysis of "warm data":
 - o By consulting and surveying concerned or potentially concerned stakeholders;
 - o By fieldwork to collect information on the heritage elements, but also concerning the accessibility of the sites, existing tourist patterns, etc.

Other than collecting elements directly useful to your project, it is also a matter of developing an understanding of the region, the site, the community, the project surface area, the demographics, the distribution of resources, its potential... and the interactions between these various components. Such study is conducted with a global approach and a multidisciplinary view of the territory, this territory which must be thought of as a system. Your project must be integrated into this system and be part of it.

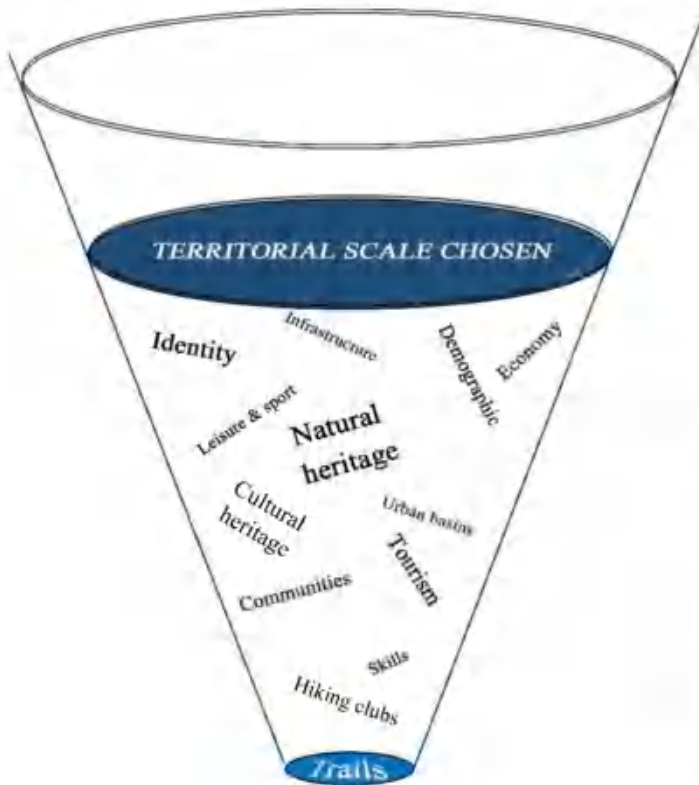

This type of analysis is generally done on a larger area than the one envisaged for the project. The aim is to optimize connectivity between neighboring sites and to seek the best coherence for a policy of the recreational and tourist hiking development in the region.

The approach begins with a macroscopic examination before being progressively refined as the project advances, getting down to the details of each natural area and every trail chosen, before the construction is implemented.

It is essential to know one's natural territory and its biodiversity (fauna, flora, etc.) in order to define the extent of the area to be opened to hikers, the infrastructures to be carried out, the trails traffic to be considered, etc. It is essential to appreciate the complex balance that can be attained so as not to disrupt the natural order of the local environment. The study of the natural environment must be carried out on the fauna, flora and soils in order to determine the vulnerable zones, wetlands and other sensitive sectors to be protected and off limits to visitors. The areas that the trails will run through must be defined with their maximum traffic capacities so as not to degrade them (refer to: P1 - Chapter 12).

This inventory and deciphering work also provides an opportunity to solicit the participation and support of various partners. It will be necessary to consult public and private stakeholders in the sectors of tourism, sports, cultural institutions, transportation, regional planning, environmental protection, natural resources, wildlife and parks, etc. The consultation of several sources, in addition to the wealth of documentation, favors local dynamics and reduces the risk of rejection or misinterpretation of a project. This research phase is in a way a test to gauge or establish dialogue with the people who live on site or nearby. It is also an opportunity to inaugurate a mode of relationship with a population that may have little interest in such project.

It is important to associate local skills with these field missions, which are very useful because of their detailed knowledge of the territory. Where available, hiking clubs and local guides should be contacted or included in the working group. If hiking is not a regular practice, there are still many knowledgeable individuals (farmers, lumberjacks, gatherers, shepherds, etc.) who have extensively walked the paths and trails for needs and professional reasons or for fun.

The inventory of the various data should be digitized and reproduced on maps, plans, diagrams, etc., highlighting the opportunities, especially the particular resources to be developed in your project.



©Serge Koenig: heading towards the sources of the Yangtze River with the Jinsha River between the Sichuan Province and the Tibet autonomous region (China 2014)





3.2 – Questions for guidance

1 MACRO ANALYSIS OF THE TERRITORY ↔ PROJECT POLICY FORMULATION (refer to : P2 - Chapter 3)

- How is the administrative organization of the region divided?
- Who is in charge? Who makes the arrangements? Where is the local authority?
- How is the area irrigated and drained?
- What are the geographical specializations of the areas?
- What are the interactions between sites? How are they organized in practical terms?

- Can you describe the perimeter of the territory? Are there any communities? What are its demographics? What are its allocations of resources? What is its potential?
- What are the territory's identity assets? What are its most remarkable characteristics?
- What is the population pool within a one to four hour transportation radius? How many communities are concerned?
- Have you identified the overall tourism goals and policies? Are there any goals or policies related to nature sports? Are there any related to conservation of sites? On parks? On trails and hiking?
- How much does the local population spend on recreation? What is the region's economic dynamism and standard of living?

- Where are the areas of population concentration?
- What are the major access infrastructures to the region? Where are the desserts?
- What is the plan for major highways, roads, parking lots near natural areas?
- Have you examined the map of the forests? The waterways? Its agricultural areas? The mountains? The countryside? Do you have the map layout?
- Do you have the current land use plan?
- Are there any open areas allocated as a priority for outdoor recreation?

- What is the landscape resource inventory? Cultural resource? Historical resource? Archaeological resource? What are their level of appeal?
- Have you documented and located all of the notable points of interest?
- Have you identified the villages? Are they part of the cultural heritage? Are there any traditional farms?

- What are the biological heritages? Have you conducted their inventories, their locations, their relative conditions? (refer to: P1 - Chapter 12)
- What are the local wildlife and flora?
- Are there any threatened or endangered species?
- Are there areas of undisturbed native habitat?
- Are you aware of any ecological regulations?
- Have you identified the protected areas? Which and what are the classified sites? Are there any wetlands or sensitive areas?

- Are there any successful tourist sites in the area? What are their themes? Where are their facilities?
- Where are the walkable open spaces? What conditions are they in?
- What recreational facilities are available in the area?
- Is there a designated green lane plan?
- Are other trail recreation activities such as mountain biking, horse-riding, etc.? Where are these activities carried out?
- Are there any camping grounds?
- What is the climate like in the region?

- Are there any trails in your area to be diagnosed? Have you located these areas?
- What are the tenure patterns they cross?
- What is the history of these trails?
- Who uses them?
- Is there a need for hiking and trails? Is it for community? Or for tourists?
- Is hiking part of the territory's tourist option? And for neighboring territories?
- Are there any hiking clubs in the local community?

- Have services and occupations related directly or indirectly to trail activities been identified? If yes, what are they?
- Can you describe the "systems" that shape the territory and that will subsequently contribute to your project? Are the sectors directly and indirectly related to your project identified?
- Are there favorable policies for the development of welfare? For example; healthcare?

- Have you found any plans for similar projects?
- Are there any existing trail projects in the region? How are they managed?
- Etc.

2

TRAIL INVENTORY → PROJECT PLANNING PHASE

(refer to: P2 - Chapter 4)

- How extensive is the existing network of paths and trails?
- Have you made an inventory of this network?
- How is the network organized? For example, its connectivity with other trails? With roads? With farms? With touristy points of interest? What are them?
- Do they connect towns and villages? Which ones?
- Do they run along a railroad track? A coastal route? A stream? What is the condition of the riverbanks?
- What direct environment are the trails associated with? Landscapes? Peaks, rivers, canyons etc.? Vegetation cover, wildlife, sensitive and conservation areas? (refer to: P1 - Chapter 12)
- Do you have a relief map? Slope inclination? Altitude?
- Are any of them already part of community plans?
- Have you consulted the local cadastral plans?
- Do you know the status of the routes used? Are they allowed for hikers?

- What are the types of trails? How difficulty are they?
- Do the trails have names?
- Are there any markings?
- What are the terrain conditions and slopes?
- Have you performed digital and centralized modeling of these trail networks to form an overview map of the network and a separate data packet for each trail (one trail/one study)?

- Have you located the most attractive routes? Are they recreational for local people? Or for tourism? What is the landscape like around them?
- What are the priority points of interest (natural, cultural etc.) to be connected by trails? What is their tourism value?
- Do you have sufficient connections to distribute the planned user flows? And to vary the hikes? And to reach points of interest by different paths? And to connect villages?
- Have you located significant parking lots and trailheads? And its intermediate entrances?
- Have you identified the improvements? Is there a need for bridge constructions? Is there a need to increase hiking safety? Where?
- Is it appropriate to create new trails? New junctions? New connections points? Why?
- Etc.

3

IN-DEPTH TRAIL EVALUATION → DETAILED TRAIL DESIGN

(refer to: P2 - Chapter 5)

- Have you a clear vision about your hiking routes network strategy? Or trails intersections networks? (refer to: P2 - Chapter 8)
- Have you mapped the routes? Are they looped? Or linear?
- What is the nature of the soil on the paths? What is its comfort level? What are the widths? The slopes?
- Do you have the trail plans of these layouts? Are the corridors marked with stakes and markers in the field?
- Where are the main entry points located? Intermediate entry points? Are there parking spaces near these entry points? Is there a public transport station?
- What are the destination points of these trails?
- Have you identified the trail sections that should be restored and upgraded? That should have a water draining system? Do they need maintenance? Are there flood zones? What about pruning and clearing work? And the level of soil stabilization? Does it bypass hazardous areas? Does it pass through wetlands? What are the needs of specific developments near sensitive zones? (refer to: P1 - Chapter 12)
- Have you identified the safety improvements needed for the hikes? Where are they? With what type of facilities?
- Need your project any infrastructure to cross water obstacles or ravines? Where are they? What are the sizes? What is the condition of the river or ravine banks?
- Does your work plan comply with all regulations?
- Are there any natural materials available on the site and that can be used for the trail construction needs? Wood from the forest? Or stone, or gravel from the ground?
- Did you report the precise inventory on maps and reports, the sum of the study information with descriptions of the work planned?
- What types of tools, construction machinery, trail equipment/materials, etc. will be needed for the building work?
- Have you identified the potential for drivable access by vehicles to the work areas?
- Are you ready for the installation of markings and signage? Does your plan follow the same signage guidelines throughout your trail network?
- Etc.

EXAMPLES OF INFORMATIVE NOTES TO BE PROVIDED IN THE TRAIL ANALYSIS



(Source: Camino El Chorro - Sierra de Huma, Spain)

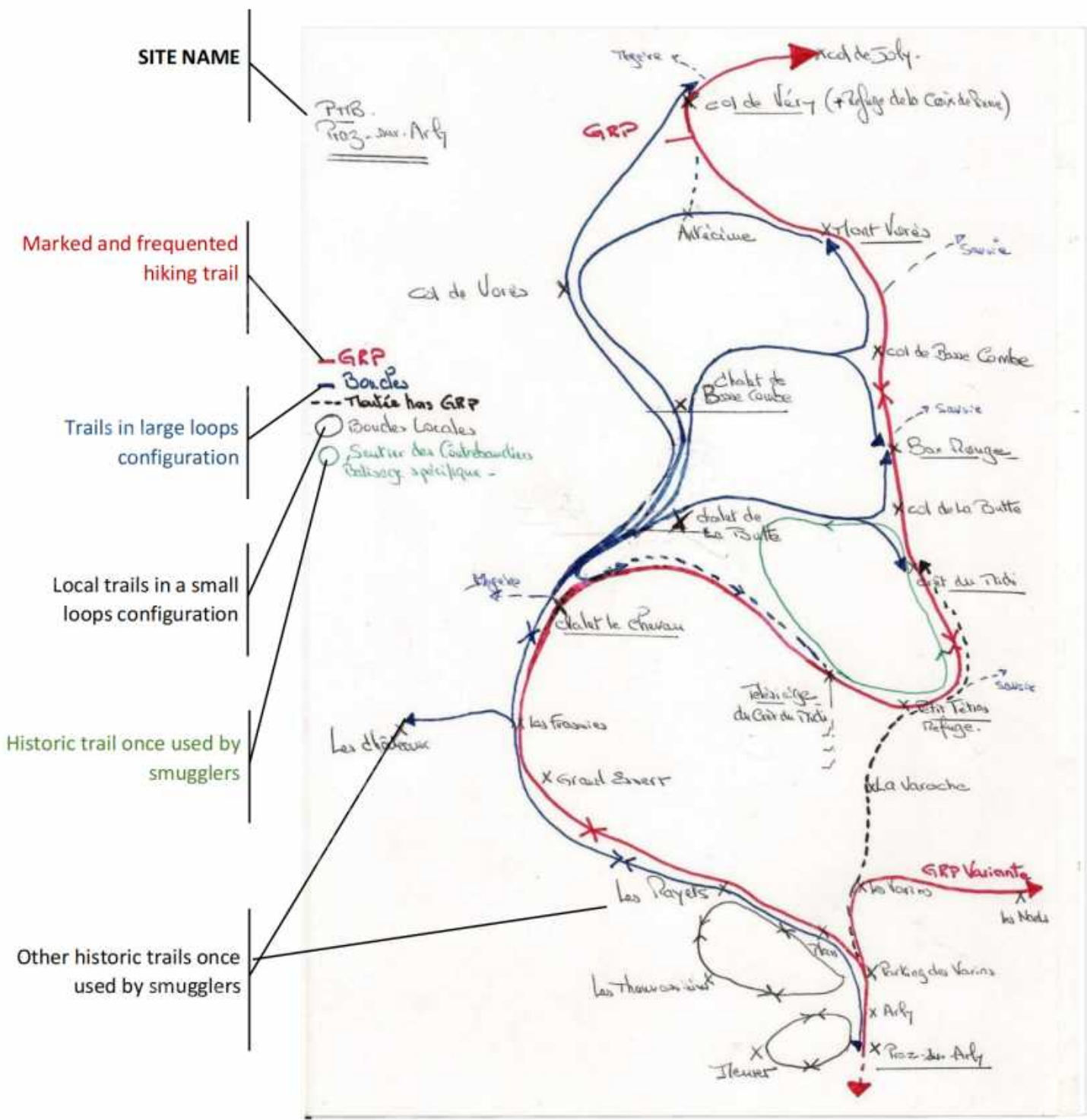

(Source: sketch of the trail network in Praz-sur-Arly in France - Eric Thiolère, Trail Advisor Haute Savoie)



©Serge Koenig: the inventory of resources for "Tea Trails" by the Alps-Sichuan cooperation team (China 2012)



©Serge Koenig: the main equipment of the Alps-Sichuan scouting team on the "tea trails" (China 2012)

3.3 – Terms of reference for the trail field designers

The designers team on the spot will consist of:

- Hiking enthusiasts, whether professionals or passionate amateurs, who are familiar with the data collection methods used and the use of wireless devices. They must know perfectly the elements of your project;
- People who know the area well, such as hikers, guides, lumberjacks, shepherds, farmers, etc.

These individuals are equipped with GPSs, cameras, watches, distance indicators and data sheets to be filled out during the scouting work in the field.

Example of information table to complete:

POINT	GPS READING	TITLE	KM TIME	DESCRIPTION OF LOCATION	PHOTOS OF THE LOCATION AND THE SURROUNDING ENVIRONMENT

- Point: reference point numbering where the team is;
- GPS survey: longitude and latitude of the location mentioned;
- Title: name of the site;
- km: separation distance from the trailhead (starting point);
- Time: walking time from the starting point;
- Description of location: including all relevant information;
- Photo: photograph numbering of the concerned place with an explanation of the subject of the photo.

This field study for each trail identified should be composed of completed information sheets, numbered photos, and the GPS route on 2D and 3D maps with the photos indications (the photos and the points where they was taken) identified on the records.

TABLE: Example of a short trail survey in a valley in Huangshan (China)

POINT	GPS READING	TITLE	KM TIME	DESCRIPTION OF LOCATION	PHOTOS OF THE LOCATION AND THE SURROUNDING ENVIRONMENT
1	30°11'46.86"N 118°13'59.87"E Alt : 232 m	Historic houses	0.5 km 10 min	10 min after the start of the trail, the path crosses an old property on an agricultural site.	
2	30°11'08.25"N 118°13'55.84"E Alt : 313 m	Rock sloped pathways	1.3 km 25 min	The valley narrows and the trail winds upwards on slabs of rocks along the river with green basins and waterfalls.	 
3	30°10'56.01"N 118°13'42.92"E Alt : 370 m	Intersection of trails	1.9 km 35 min	Intersection between the trail that continues along the valley floor along the river (left bank) and a staircase trail that climbs up the right side of the river to return by a loop trail to the hike start through the forest.	 
4	30°10'24.16"N 118°13'49.32"E Alt : 503 m	Passage through forested left bank	3 km 1h15min	The trail passes on the left bank of the trail that becomes progressively steeper and enters a forest environment.	 
5	30°09'55.33"N 118°13'31.97"E Alt : 660 m	Footbridge	4.2 km 1h50min	The trail crosses a rough footbridge over a secondary stream bed and continues on the left bank of the main river before reaching the valley floor.	
6	30°09'47.61"N 118°12'40.91"E Alt : 904 m	The Blue Lake	5.8 km 2h35min	A remarkable blue/greenish lake of the river, with the trail leading back across to the opposite right side of the river.	  
7	30°09'36.37"N 118°12'15.62"E Alt : 1,067 m	Climb on the right bank	6.6 km 3h10min	The narrow path climbs the steep and rocky slope in a forest environment gradually revealing the landscape of Huangshan.	 
8	30°09'28.07"N 118°11'56.94"E Alt : 1,218 m	Crested trail	7.2 km 3h45min	The trail climbs the steep hillside to the summit and follows the narrow ridge between two beautiful valleys.	   
9	30°09'23.28"N 118°11'35.90"E Alt : 1,299 m		7.8 km 4h15min	Rugged trail that leads to a scenic lookout. Return to start point of the hike by the same path (2h30 to walk back).	  

(The indicated times are average hiking time for adult medium level hikers)

GPS location plots with 3D map markers





KEY POINTS TO REMEMBER

Warm data: field studies and local actors consultations

Lukewarm data: maps, plans...

Cold data: statistics...

A professional and experienced team

What makes

an effective territory and trail analysis?

Identification at the right scale

The participation of local skills and local actors

A study of the natural environment: fauna, flora, soil

Location of wetlands and sensitive areas



DEFINE YOUR TRAIL PROJECT POLICY

4

The work of defining your trail project policy will be done simultaneously with the field diagnosis stage (previous chapter). The field diagnostic will help in the political decision making process of the project, and the political choices will guide the field analysis.

This step is essential to support the major directions that will constitute the backbone of the project and of all the following steps.

Hence, this is an important stage that should be given close attention.

CHAPTER SUMMARY

- 4.1 Questions for guidance
- 4.2 Inventory analysis
- 4.3 What is the project type? What are the objectives?
- 4.4 Define the scale of the project
- 4.5 Who are the target user groups? What kind of hiking activity?
- 4.6 What are the potential partners for this project?







4.1 – Questions for guidance

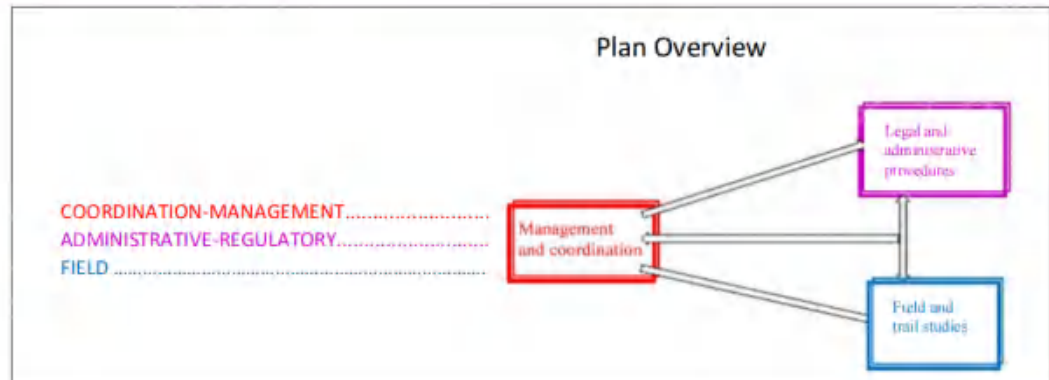

Questions concerning field and trail studies

Is the macro analysis of the territory done?

- Did you collect all the cold, lukewarm and warm data? Is there any data missing? What are they?

Questions concerning management and organizational approaches

Have you:

- Identified the project model in terms of objective(s) and operations?
- Defined the territory scale of the project?
- Involved the relevant authorities at the relevant level?
- Made your choice between the supply or demand strategy?
- Assessed the supply and demand for hiking products in the region (preliminary marketing analysis)?
- Identified and reviewed the target market and intended user segments?
- Identified the category and general characteristics of the trails being sought?
- Defined the desired trail experience?
- Identified the project stakeholders and communities you will be working with?
- Consulted and involved these stakeholders in discussion?
- Created a reference or steering group with these stakeholders?



4.2 - Inventory analysis

The analysis of the inventories (inventory of the territory's resources and trail study in "Chapter 3 of P2") will allow you to better identify the real potential of the project's host territory in order to make appropriate decisions.

An honest and uncompromising estimation of the area's resources must be taken into consideration: an over- or underestimation will lead to inappropriate decisions that may result in project failure.

- How attractive is the area? How attractive is it from a local perspective? A regional perspective? A national or international perspective? (refer to: P1 - Chapter 8)
 - On what kind of space do you want to value the panel of resources identified? Why? What is the legal status of the land in this area?
 - Can you imagine the development of this heritage as a whole? Or rather make choices by developing just some resources and omitting some others?
 - Does these resources fit your initial plan for trail experiences?
 - Are there enough existing trails to be the basis for your project? In what condition are they in and what is the level of work and restauration required to bring them up to standard?
 - Do the existing trails make the best enhancement of the landscape, architectural, and natural heritage? Or should new trails be built?
 - What is the practice level of recreational and sport hiking in local communities? What about among tourist groups visiting the region by hiking?
-
- Are there already other existing trails offered in the region? What type of offers are they?
 - Is your project and add-on to existing offers or does it complement them?
 - How far from major population centers is the area envisaged for your project? And is it close to frequented tourist sites? What is the pool of potential users? In what travel distance?

What is the acceptable travel distance?

Overall, people are willing to drive between two and four hours maximum (round trip) for an interesting hiking day trip, and between six and ten hours (round trip) for a weekend trip.

However, this ratio of travel versus activity time varies according to the level of interest and passion of the users and according to the habits of the regions and countries.

A local hiking destination should reasonably be located within a two-hour travel time of an urban center or population concentrated pool. A tourist hiking destination can be located within three to four hours of travel time (to attract the short stays necessary for economic survival) or further if the site is highly touristy with many other offerings.



©Serge Koenig : Resource inventory for "tea trails" by Alpes-Sichuan in Qionglai (China 2012)



©Serge Koenig : work on the design of the "tea trails" offer by Alpes-Sichuan in Chengdu (China 2012)

4.3 - What is the project type? What are the objectives?

What will your trails be used for? What is the added value of your project? What are the benefits sought/expected? For whom?

What is your desired project model in terms of purpose and operation?:



- Developing in priority a community trail that is open to all and provides benefits to the population:
 - o With trails designed as a public infrastructure for fun, sports, recreation... a privileged destination for local outdoor activities, environmental awareness, heritage enhancement;
 - o By building a community asset with the help of (or by) public authorities or state agencies, and the participation of the community itself.



- Developing a project in priority with commercial purpose (paid entrances and concentrated services) with profits for an individual or an operating company (private or mixed):
 - o With the construction, for example, of a recreational and tourist park property;
 - o With trails in a privatized open space, themed trails, built from scratch, with heavy or light development, etc.



- Developing a community and tourism project at the same time that will enhance the overall tourism offer of the region and strengthen its revenues (such as a long-distance trail, refer to: P2 - Chapter 1 and P1 – Chapter 5):
 - o With free access for the benefit of quality of life and health in the region, and an attractive tourist attraction;
 - o With commercial tourist services and spillover and indirect economic benefits (the tourists who hike spend money to sleep, to eat, to buy souvenirs, gear, etc.).

Knowing how to bring the right arguments...

One of the first questions that concerns governments, land managers, and potential stakeholders is the question of "Does your trail project meet the users' expectations?"

Without a strong argument that demonstrate that your trail project meets a need and that your trails will be used, it is unlikely that your project will be supported and funded.

Also, have a deep knowledge of the existing hiking and trail offerings in the region, examining their characteristics, management, and use, will be very helpful in determining the relevance of your project. Your project could be an additional similar trail offer to spread out the flow of the users, for example, or a complementary different trail offer to attract other user segments.

Clearly identify the motivations behind the project will allow you to better clarify its objectives. Is its purpose:

- To create a new activity in an economically underdeveloped region?
 - Or to accompany some diversification in traditional economic activities (agriculture, logging, fishing)?
 - Or to revive a declining traditional tourism and diversify the available tourist offer?
 - Or to economically develop a pre-existing hiking activity?
 - Or to manage the existing flow of hikers?
 - Or engage in a sustainable development approach by promoting a form of green tourism?
 - Or perpetuate a local heritage by giving it a tourist focus?
-
- What is the place of the project in the overall strategy of local development? Is it part of the global planning?
 - What real interest does the project have to offer?
 - What resources are available for this project?
 - Etc.

Building a project means answering a plethora of questions...

Unless it is a totally independent project, privately financed, on private land free of all architectural, neighborhood and environmental constraints, relevant political decision-makers must be involved at this stage. Depending on the assets of the territory, its resources, the expectations of the community, the existing master plans for development and global planning of the territory, the regulations in force, etc., the decision-makers may or may not choose to support and authorize such an initiative and/or project theme. Their decisions take into account legislative considerations, economic and human considerations, but also the coherence between the size of the project envisaged and the potentially available means.

Be consistent with a global policy for better success...

Integrating a trail project into an existing development and operations program bring more chance of success. Proper coordination between existing and planned activities will be essential.



©Serge Koenig: Kurtai Canyon leading to Kalajun Lake in the Ili Prefecture of Xinjiang (China 2017)



©Serge Koenig: exploration of a project in the Kazakh Prefecture of Ili in Xinjiang (China 2016)

4.4 - Define the scale of the project

Before engaging in the project, ideally before the macro analysis of the field, it is necessary to know the size of the territory on which the project will be implemented: local, regional, or national? At the size of a site? Of a massif? And so on...

A recreational and/or tourism hiking development project in general requires a certain territorial scope.

The first criterion to be considered is the coherence of the territory, which, beyond administrative limits, must constitute a sufficiently legible entity for tourists and potential users. This scale can be at the level of a region, a mountain range, a nature reserve, a prefecture or even a municipality (the municipal level may be sufficient in China, for example, given the size of the country, whereas it is generally unsuitable and too small for European countries).

The size of the territory envisaged, including the richness of its heritage, the diversity of its resources, the pool of potential trail users, etc., will help calibrate the ambition of your project from the start.

When several neighboring communities have established networks of hiking trails on their own land, some of these routes can then be interconnected to offer users the option of trails on a larger scale: intermunicipal, cantonal, prefectural, provincial/regional, or even national/international (refer to: P1 - Chapter 5)

Different local projects can ideally be planned simultaneously and in a coordinated manner as part of a strategy to develop this trail offer on a larger scale. Such a strategy would create a new and much more attractive cross-regional tourism area for hikers of local, regional, national and international tourism, with win-win interests for all the actors and regions involved.

"Long-distance" and "very-long-distance" hikes (refer to: P1 - Chapter 9) do not necessarily reach the same audience as local hikes. However, the local sections of these long hikes share the same users as the local trail systems. These long-distance hikes are a real added value to the existing local offer and an asset for the promotion of the regions they cross. The areas of secondary interest are thus associated with an overall project and drawn up by the region's "must visits" with which they are connected by the hikes.

TABLE: shows some advantages and disadvantages of the different levels of scale

(source: Australia)

Scale level	Advantages	Disadvantages
Work on a small scale (commune, inter-communal)	<ul style="list-style-type: none"> - Better knowledge of local needs and issues; - More responsive and action-oriented; - More affordable in every perspective; - And so forth. 	<ul style="list-style-type: none"> - Smaller vision; - Risk of inconsistency on a larger scale; - Local trails more complicate to interconnect if they are not planned on a large scale; - And so forth.
Work on a medium scale (regional, departmental)	<ul style="list-style-type: none"> - Most appropriate scale (especially to get a clearer idea about the project) for planning a trail network even at the local level; - Better alignment with projects of neighbouring municipalities; - Allows for the reconciliation of local needs with regional and national challenges; - Allows the project to be part of a regional development and tourism plan; - And so forth. 	<ul style="list-style-type: none"> - A need to make compromises between the project level and those with a higher level; - Must respect the guidelines of the regional plan ; - And so forth.
Work on a large scale (national)	<ul style="list-style-type: none"> - Global vision for the development of the territory - Allows greater flexibility at the local level - Fosters creativity and innovation in line with each local area - And so forth. 	<ul style="list-style-type: none"> - Weak coverage of needs accommodated - Requires monitoring and steering advanced and sometimes complicated - Incurs high costs of coordination - Risk of poor responsiveness - And so forth.





©Armand Ducornet: hiking on a trail in Bad Urach (Germany 2019)



©OT Chamonix, The alps (France)

4.5 - Who are the target users? What kind of hiking activity?

Being clear on both the target user segments and the type of your trail offering is key to getting your project off to a good start. Defining your supply based on the demand, rather than defining the demand based on your supply, is generally the best approach, as one can create the other and vice versa. However, the particularities of each situation must be taken into account when defining the nature of the offer you wish to develop.

SUPPLY ON DEMAND OR DEMAND ON SUPPLY MARKETING?



Do you want to develop something because the hiking potential is remarkable?

- Conduct a comprehensive inventory of the project's offerings;
- Target user segments that may be interested in this offering;
- Evaluate the feasibility, identify possible adaptations of the offer according to user profiles;
- Implement a marketing strategy for the hike.



Do you want to develop a hike because users exist or because there is a large potential of hike users?

- Target the segment(s) of the target audience with a particular focus on their profiles and expectations;
- Inventorize the natural resources available for an offer and all the elements useful for its design. Are they operable? Adaptable? Should they be created? Or possibly imported in?
- Implement a marketing strategy for the hike.



Do you want to develop an offering to generate community economy or a social profit when there is a lack of both attractive resources and user potential?

- Conduct a general analysis: the natural and human potential, the "tools" and the financial means at your disposal;
- Based on this analysis, choose the type of offer that is consistent with a target group of users;
- Implement a marketing strategy for the hike.

SEGMENT AND SELECT TARGET USERS

You need to carefully consider the potential user segment(s) and make target choices taking into consideration their expectations, your purpose, the attractiveness of the area, and the trail experience you plan to offer. It is up to you to find the best fit between these factors.

The reflection on the target users will then allow the construction of a relevant hike adapted to their expectations: which trail design (length, difficulty, location...)? What level and types of services should be offered? And so on...

While trails can often be designed to accommodate a wide range of user segments with different interests and needs, they can also be designed for a specific segment. The easier the trail is with a low elevation gain, the more accessible it will be to any audience. The more difficult the trail, the narrower the target group (e.g., for experienced hikers only). However, a particular trail, less frequented and more "elitist", can potentially become emblematic and strongly contribute to the branding of your offer and the image of the region. Finding the right focus for each trail is crucial.

A brief reminder: the trail experience expected by different hiker profiles (refer to: P1 - Chapter 9)

Walking, the focus of this study, includes all forms of pedestrian recreation and tourism, from a stroll in a local green park to strenuous hikes through adventurous, hostile territories. The walking experience can also be combined with other enriching and complementary activities (refer to: P1 - Chapter 8), involve accompanying animals and pack animals, be done at night or include stops in huts or camps, etc. Walkers may use trails in urban and peri-urban areas, rural areas, coastlines, mountains or other wild, natural environments.

- Urban walkers use natural or paved trails in suburban areas, green spaces, public gardens, canal banks and railway tracks... They use trails for fitness, social reasons and for their daily lives.
- Rural walkers are more likely to seek out nature trail experiences related to agro-tourism, ecotourism, exchange with local communities, resourcing, reconnecting with nature and animals, overnight stays on a farm...
- Hikers in mountain areas or other wilderness areas seek natural trail experiences with great scenery, including challenging, more athletic and remote trails. These hikers can be self-sufficient in terms of logistics (carrying their own gear, bivouac equipment, adequate food) on demanding treks.
- Trail-runners and fast hikers are motivated by the challenge, the fact of pushing one's limits, with a determined mindset. They use a variety of trails ranging from paved urban trails to steep, more challenging mountain trails (e.g. trail running).

Other forms of outdoor excursion not covered in this "guide": bicycle touring, mountain biking, horseback riding (or even motorized outdoor tours, which is not recommended in the wilderness) can also be practiced on dedicated or shared trails.



If the project has a tourism focus, getting help from a marketing professional at this early stage would be appropriate.

In the world and jargon of marketing, the hiker becomes the "customer" or "client", reducing the project's vocation mainly to its economic profitability. In this study, we prefer to call the hiker a "user", whether he or she is a local hiker or a tourist, considering social and societal profitability on the same level as economic profitability: it is a notion that is inseparable from the practice of hiking in the noble sense of the term and concept.

A marketing expert will be able to effectively accompany your project throughout its development:

- In this initial phase:
 - o to target user segments;
 - o to conduct a preliminary survey with corresponding range of users;
 - o to define the marketing criteria that will guide the design of the offer and the trails (or vice versa).
- In a second phase: to attract more visitors with tailored communication campaigns;
- In the longer term: to evaluate the levels of frequentation and satisfaction, to anticipate the future evolution of your offer according to future trends (this effort of projection is useful to plan the project with more efficiency)

An expert can also gain valuable insight into:

- Your direct competitors (i.e. similar projects in the region) and their development and operating strategies;
- Existing surveys and studies on the same subject conducted in destinations elsewhere in the world (the surveys on the subject are varied and numerous).

TABLE : A brief analysis of two different targets that you will have to consider.

This is just one example of the elements that need to be considered when thinking about user segmentation and the targeting process.

Profile	Advantages	Disadvantages	Benefits	What attracts them
Core users, (locals living in the area and that are easy to reach)	- Low investment in terms of communication; - Easy to engage; - Few related services; - And so forth.	- Generates little spendings; - Remains local; - And so forth.	- In societal terms or socially; - Health and fitness; - Cost effective public health service (helps reduce obesity and other potential diseases including cardiovascular diseases); - And so forth.	- Hiking daily ; - Physical activities for good health near home; - Soft mobility; - And so forth.
Users to conquer (those who live elsewhere and are to be attracted)	- Bigger spenders; - Must use infrastructure with tourist facilities including accommodation and restaurants; - Consume direct services and indirect services relating to trail use; - And so forth.	- Investment in multiple and related services and anywhere in between; - High quality levels, international standard - Investment in promotion and marketing which can potentially be expensive; - And so forth.	- Direct and indirect economic benefits; - Creation of jobs; - And so forth.	- The quality of the hike; - The services provided during the hike; - Making new discoveries; - Relaxation and well-being; - And so forth.

Two other user groups that could be considered:



The "one-timers", who does not have a very high requirements. This target choice is possible depending on the volume of the tourist pool and the level of natural appeal of the site. Advertising that is sometimes very much "embellished" from the reality of the offer has shown that it can contribute to this attractiveness. The objective is financially-focused. But the target groups are traditional tourism far removed from hiking and the concept may not be sustainable for long time.



The user that you want to satisfy and retain are the ones that perhaps come back on vacation with their family and friends or extend the duration of stay to enjoy the activities and nature.

This approach requires a high level of user satisfaction (quality of the trails, quality of the overall trail experience, quality of services, sustainability, accessibility, alignment with visitor aspirations, etc.). If these users are enchanted by the leisure activities available, they will come back with a willingness to stay and spend. This strategy has an additional advantage in terms of environmental protection: vacationers who regularly visit a place that they have learned to love and preserve will respect it more than "one-time users", i.e., someone who is just passing through.

Word of mouth

The best form of advertising, because the most sincere, the most effective, and also free of charge, is the "word of mouth". The word of mouth is the spontaneous feedback that the trail user shares with their friends, colleagues, or via social networks when he/she comes back from a hike. If he/she is satisfied or very satisfied, people will know this. Similarly, if they are dissatisfied, they will also let others know.

Users, locals, or tourists who come back delighted with their hiking experience are the best ambassadors of your hike and your tourist offer.



©Serge Koenig: Yangshuo-Guilin, outdoor sports paradise, Guangxi province (China 2017)



©Serge Koenig: business card exchange during a forum on nature sports in Chengdu (China 2012)



©Serge Koenig Collection: conclusion of the training partnership for mountain professions between the National Ski and Mountaineering School (ENSA) of Chamonix and the Lhasa Mountain School founded by Nima Tsering (China 2005)

4.6 - What are the potential partners for this project?

At this point, it is important to identify and involve stakeholders directly concerned by the project and to involve them in a reference group or steering committee to help manage and coordinate the planning process. Members will be drawn from:

- the community(ies) through which the trail or trail system passes. The community brings knowledge of the terrain, proximity of users, accurate appreciation of local development needs, and the ability to mobilize more easily human and financial resources.
- local or higher-level government (such as provincial). In particular, these government officials issue permits and provide technical expertise and financial resources.

This reference group could include land managers and land owners, user groups from hiking clubs, local and regional tourism operators, representatives of companies and potential investors, service providers such as accommodation providers, guides, etc., and the representatives of the communities and public authorities mentioned above. While broad representation will require greater communication efforts, it will result in more sophisticated and effective planning, greater local community ownership of the final project, and more support. Some stakeholders may become long-term partners of your projects if they are built on an equitable, win-win basis.

This group will be able to participate in the choice and decision making process mentioned above. It also allows you to work with and test the adequacy of your project with the aspirations and needs of future users.

It can be very useful in resolving questions related to the landowners, in integrating your project into the overall planning of the municipality or the region, in finding support "in kind", in skills, in voluntary work or even in financial contributions.

Your project needs the local community

An attractive tourism activity must create a unique experience and have several attributes, not all of which are directly related to tourism-specific infrastructure. These are the attributes that define the attractiveness of a territory and are related to the services offered to citizens, to their courtesy, and to the quality of life: friendliness and the welcoming state of local residents, artist and cultural centers, the appeal of the landscapes and its natural environment, its hotels and services, local food, cultural events, affordable standard of living, the quality and variety of products, information and tourist services.

(Source: Cracolici and Nijkamp, 2008)



KEY POINTS TO REMEMBER

What makes a good project?

A good analysis
of the territory
and the trails

The ability to
ask the right
questions

A clear
assessment of
potential

The ability to
answer the right
questions

Solid knowledge
of users and the
market

Support from
authorities

An environmental
compliance

Support form
communities

The
involvement of
partners



CREATE THE MASTER PLAN OF YOUR PROJECT

5

The main objective of this planning stage is to build a global vision of the project and its progress.

This ordering of needs and tasks, with the definition of priorities and dependencies will greatly help you to design the key paths for the implementation of your project trails.

CHAPTER SUMMARY

- 5.1 Questions for guidance
- 5.2 The two founding principles
- 5.3 Legislative and regulatory frameworks
- 5.4 Predesign of routes and trails
- 5.5 Participation of the community and stakeholders
- 5.6 Financial, management and promotion prospects
- 5.7 Drafting of the master plan for your project





© Coll. S.Koenig: planning at the Chinese Mountaineering Association in Beijing, of a climbing-hiking village in Guangxi (China 2015)



© Serge Koenig Collection: planning a hiking-via ferrata project in the mountains of Xianju, Zhejiang (China 2014)



5.1- Questions for guidance

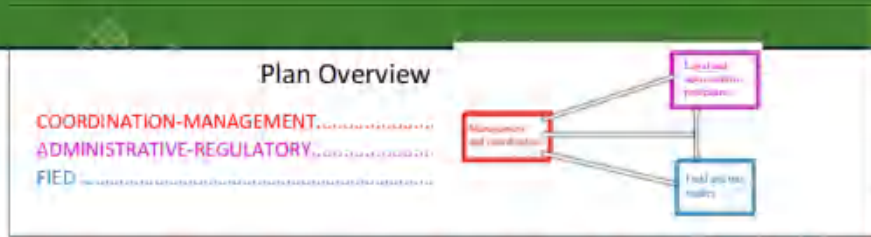

Questions concerning management and organizational approaches

Questions concerning the administrative and regulatory procedures

- **Have you positioned the imperatives of sustainability and accessibility at the center of your trail project?**
- **Do you know the types of trail experience you want?**
- **Are you clear on the target user segments?**
- **Can you estimate the frequency of use? Possible conflicts of use?**
- **Is your project compatible with an existing government strategic plan at the territorial level?**

- o Look for strategic programs at different administrative levels;
- o Contact the concerned administrations;

- **Do you have the support from the public authorities? What is their level of collaboration?**

- o Contact the concerned authorities;
- o Find out about the procedures to follow. What approvals are needed?

- **Are you familiar with the regulations for land, trails and hiking activities?**

- o Analyze the overall legislative context, in particular for trails and user rights;
- o Review the plans as much as necessary that may be linked with your project (cadastre, master and allocation plans, inventory of protected areas, etc.);
- o Identify the legal status of all the land crossed;
- o Do you know the regulatory framework for the region's protected natural areas?
- o Identify and consult:
 - the land managers and owners;
 - the local political council;
 - the concerned public services (for example the cadaster or sports service);
 - the relevant government agencies (for example a national agency for parks or a regional agency for forests);
- o Involve (as much as possible) in your project:
 - the managers and owners;
 - the public authorities;
- o Learn about the approval process of the landowners and managers;
- o Apply for the necessary approvals and authorizations from:
 - the public authorities;
 - the landowners;
- o Be aware of liability issues for damage and accidents, and the necessary insurance;
- o Study the best legal solution to ensure the durability of your trails and of their use;
- o Identify potential difficulties and explore the different solutions.

- **Have you gathered the data needed for the preliminary trail design?**

Questions about fieldwork

- Return to the field as often as necessary to complete the information related to the analysis of the territory and in particular of the trails;
- Understand the real conditions of the land, its geophysical characteristics, the local climate, the condition of the existing trails, the number of visitors or the flow of hikers, etc.;
- Check all the plans, maps, photographs, satellite views, etc., anything that can improve your knowledge of the field;
- You should ideally obtain a map showing the complete network of the existing trails around the area of your project;
- Comply with the compatibility between the natural environment crossed and the types of trails desired;
- Define the preliminary corridors of the desired hiking routes;
- Draft the design of each hiking route in the space of each corridor:
 - With the existing trail sections. Know how to justify your choices;
 - With the potential sections of new trails. Know how to justify the reasons for drawing these new sections;
 - Other options.
- Strengthen your arguments that will turn them into attractive trails and analyze the potential weaknesses that can compromise their success;
- Identify:
 - The obstacles and essential facilities and work that will have to be accomplished;
 - The lands crossed which require authorizations and agreements.

- **Have you started the process of joining and involving the local community?**

- With which:
 - authorities and administrations?
 - professional participants?
 - groups of trail users?
 - groups of residents?
 - media?
- Establish a reference group or a steering committee with representatives of these community groups and stakeholders;
- Set up collective and partnership governance shared with this reference group;
- Develop a collaborative relationship based on trust and transparency;
- Share your ideas, your concerns, your decisions. Hold consultations, involve them in the decisions;
- Develop a perspective of a "win-win" partnership.

- **Have you defined the operational modes for the management of your future trails?**

- Set the framework of the missions, responsibilities, and future objectives for the manager;
- Plan the basis for the future trail monitoring, maintenance and evaluation system;
- Look for ways to support these missions and sources of funding;

- **Have you defined the branding of your trails and the promotional arguments?**

- Specify the targets, offers, promotional arguments, communication networks, etc.
- Outline a promotion strategy with an estimated budget and a schedule.

- **Have you gathered the constituent elements of an estimated budget?**

- Include the expected costs of detailed trail design, construction, management for the first year (including trail maintenance), long-term management, promotional operations.

- Ideally integrate an estimated business plan indicating the profitability of future trails;
 - Make the balance between the expenses of the various budget items and the funding estimation;
 - List the sources of funding (in money, in kind, in expertise, in tools, in manpower, etc.);
 - Confirm the partnerships and supports, with a clarification of responsibilities, the nature of the supports (in money, in offices and premises, in expertise, in tools, in manpower, etc.);
- **Have you identified all the issues related to environmental protection?**
- Evaluate the impacts of the planned developments and the planned visits on the environment;
 - Check that the eco-responsibility regulations and standards are fully respected in the planned construction and operation;
 - Consult and stay in touch with institutional and associative organizations in this area (which can become project partners);
 - Plan an instructional and environmental education program for young people in your project.
- **Have you gathered the constituent elements to draw up the master plan?**
- **Have you acquired formal approvals and agreements from the government and landowner(s)?**



IF YES.....

Move on to the next phase of detailed trail design before construction...



IF NO.....

Identify the obstacles and reconsider the project at the level of the problem...



© Serge Koenig Collection: meeting with the administration of Huangshan and Panda Tourism for the creation of a nature trail (China 2018)



© Serge Koenig Collection: meeting with the authorities of the prefecture of Ganzi for the creation of a tourist trail and trail running around Gongga Mountain like the Tour of Mont Blanc, Sichuan province (China 2017)

5.2 – The two founding principles

Before embarking on your trail project, it is crucial to ensure that the proposal will be both sustainable and accessible to the users. These two imperatives will help you attract the target user segments, minimize the environmental damage, and maximize the opportunities for financing and the economic and social profitability of the trail operation.



Focus on the sustainability

It is crucial that the trails are ecologically, socially, and economically sustainable. It is therefore vital that a high quality of hiking experiences and the activity contents are compatible with the environments and landscapes.

Preserving and enhancing your natural spaces, protecting the biodiversity and cultivating a high level of environmental awareness must be the cornerstone of any development of a network of trails. This can be achieved through an appropriate design plan, the right selection of trail locations and continuous and appropriate management ([refer to: P1 - Chapter 12](#)).

The development of your trails must consider the expectations of users but also the sensitivities and desires of local communities. Joining and participation of trail users (hiking clubs in particular) and the local community (residents, related service sectors, etc.) are the determining factors in any hiking trail development policy. The joining of the community to your project will contribute to the debate and promote effective collaboration, generating trust, goodwill, and lasting support.



Focus on the accessibility for the users

The goal of sustainability must be reconciled with the need for trails to be accessible and user-centered.

The accessibility is determined in particular by:

- The proximity to local communities and tourist sites;
- The proximity of links with transport infrastructure such as stations or road networks giving access to the trail;

- The links, existing or planned, with other trails;
- The proximity of strong natural and cultural attractions;
- The existence of facilities such as parking lots, toilets, picnic areas, campsites, information centers, food outlets, and many trail-related services.

The focus on the user requires leading the project with a clear vision of what will be the final offer, which should be taken into account as much as possible among the principles of universal design below (particularly applicable for trails with high attendance).

The principles of universal design for a recreational walking trail "for all"

- Fair use of a trail that neither disadvantages nor stigmatizes a user segment ("Be Fair");
- Flexible use of a trail that adapts to a wide range of presences and individual abilities ("Be Included");
- Simple and intuitive use of a trail easy to understand, regardless of the users' experience, knowledge, language skills or level of concentration ("Be Smart");
- Clear and effective information for the users regardless of the ambient conditions or his sensory capacities ("Be Independent");
- An error tolerance for a trail which minimizes the risk of accidents in the event of unforeseen circumstances or recklessness user behavior ("Be Safe");
- A low physical effort requirement for a trail which can be used efficiently and comfortably with minimum fatigue ("Be Active");
- A scale and space suitable for the various target users, suitable for the greatest number (including people with reduced mobility) for easy trails ("Be Comfortable").





Photo: Alamy Stock



Cadastral notebooks of Mont d'Or (France)

5.3 - Legislative and regulatory frameworks

As another essential part of the process, it is up to you as the project leader to verify its feasibility within the framework of the regulations of your country and to familiarize yourself with the precautions required at this level.

This regulatory framework will influence the location of the trails, their development, use, management, operation, and maintenance. Legal liability issues relating to the activities of the future operator of the trails must be fully understood in their local legislative context.

LAND REGIME AND USE OF THE TRAILS AND ROUTES CORRIDORS

The concept of the route and the trail does not constitute a legal entity in itself; however, the routes and trails run through land corridors, the regime of which is determined by the land status and by the function assigned to the route.

When creating trails and routes, it is therefore essential to know the private or public status of the land corridors taken, and whether they are authorized for passing walkers.

The legal framework governing hiking routes may vary from one country to another, especially depending on the particularities of land law and the right-of-way regime. In any case, the promoter of a hiking trail project cannot free himself from a detailed and rigorous analysis of these legal constraints. Whatever the nature of the corridors taken, it is recommended to group together the trails development management under the responsibility of the same public developer, generally a local authority (cities, intercity structures, districts), to ensure rigorous and consistent consideration of this fundamental aspect of the creation of a route in compliance with the laws and regulations in force in the country and the region.

In most countries, setting up a hiking trail and developing the necessary structures and services, the project leader must obtain the required agreements, permits, authorizations and the right of way. In general, the holding of tourist leisure activities must comply with and be integrated into the development and the urban planning of the municipalities crossed.

The right to use public land must be obtained from the administrations and organizations concerned. On private land, the consent of owners or management organizations is also necessary; it is often the subject of tolerance for individual hiking practices, and contractualization for market organization practices.

Passages on private land or ways

The passage is subject to the agreement of the owner or operator. However, even if the owner expresses his agreement, it is always better to formalize this agreement by establishing a passage authorization agreement signed by the two parties, i.e. the owner and the project leader (generally a public organization), establishing the rights and duties of each party, the conditions/modes of use of the path (with or without authorization for other types of outdoor enthusiasts such as riders, mountain bikers, etc.), the charge of maintenance of the path, and the insurance, etc.

There are generally three options (in addition to the tacit agreement not recommended):

- Purchase of the trail surface;
- Trust for public land
- Right of way.

IN CASE OF ACCIDENTS OR DAMAGE OCCURRING ON A TRAIL

(refer to: P1 - Chapter 10)

Responsibility searches and repair requests may take place in certain cases of damage or accidents. A few general principles are as follows:

- The search in terms of responsibilities may concern the user, the owner, the developer and the local authority in the event of an accident;
- A hiker can be prosecuted if his behavior is deemed likely to cause damage to property or people;
- The liability of the owner of private land may possibly be engaged on the basis of the principle that an owner is responsible for his property;
- The developer of the trail can be implicated for not having ensured the safety of hikers, due to unsuitable or poorly implemented facilities, or a poor appreciation of the objective dangers or the risks incurred by the walkers;
- Theoretically, the structure providing information encouraging the use of a trail (guidebook, map, markings and signage, etc.) can also be blamed for providing insufficient or erroneous information.

In many countries where hiking activity is structured, the passage agreements provide that the community (or the trail manager) takes the place of the private landowner to assume any civil liability incurred by the latter, and that it subscribes to an insurance covering any damage caused by the hikers.

Whether there is a convention or not, the criminal responsibility of one or the other would remain whole if it was engaged.

Finally, whatever its role in the development of hiking routes, the local authority generally has the prerogative of ensuring the safety of citizens and must use its police power to do so.



However, these general rules must be read in the light of the laws and regulations specific to each country.





© Serge Koenig / Alpes-Sichuan Collection: work on a leisure center project and trails around Sancho Lake, Chengdu (China 2016)



© Serge Koenig, trail design with the Dianeige design office in Xiling Xueshan in Sichuan (China 2013)

5.4 - Predesign of routes and trails

Based on the data collected during the inventory of existing trails (refer to: P2 - Chapter 3) and in the light of various consultations (with public authorities, owners, communities, etc.), a more precise zoning of the project site must be carried out with the preliminary location of corridor spaces for the planned routes. The selection criteria could also be natural appeal, legal aspects, interest in "loops" or linear, connection with roads, etc. Generally speaking, upgrading existing underused and in bad conditions trails in your project area will be much less costly than building new trails.

This technical draft phase of the design of the trails should make it possible to start defining the approximate lines of the routes, their shapes (linear or looped), their starting points, their destinations, the villages crossed, the links to transport services, to points of interest, etc. (refer to: P2 - Chapter 1) without ever losing sight of the necessary coherence of the planned network of routes.

Are you opting for a "network of routes" or for a "network of crossroads" (refer to: P2 - Chapter 8)? This intellectual conception requires a certain experience and a good understanding of the principles of route layout, as it will prefigure, already at this stage, the marking and signage system that will be applied to the trails at the final stage of their creation.

If the scale of the network is a small area, it is preferable to provide a good number of paths in contiguous and superimposed loops (refer to: P2 - Chapter 1). Such system offers many options and an interesting variety of trail experiences avoiding the need to go back and forth on the same route. The routes may correspond to different user segments: a main trail in the center can be wide, comfortable, open, and fluid. While other loops that derive from it may be narrower, challenging, and steep.

Linear trails that connect two distant points will be more suited to longer-distance itinerant hikes. Forest roads or disused railway roads (see the specific indications in the box below) are generally excellent supports for linear and long-distance routes.

Other contexts are based on linear hiking and on shorter distances: there are descending trails of which the summit is accessible by a cable-car (for example as part of a summer activity offer in a winter sports resort).

These are only recommendations as all the principles expressed in the various preceding chapters are applicable according to the decisions of the project leader and the actual resources of the territory.

At this stage the different field investigations must have:

- Confirmed the lands crossed;
- Refined the knowledge of the topography;
- Worked on different route options;
- Defined the cohabitation with other users of the space, such as farmers, foresters, breeders, residents, outdoor sports practitioners, etc.;
- Confirmed the compliance of the project with the requirements or constraints with regard to animal and plant species and the nature in general (protected areas and species, sensitive areas, etc.);
- Anticipated potential obstacles and started the search for solutions;
- Involved as much as possible the expertise of the local community (associations, clubs, volunteers, etc.);
- Etc.

New investigations can be useful to refine and complete the useful and various technical information: on the nature of the soils, on local climate's impact on the trails, on the different environments crossed (areas of users falls risk or rockfall, marshy areas, places exposed to erosion, etc.), and on the heavy installations to be envisaged, such as pedestrian bridges, safety equipment, and backfilling works. The investigations must also verify which natural materials are available on the terrain of the trails, for example wood, gravel-sand, stones (their use in the construction of the trails will reduce transport and the overall cost). This information will be considered in the establishment of a first estimated budget for implementation, just as much as in the detailed design of the trails (refer to: P2 - Chapter 6).

Performing these tasks requires extensive technical knowledge. Knowledge of materials and construction methods are as important as maintaining contact with landowners and administrations, or as identifying investment risks and controlling costs.



These field procedures should be entrusted to field specialists, who are as keen on trail / hiking issues as they are on the detailed content of your project.

Special case of railway trails

Railways trails are generally developed paths on abandoned corridors that can be used for walking, cycling and horseback riding. Most of the trails of this nature have been covered by gravel or earth after their conversion from train to hiking, making them better suited for this use.

The route of the railways generally starts from the city, cuts through the hills, under roads, on embankments, through ravines and the streams, connecting the pastures, the rural lands, and the villages. These flat and never steep routes and the different environments the trails go through are generally very suitable for hiking.

Rails and their sleepers are often removed after a railway line has been taken out of service. Bridges and tunnels are neglected. The upgrading of infrastructure and the establishment of the walking circulation surface are the main development works to accommodate hikers.

A clear understanding of the infrastructure and maintenance requirements is a major consideration in the feasibility study of a railway trail. Specific treatments may be necessary on contaminated and potentially risky sections for walking users. And most of the railway trails, like other trails, will require orientation and information signs, public accesses with parking spaces, and sometimes guardrails or fences...

A solid assessment must be carried out on the risks and security needs of users. A code of behavior must be drawn up for the use of the path generally shared between hiking, cycling and horseback riding.



© Serge Koenig: Wild ibex on the Aiguilles Rouges trails, Chamonix, Alps (France 2020)



©ERA-EWN-FERP archives: meeting with partners and members about E-Path (Norway 2012)

5.5 - Participation of the community and stakeholders

The planning, development and management of your trail project should involve a number of organizations, groups and individuals who can be involved and even become valuable partners. From this stage of reflection, it is opportune to start mobilizing a "production chain" taking into account the local economic, heritage and socio-cultural elements. It is indeed not enough to only create and develop trails, but also necessary to develop the system that will allow them to live sustainably.

Projects that include real and transparent consultations are more likely to be successful because stakeholders can participate from a shared and mutually acceptable concept.

It is therefore preferable to involve the community and interested stakeholders from the phase of defining the political objectives of the project or as early as possible in the planning phase of the project. And it takes the time and energy to engage in these community consultations to inform, involve, and gain the approval and support of all.

According to the complexity of the project, meeting arrangements may include:

- The local government or representatives of the various concerned municipalities (even at higher administrative levels);
- Land managers and owners (at least the main one(s));
- Local organizations and agencies (or even at higher administrative levels) in charge of the conservation and the environment;
- The professional sectors of tourism, transport, accommodation, trade, guides etc. ;
- Groups of trails users or potential users;
- Educational institutions, including local schools and universities;
- Training agencies;
- Clubs and associations of volunteers, seniors;
- Health agencies;
- Etc.

Their early participation and influence should help:

- The project leader to support the choices and decisions which must be submitted to the public authorities and other key decision-makers;
- The local community to "take ownership" of the project and get involved at each stage of its development by visualizing the potential economic and social benefits.

TABLE: the participation of the community, its stakeholders and its citizens in a trail project can be considered at different levels

	Information	Consultation	involvement	Collaboration	Empowerment
Purpose of public participation	To share objective and transparent information with the public on the project, its goal and its issues	To obtain "feedback" from the public on analyzes, suggestions for alternatives and decisions	To ensure, through working directly with the public, that the community's issues and concerns are constantly understood and considered.	To obtain, through a partner relationship, an active participation of the public in all aspects of the project, with the analysis of alternatives and the most appropriate solutions.	Entrust the final decision to the community
Promise to the public	We will keep you systematically informed	We will listen to your concerns, and inform you about how your contributions influence choices and decisions for the project	We will work together on taking into account your concerns and your issues in the choices and alternatives, and we will give you "feedback" on the decisions.	You can advise us directly and participate in the design of solutions. And your recommendations will be incorporated as much as possible into the decisions.	We will implement what you decide.
Example of tools	- Descriptive sheets - Websites - "Open doors"	- Public comments - Discussion groups - Investigations - Public meetings	- Workshops - Surveys - Deliberation	Citizens' committees: - to express their opinions; - to reach a consensus; - to participate in decision-making.	Citizens' juries: - to vote ; - for the delegation of decisions.

Beyond joining and participation in the planning of the project, the aim of this community involvement is to encourage the participants to start organizing themselves in order to be able to gain their own profits from the project, and to take charge of the various actions that are relevant to them: hotels, various accommodation facilities, catering, taxis, sale of souvenirs, hikes guiding, etc.

Training (which is generally the responsibility of the project leader or an associated public service) plays an important role here. It helps to professionalize the service providers or essential sectors to the proper development of trail and hiking products. It also instills, if need be, a "hiking culture" to those who will be in contact with customers (hotels that will host walkers should, for example, have a good knowledge of the hiking activity and the local trails).

Recourse to an expertise structure outside the territory (but knowing local customs and traditions) can provide the interface and mediation between the project leader(s) and local participants to facilitate an integrated and intersectoral approach. Such a consultant structure will have the advantage of bringing its experience gained in other regions or other countries and a perspective that is both fresh and distanced. This interface role can consist of organizing joint reflection meetings between all stakeholders, facilitating the ownership by all the project, finding complementarities between the different sectors and collecting suggestions, etc.

TABLE: Simple methods are used to consult and engage the Community's stakeholders. Below is a framework on the objectives sought and support actions.

OBJECTIVES

	Forward information	Keep informed and Provide updates	Identify questions and issues	Develop goals and issues	Develop options	Test ideas, prioritize options	Building relationships involve participants	Building consensus	Reaching a large number of stakeholders	Reaching people who are reluctant to participate	Influencing small groups/ individual contacts	Gather opinions during the decision making process	Comply with regulatory requirements
Stakeholders are informed	Announcement	Blue	Blue						Blue	Blue			Blue
	Mail, phone call	Blue		Blue			Blue		Blue	Blue			Blue
	Newsletter, brochure	Blue				Blue			Blue	Blue			
	Internet	Blue		Blue		Blue			Blue	Blue		Blue	
	Signs, charts, plans	Blue							Blue				
	Posters, exhibitions, signages	Blue		Blue			Blue		Blue	Blue		Blue	Blue
Stakeholders are invited to participate	Meeting with key persons	Dark Blue	Dark Blue	Dark Blue	Dark Blue	Dark Blue	Dark Blue	Dark Blue	Dark Blue	Dark Blue	Dark Blue	Dark Blue	Dark Blue
	Contributions from interested parties	Dark Blue	Dark Blue	Dark Blue	Dark Blue	Dark Blue	Dark Blue	Dark Blue	Dark Blue	Dark Blue	Dark Blue	Dark Blue	Dark Blue
	Telephone assistance	Dark Blue	Dark Blue	Dark Blue	Dark Blue	Dark Blue	Dark Blue	Dark Blue	Dark Blue	Dark Blue	Dark Blue	Dark Blue	Dark Blue
	Surveys	Dark Blue	Dark Blue	Dark Blue	Dark Blue	Dark Blue	Dark Blue	Dark Blue	Dark Blue	Dark Blue	Dark Blue	Dark Blue	Dark Blue
	Presentations to groups	Dark Blue	Dark Blue	Dark Blue	Dark Blue	Dark Blue	Dark Blue	Dark Blue	Dark Blue	Dark Blue	Dark Blue	Dark Blue	Dark Blue
	Meeting with local community	Dark Blue	Dark Blue	Dark Blue	Dark Blue	Dark Blue	Dark Blue	Dark Blue	Dark Blue	Dark Blue	Dark Blue	Dark Blue	Dark Blue
	Groups meetings with local community	Dark Blue	Dark Blue	Dark Blue	Dark Blue	Dark Blue	Dark Blue	Dark Blue	Dark Blue	Dark Blue	Dark Blue	Dark Blue	Dark Blue
	Community event	Dark Blue	Dark Blue	Dark Blue	Dark Blue	Dark Blue	Dark Blue	Dark Blue	Dark Blue	Dark Blue	Dark Blue	Dark Blue	Dark Blue
	Open house information session	Dark Blue	Dark Blue	Dark Blue	Dark Blue	Dark Blue	Dark Blue	Dark Blue	Dark Blue	Dark Blue	Dark Blue	Dark Blue	Dark Blue

(Sources: DELWP Services - Environment, Land, Water and Planning - Victoria State Gov, Australia)



© Serge Koenig / Alpes-Sichuan: signing of a memorandum for the creation of an outdoor center in Dujiangyan (China 2014)



© Alpes-Sichuan Collection: cooperation project documents

5.6 - Financial, management and promotion prospects

At this stage, it is also a matter of planning how the project will be financed, who will invest in it, how it will be managed and how it will be promoted.

FINANCIAL AND INVESTMENT PROSPECTS

The potential avenues for participatory investments (financial, human resources, in-kind, others) in a trails project are in particular:

- Governments, public authorities at different administrative levels, approved agencies at local, regional, state level in charge of recreation, tourism, health and well-being, natural environment, etc. who can subsidize the project and even insure and pay for the maintenance of the trails, taking into account the social and societal profitability for the local community;
- Community organizations such as clubs / associations that use trails to develop their own activities. These organizations, generally important partners for the governments, can attract grants, sponsors and hiker membership fees, and they can be valuable partners in developing and maintaining the trails;
- Industrial groups (clean or renewable energy companies, for example) who share the values carried by hiking (respect for the environment, social profitability, soft development, etc.) and who are looking for a communication medium. These companies can rely on the metaphor and the virtues of the hiking activity, sponsor the trail project (sponsorship or patronage), finance the recruitment of young people from the community looking for work with the intention of working on your project, fund an annual event on the trails, fund environmental education activities for young people, etc..

It should be noted that funding for the creation, improvements and extensions of trails is generally easier to obtain than permanent operational funds. Please note, the costs of routine maintenance and replacement of facilities on the trails (for example, pedestrian bridges, steps, signage, etc.) are often underestimated and sometimes ignored: these are, in the long term, a source of possible abandonment of the project. The lifespan of trail elements and their replacement must therefore be considered in budget studies.

This preliminary budget study should make it possible to set an estimated budget to be included in the master plan which will conclude the planning phase. This budget must include an estimate of all expenses related to the planning, implementation of works, promotion, management (including a system of observation), maintenance and evaluation of the trails that will be implemented. The final budget will be further refined in the next phase of the detailed trail design.

The long-term investment and financing strategy can rely on additional financial, and the "in-kind" sources as mentioned above, to which certain income linked to the operation of direct services on the trails may be added: snack bars, camping site, refuges, selling guidebooks, hiking guide services, etc., and possibly trail access taxes according to their type (interpretation trails, for example).

TABLE: potential sources of funding for tourist or recreational trails

vv = very appropriate and potential for a major contribution
v = least appropriate or for a minor contribution
x = unlikely

Source of funding	Emblematic trails with strong tourist components	Community trails for recreation, health, well-being, collective equipment
Partnership with land managers and government grants	vv	vv
Subsidies and various partnerships related to confidence in the project, with companies and associations	vv	vv
Philanthropic donations	vv	vv
Sponsorship	v	vv
Direct income from paid access to the trails	vv	X
Indirect income from services to trail users	vv	v
Various contributions from commercial tour operators for the use of the trails	vv	X
Sales of information (such as guidebooks)	vv	X
Sales of by-products	vv	X

The progressive development strategy

The trail project can also be spread over time with the launch of the construction of a first pilot trail and then the gradual widening to a network of trails depending on the success. In this way, the cost can be broken down and scaled over time, limiting the risks of an overall investment all at once.

A trail project that finds its place in general planning, development, tourism at the local, regional or national levels will be easier to finance insofar as it contributes to government objectives.

OPERATING MODES PROSPECTS

The type of your project and its objective (private, public, or mixed project; community, touristic or purely commercial objective) define the type of management that will be applicable. However, the planning phase constantly readjusts the components of the project which are not fixed. These operating modes can be modified and refined but they must be considered and established as part of the investment strategy. Very often the business model is decided upon towards the end of creating a new trail or when an existing trail becomes a financial burden and things need to change...

The contractual and non-contractual stakeholders involved in the development of the project must participate in defining the best management model. But there isn't any universal model that fits all situations. The ultimate test of whether the operating regime is working or not actually lies in its sustainability. If a quality hiking experience offered to users is not compromised by a lack of funding or organization, of economic and community profitability, the project is likely to be sustainable.

Several models may be suitable for different trail scenarios ([refer to: P1 - Chapter 4](#)), and each model has its advantages and disadvantages: please see the table below.

TABLE: the 3 main management models

Management model	Main characteristics	Situations conducive to the application of the operating mode <i>(However, the adequacy between the management model and the particularities of a project and a territory may vary depending on the general administration mode and regulations of each region and each country).</i>
100% public Led by a single government organization or a public interest organization	The government agency is responsible for managing the trails and sometimes the entire site. Services related to the trails may or may not be provided by private service providers with the potential existence of commercial licenses (guide services, tour operators, accommodation, etc.). These trails are generally on public land. Private land may be crossed by minor sections of the trails within the framework of rights of way and agreements with the owner. This is generally a nonprofit management model except for related commercial services.	It may involve projects: <ul style="list-style-type: none"> - On ecologically sensitive sites to be preserved; - On public sites in places far from population basins and for which it is difficult to find partnerships; - On sites with the presence of several land users and which require a neutral and single manager to preserve access to recreational and hiking activities in the face of the complexity of the many different interests involved; - Pioneering projects with pilot trails, where the government takes the risk and puts in place the infrastructure with the aim of establishing partnerships with other stakeholders over time; - Etc.

<p>Public, private or mixed partnership</p> <p>Led by two or more organizations</p>	<p>There are many different forms of partnerships, from joint ventures to subcontracting, through outsourcing, and potentially combining organizations with different rights (public - local authorities and State-companies and private-companies for commercial purposes, associations for non-commercial purposes, etc.). These alliances are characterized by the sharing of goals, risks, investments, resources, responsibilities, and profitability.</p>	<p>It may include all types of projects, even those carried out in environmentally sensitive sites. Under the right circumstances indeed, Public-Private Partnerships (PPP) can enable governments to lead project development in accordance with government priorities and high environmental and social standards, while harnessing the efficiency and creativity of the private sector.</p>
<p>100% privat</p> <p>Led by a single private legal entity</p>	<p>The manager of the private entity is responsible for the operation of the trails, related services and generally the entire site, which he/she often owns. These trail offers are in fact generally on private property. They can exist within the framework of concessions. This is generally a for-profit management model</p>	<p>It may involve:</p> <ul style="list-style-type: none"> - A private domain in a region in which public spaces and natural resources do not have sufficient potential to develop a quality hiking offer; - A private domain in a region where the private operator can more easily build specific facilities and offer a trail experience different from those existing elsewhere in the region, and thus attract new segments of practitioners; - Land and natural resources allocated in concession by the State or by an owner to a private operator, free of charge or for a fee, with the aim of enhancing and developing them for recreational and tourist activities, etc..

TABLE: advantages and disadvantages of the 3 main management models

Model	Examples of advantages	Examples of disadvantages
<p>100% public</p> <p>Led by a single government organization or a public interest organization</p>	<ul style="list-style-type: none"> - Clear role and responsibility; - Rapid decision-making; - Easier application of required environmental and social standards, and general service. 	<ul style="list-style-type: none"> - The social, economic, cultural and environmental benefits, and the sustainability of the activity, are dependent on the capacities and performance of the managing agency; - The project is dependent on a single organization to get funding and other support.
<p>Public, private or mixed partnership</p> <p>Led by two or more organizations</p>	<p>The co-management between stakeholders leads the organizations to better performance in terms of stability and profitability. It shares risk, reduces operational costs, improves service levels. The partnerships make it possible to exploit a broader base of support for maintenance, development, funding, extensions, events.</p>	<p>The heterogeneity of partners can make their cooperation confusing and difficult: types of conflict are numerous and can affect group processes and outcomes. Stakeholders are obliged to enter into management agreements so that the roles are clear. They share control and responsibilities with a risk of reducing the effectiveness of decisions.</p>
<p>100% privat</p> <p>Led by a single private legal entity</p>	<ul style="list-style-type: none"> - Potentially effective decision-making; - Less political interference in the decision-making; - Can quickly respond to market preferences and evolution; - Can offer experiences different from those offered by public services. 	<ul style="list-style-type: none"> - Activity may be stopped and the trail may be closed without public consultation or notification; - Vulnerable to economic conditions; - Usually only able to cater for a small or medium volume of visitors.

Whatever management model you choose, there are many questions that you must be able to answer:

- What training needs will emerge? Will the tools be in place?
- How can the accommodation facilities be upgraded? Means of transportation?
- How will providers organize themselves to offer the best services and obtain optimum economic efficiency?
- Who will ensure the promotion? The commercialization?
- Who will maintain and monitor the trails?

MONITORING AND MAINTENANCE MODES PROSPECTS

This is an essential part of the trail operating mission. The trails conditions change over time, especially during winter and rainy seasons. Their attendance also affects the environment on different levels. (refer to: P1 - Chapter 5 and P2 - Chapter 6)

It should be noted that many ecological components are themselves interdependent and the degradation of one of them can lead to a cascade of peripheral degradation. For example, the alteration of the vegetation cover accelerates the erosion process of the soil surface; this erosion then modifies the drainage by capturing rainwater, which also helps to accelerate the erosion process. Then, the degradation of a poorly maintained trail will affect the experience of trail users. And when the trail is severely degraded, users will seek to circumvent this obstacle, which will result in the widening of the trail or the appearance of informal trails parallel to the main section... This spiral can lead to the abandonment of trails because of their poor condition.

The regular and/or seasonal observation and maintenance of the trails will therefore be influential factors in ensuring their durability and offering a good product to hiking practitioners.



The "trail monitoring, maintenance and evaluation system"

Some damages, which are obvious to spot, will be noticed by users or during the regular maintenance program. But other damages that occur over an extended period are more inconspicuous and may not be noticed until they become a problem (refer to: P1 - Chapter 6 and P1 - Chapter 12). Hence the importance of establishing a system for monitoring, maintaining, and evaluating trails.

Its role is:

- To measure whether the trails and environmental values are preserved or are deteriorating;
- To define the tools to identify priorities and allow the trail manager to direct resources to priority work;
- To keep accurate records of the condition of the trails;
- To interact regularly with users.

A series of measures can be implemented to encourage user comments following their hike:

- Information panels at the entrance to the trails, brochures and guidebooks can, through information, encourage users to report any damage, illegal dumping, etc. by telephone, Email or via a website on which anyone can connect to send "feedback" or an alert;
- The manager can also be proactive in seeking feedback that he can solicit by organizing a questionnaire or online survey.

The most common maintenance interventions are small-scale cleanup work, rainwater drainage, replacement of damaged trail markings or installation of missing markings.

Such a "monitoring, maintenance and evaluation program" must be included in the list of tasks of the trail manager during the planning phase, and it must be financially evaluated. This budgetary assessment is complex as the variables induce major differences, even within the same country. The maintenance mission will cost more for trails in the areas listed below:

- Rainy climate areas as water is the main enemy of the trails;
- Areas in the mountains because of the difficulties in transporting tools and materials (on the backs of men, animals or by helicopters).

The way in which these missions are carried out is also a factor influencing their costs, and labor is often the main item of maintenance expenses. It may therefore be relevant to reason in terms of necessary working time. The involvement of volunteers from associations can reduce direct costs as it is practiced in countries where the recreational and tourist hiking activity is well established (refer to: [P1 - Chapter 5](#) and [P1 - Chapter 4](#)). But the maintenance of this tourist infrastructure, which are the trails, is generally the responsibility of local communities, which can be helped by higher administrative entities (county, departments, regions, etc.). Trail maintenance sites can also be integrated into social inclusion programs (involving offenders sentenced to community service for example) or back-to-work assistance schemes. (refer to: [P1 - Chapter 6](#))

In any case, the integration of such a program which ensures the sustainability of the trails is a structuring element, if not essential, to raise the funding for the implementation of your project.

Among its other missions, the "monitoring, maintenance and evaluation program" must also predict changes in practices, in attendance, and in possible conflicts of use between different activities that come to share the trails with hikers, etc. The result of this evaluation must identify the causes of these changes and help the manager to implement the necessary measures to readjust his offer of hiking experience and to supervise the activity.

In order to ensure the feasibility of the "Track Monitoring, Maintenance and Evaluation System", the project plan must clearly specify the various resources required to perform this task:

- What agency or organization?
- For how long?
- What possible partnerships?
- What annual budget?
- Who finances it

PROMOTION PROSPECTS

The users of your trails will certainly come from two key groups:

- Those who live locally and can access activities directly from their homes or by driving a short distance (permanent recreation and local tourism). They are generally familiar with the area and are first and foremost looking for a well-maintained network of trails for hiking in good conditions.
- Those who live elsewhere and who travel to the region as part of a weekend or vacation outing during which they walk on the trails that complement the wider tourist offerings. In addition to the same expectations, many of these tourist hikers need to be guided and informed. For the most part, these are non-specialists who want to be able to lead their outing easily. Hence the need to set up well-designed routes with directional signage and uniform and simple markings, which are understandable by all. (refer to: P1 - Chapter 5 and P2 - Chapter 8)

The ideal goal is to keep local residents happy while attracting more visitors by giving them the opportunity to freely have a good time in the region where they are going to stay and spend their money. This conception of the offer of shared trails and nature is most common on the "hiking planet" and what we focus on in this "guide".

Unless you develop a network of trails in the framework of a top destination that does not need to be known, the development of your project may require promotional operations with target users. Providing this value-added element of the trails for the users must be part of the planning phase. The main actions will be:

- Information on the ground (information points and offices);
- Multimedia support (websites, CDs, paper);
- Promotion (advertising campaigns, media);
- Animations and demonstrations that arouse a desire to come to tourists.

If you work with a tourism marketing professional, ideally specialized in outdoor activities, this specific work will be at his charge, and it will help you in defining the best strategy:

- 1- Be clear about your overall communication goal... Who do you want to contact, when and why?
- 2- Know your audience: identify and list your different audiences. The analysis made by the reference group together with your project stakeholders should help you in identifying who to communicate with and why.
- 3- Clarify specific goals for each user segment within your overall communication goal. A good way to do this is to think about the needs of these audiences. List all of the goals (there may be several) for each user segment in your plan.

To be effective, you have to ask yourself the right questions by putting yourself in the shoes of the targeted users. What do they need? What do they want to see, hear, feel? What is their preferred way to receive information? When and how will these messages be delivered? What will prevent them from receiving this information? How do you know what they understood from the messages? And so on...

List all the possible communication channels that you can use, think broadly and creatively! These include (but are not limited to):

- General and specialized media;
- Social media (Facebook, WeChat, Weibo, etc.);
- Internet blogs and specialized websites (they exist in all countries and are innumerable, for example: chinawalking.net.cn; tubuzhe.com; dianfengtubu.com; fohoing.com; wandern.com; thebigoutside.com; hikinginjapan.com; americalhiking.org; hiking-for-her.com; bestkihe.com; indiahikes.com; randozone.com; visorando.com; randogps.net; camptocamp.org; i-trekking.net; tracerando.jimdofree.com; routeyou.com etc.);
- Email Lists
- Flyers, newspapers, newsletters;
- Community notice boards and other print media;
- Hiking events for the opening of the trails, topping-out ceremony, etc.

Define the appropriate messages for each specific user segment. Several messages over time may be necessary to achieve the goals for each user segment. You will need to make sure that the messages "add up" to achieve the goals set for these audiences.

It will be necessary to monitor the effectiveness of the process. You will need to interview message recipients to understand their views and see if they have understood the intended meaning of your messages. This "feedback" will help continuously refine your communication.



What are the marketing strategies towards the tourists (target outside the local community)?

Once again, we must understand this target group and verify the adequacy of the offer of hiking experience with their expectations.

If tourists from the region or further away are your key user group, local or even regional participants such as accommodation establishments, tourist offices, etc. should be involved in promoting the offer of your trails.

Ideally, the trails can be promoted as an integral part of the offer of regional tourism experiences and should be linked as much as possible to other products that attract visitors to the region. This approach integrated with the region's overall tourism marketing strategy is the most effective way to promote your local trails and hiking activities.

At this point, you will also need to think about how you will use social media in your marketing and permanent communication with tourist visitors to attract them to your trails. The site must be completely free, specifically dedicated to your hiking products to give an overview on the thematic and landscape samples, and if possible, available in several languages.

TABLE: useful insight into the visitor's decision-making process and the possibilities to get them interested in your trail offering via social media.

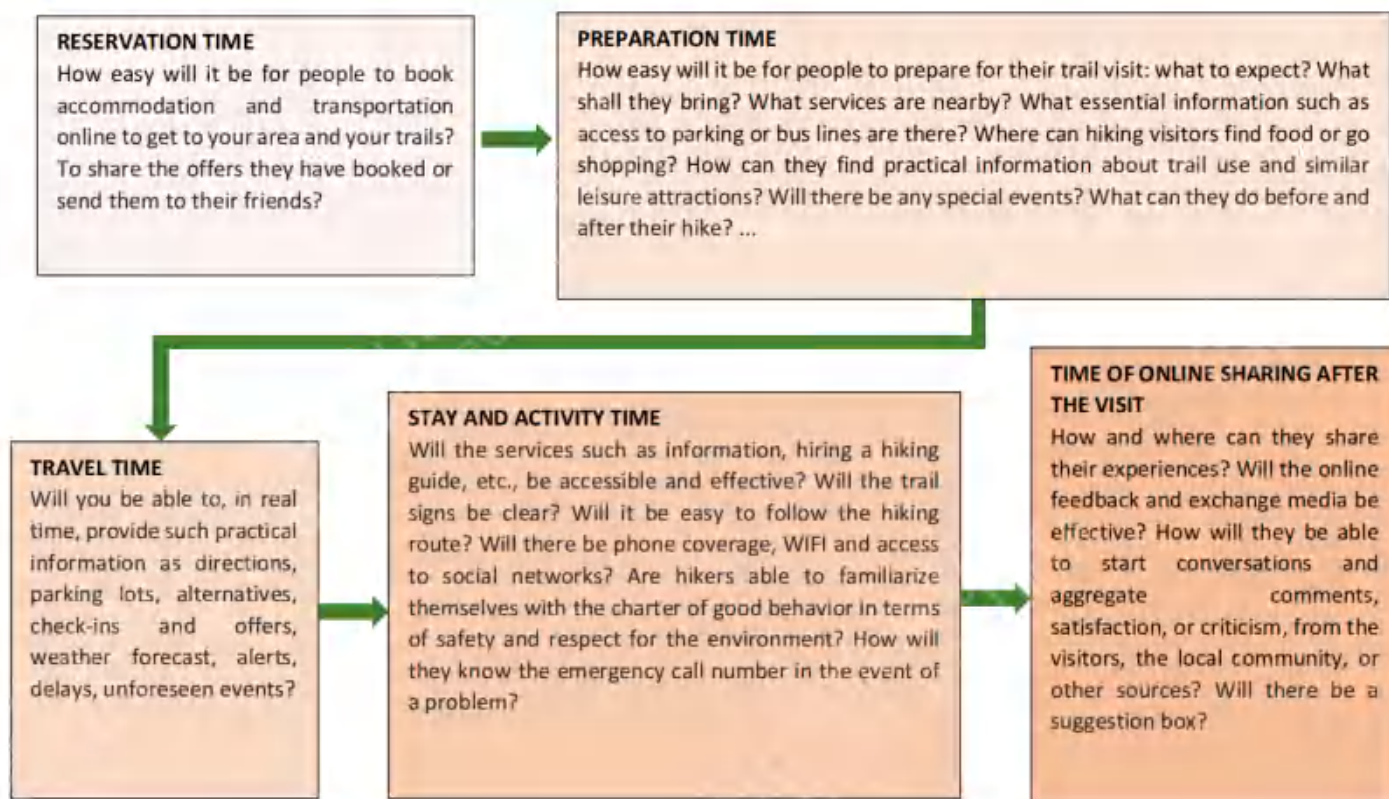

What are the marketing strategies towards local trail users (target of the local community for recreational activities, health, or well-being)?

The following list indicates actions (to be carried out in addition to or instead of the actions mentioned in the previous paragraph) that can be considered for this group of hikers living in the region:

- Communicate with associations and clubs for hiking, outdoor sports and fitness, well-being and health, families, retirees, etc. to see how they can participate in the development of hiking and walking activities on your trails and make them known within the community;
- Distribute paper brochures or e-brochures to a large list of groups of users within a radius of travel time to be defined (between one and four hours) according to the appeal level of your offer and according to the travel customs of the country;
- Make sure that the brochures are widely distributed to relevant tourist offices and sales outlets;
- Bring your project to life in the local and specialized media through press releases, articles, hiking trips reserved for the press and journalists, media activities, events;
- Plan to organize a regular events on the trails: trail-running, orienteering course, hiking & multi-sport running, night walking, charity walking, etc.

- Set up your own trail-style club (or a "Friends of ..." group) linked with your trails experience, that can help to organize events, public hiking trips, school outings, themed hikes, etc. and thus help to develop the business. This club can also encourage volunteering among passionate practitioners, and they can get involved in the supervision of events or in trail maintenance missions.



© Serge Koenig: lake between the cliffs of the Xianju volcanic massif, Zhejiang province (China 2017)

Example of a Master Plan map from the French design office www.Dianeige.fr as part of the Alpes-Sichuan cooperation, showing the planning of a network of new trails around a mountain resort project in Longmenshan in Pengzhou (China)

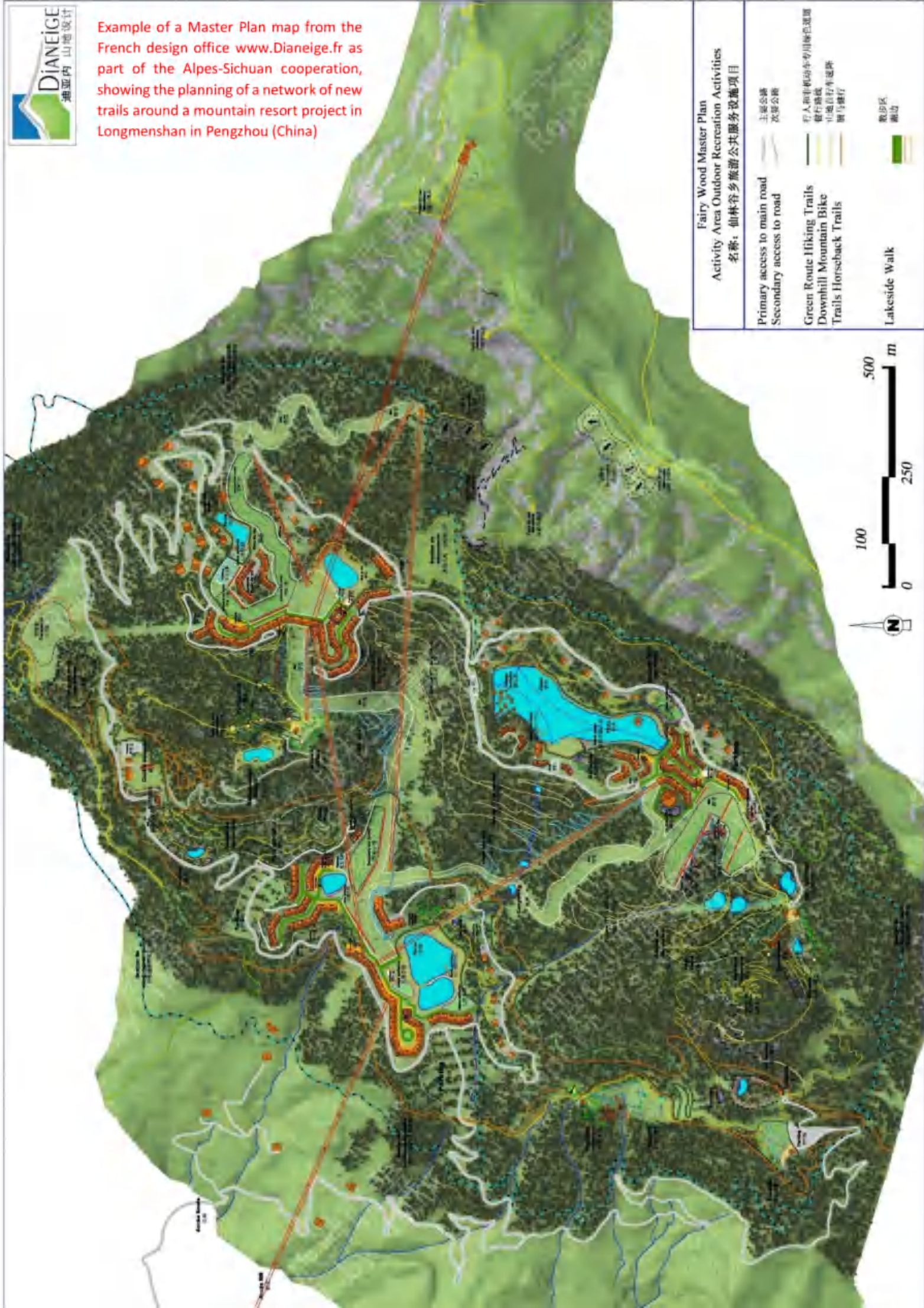

5.7 - Drafting of the master plan for your project

This is the documented feasibility study that concludes the planning phase.

This document is prepared to attract or confirm investment and other support for the project. According to the type of trails, the study should be prepared (or advised) by people competent in tourism or leisure planning, engineering, landscape architecture, economics, etc.

All important, strategic, cartographic, estimated data, etc. must be included in the master plan. Its size depends on the nature, scope, and purpose of the trail project. The following topic headings can be used as a guide:

- Introduction and goal of the project: how did the project come about? Why ?
- Context and opportunity of such a project: present the strengths and constraints of the region, the systems that drive it and in which the project will be anchored;
- Reminder of the laws and regulations concerning the project;
- Assessment of environmental resources, heritage, and land (private, public, protected, classified, open, etc.);
- Environmental commitments of the project: commitment to the respectful appreciation and protection of communities and cultural and natural heritage;
- Environmental commitments of the project: commitment to the respectful appreciation and protection of communities and cultural and natural heritage
- Planning process: is your project integrated into a local/regional/national level recreation, open space, or strategic planning design? With what government support? What approvals have you received for the project, etc.;
- Connections: the links created by the trails between villages and towns, with cultural, landscaped, tourist sites, etc.;
- Potential partnerships: with private interests and public authorities, project participation and support, roles and responsibilities of the organizations involved, etc.;
- Community contribution and support: public meetings, joining of the community, local authorities, their implications in the project and in the decisions, etc.
- Operating: modes, promotion, maintenance system and its financing, etc.;
- Access to trails: General public offer? Targeted offer for a niche market? Offer also open to cyclists? Riders? Disabled people? Etc.;
- Description and design of the project's trail system: the type of network, durability and accessibility of the planned trails, their main physical specifications (length, trailheads, noteworthy points, information and interpretation, signage and markings). Description of the construction and marking charter;

- Estimated budget: the approximate cost for the construction of the trails, the initial operating budget, the operating budget for its duration;
- Estimated funding: financial sources, voluntary and "in-kind" support;
- Estimated schedule;
- Conclusion: why does the project have to be implemented? What are the strengths and weaknesses of the project? What are the necessities required for its realization?
- In appendices, all other studies/reports helping to better understand the general environment of the project, as well as important information such as:
 - o The basic data;
 - o The regional context;
 - o The landscape resources;
 - o The natural and biological resources;
 - o The cultural resources;
 - o The points of interest;
 - o The land distribution;
 - o The classified protected areas;
 - o The existing facilities (roads, metro, train, bus, stations, parking lots, etc.);
 - o The surface reliefs and slopes;
 - o The pre-planning of the existing and new trail network;
 - o The different options

This project master plan must lead, if it has not already been acquired, to obtaining final approvals and agreements from the authorities, land-managers, and landowners.

Two options:



- Obtaining all the necessary papers \Rightarrow Continue with the detailed design of the trails
(refer to: P2 - Chapter 6)



- Refusal of approvals \Rightarrow Go back to reconsider the project and its problem

EXAMPLE: eight maps taken from the "Pinal County - Open space and Trails" study by Local Simpson Design INC (Arizona, USA)



LOGAN SIMPSON
DESIGN INC.

Map of land tenure and land use in the region (the project area is framed in black)

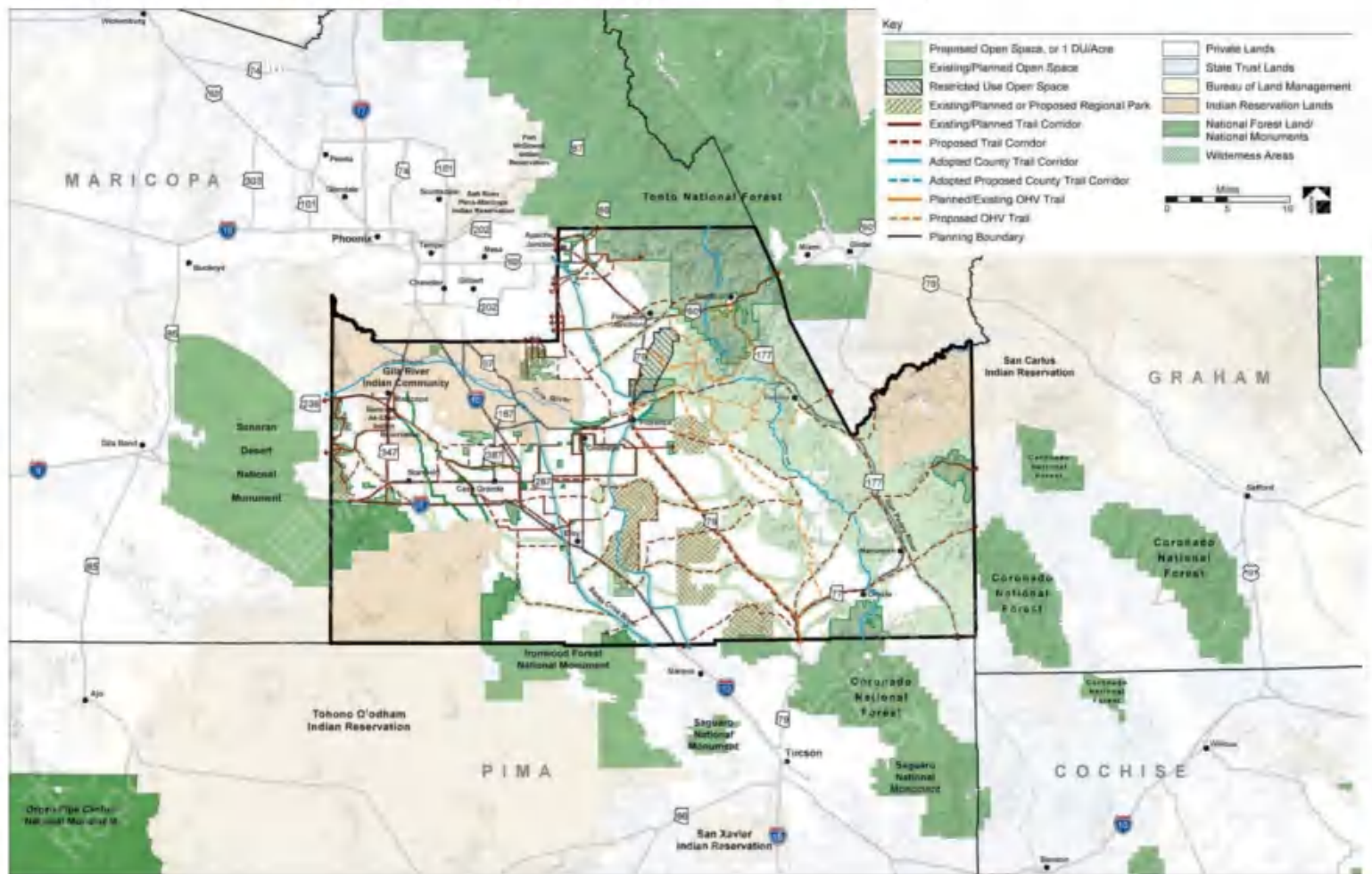

Map of land tenure and land management in the project area

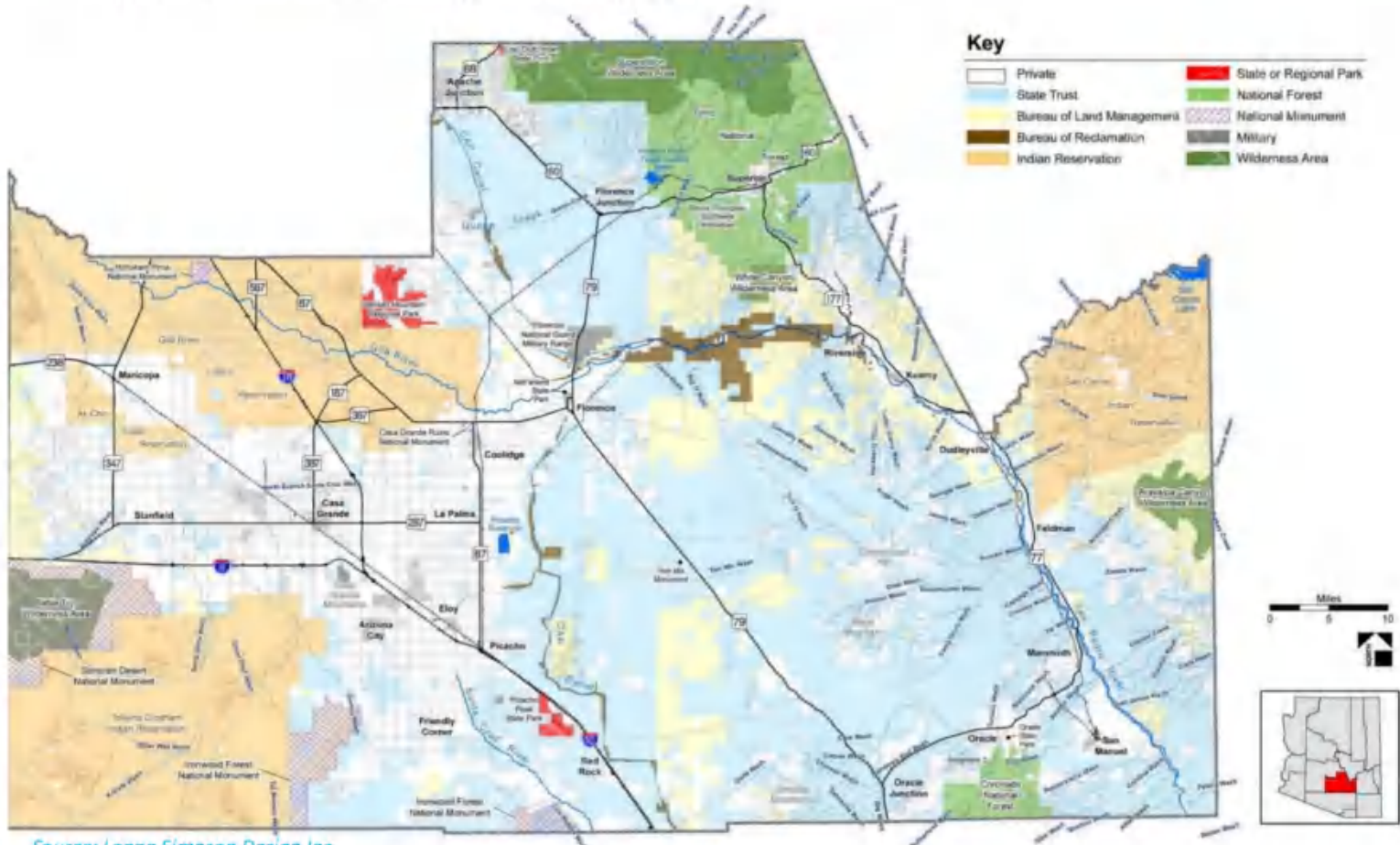

Map of land under development and construction in the project area

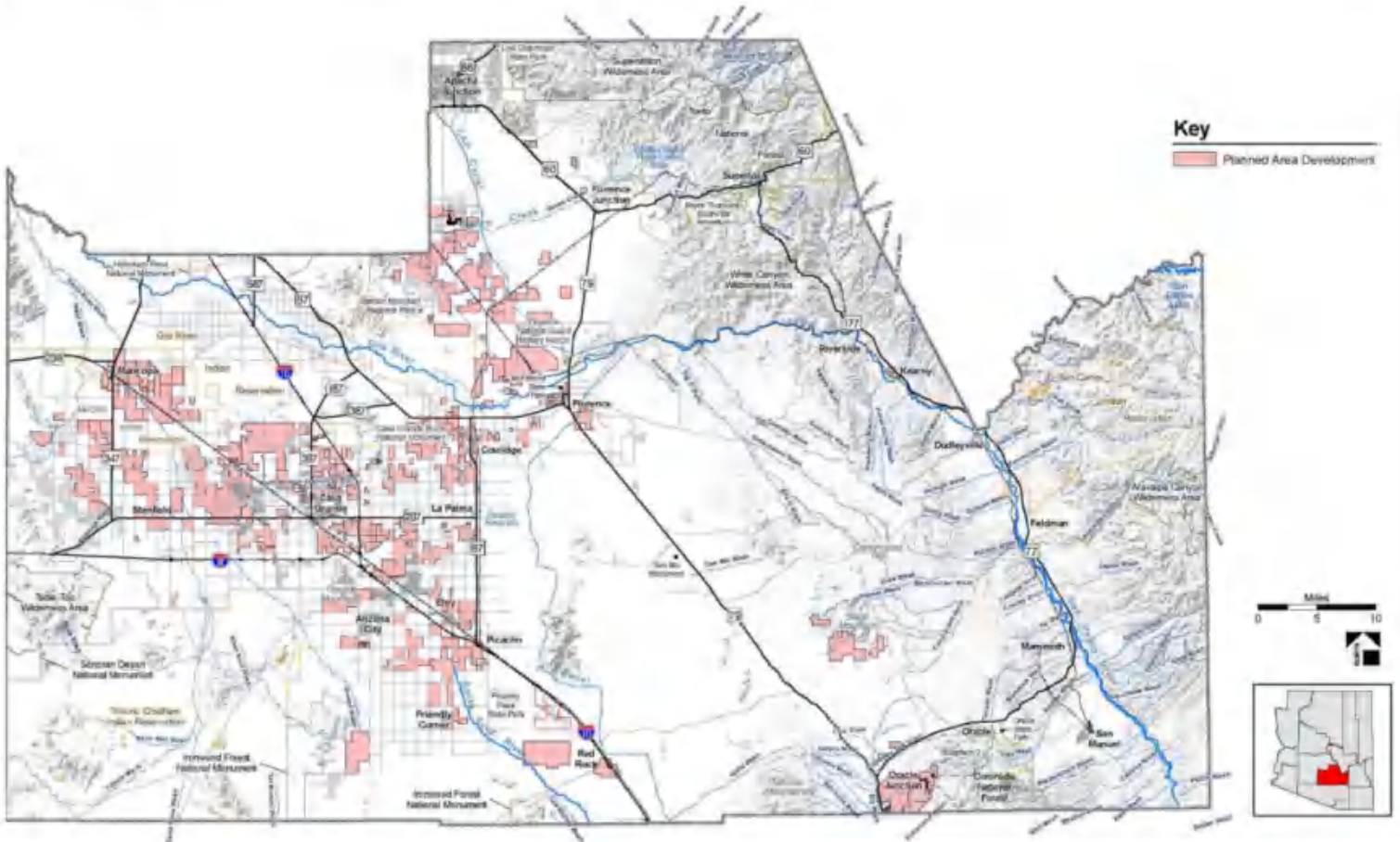

Map of cultural resources in the project area

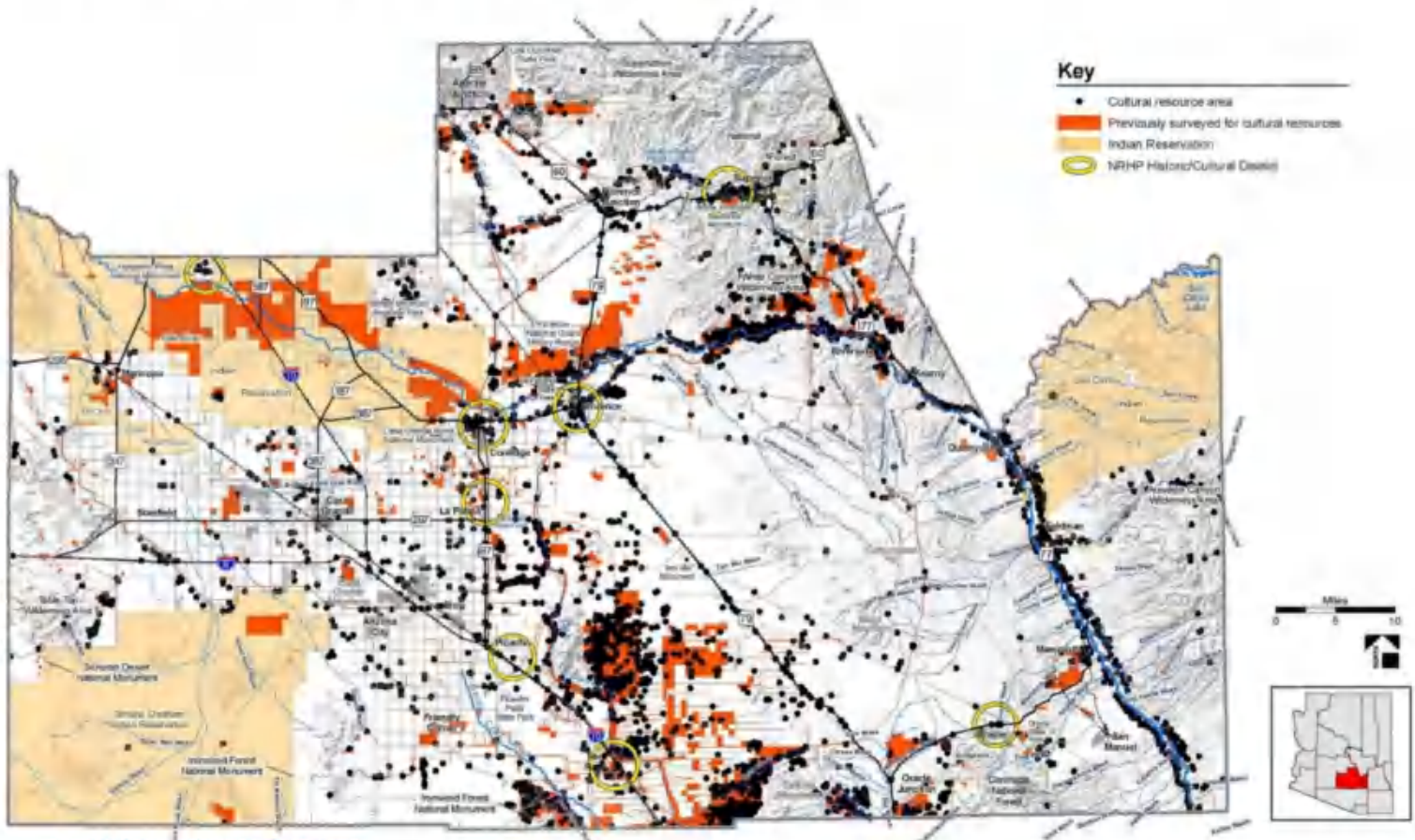

Map of biological resources: the density of birds in the project area

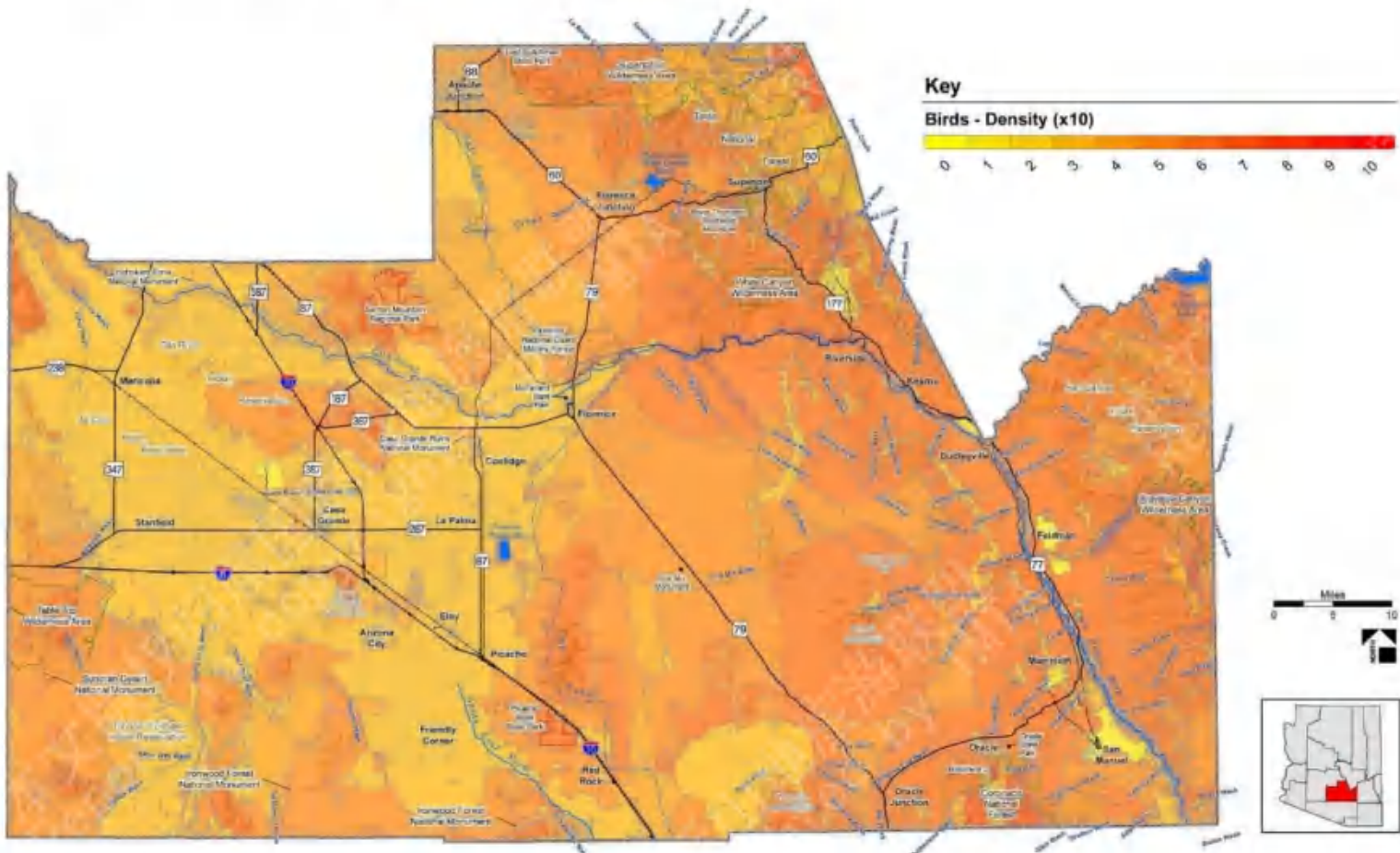

Map of surface reliefs and slopes in the project area

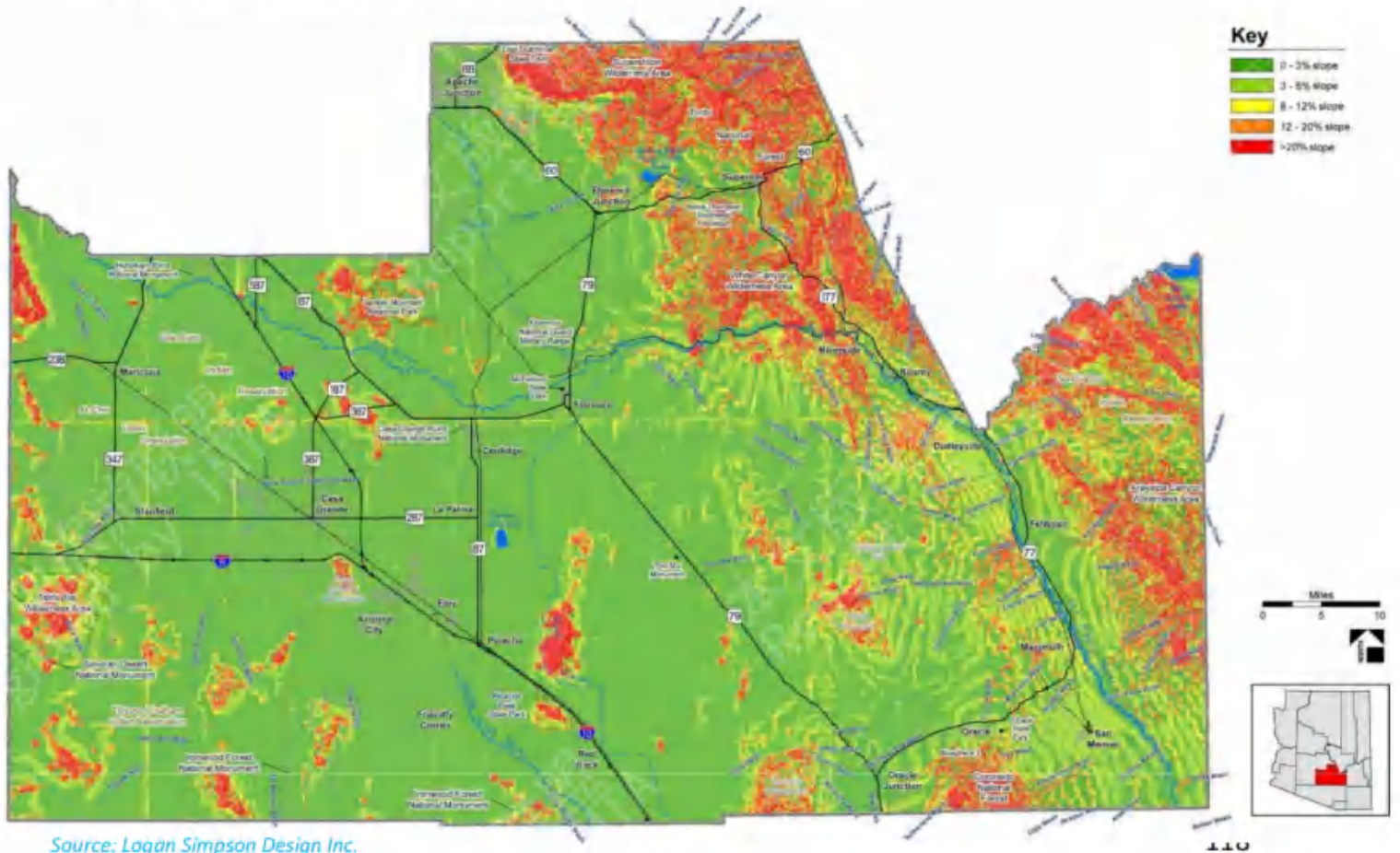

Source: Logan Simpson Design Inc.

Map of option 1 of the proposed trail network (solid lines: existing trails, dashed lines: new trails)

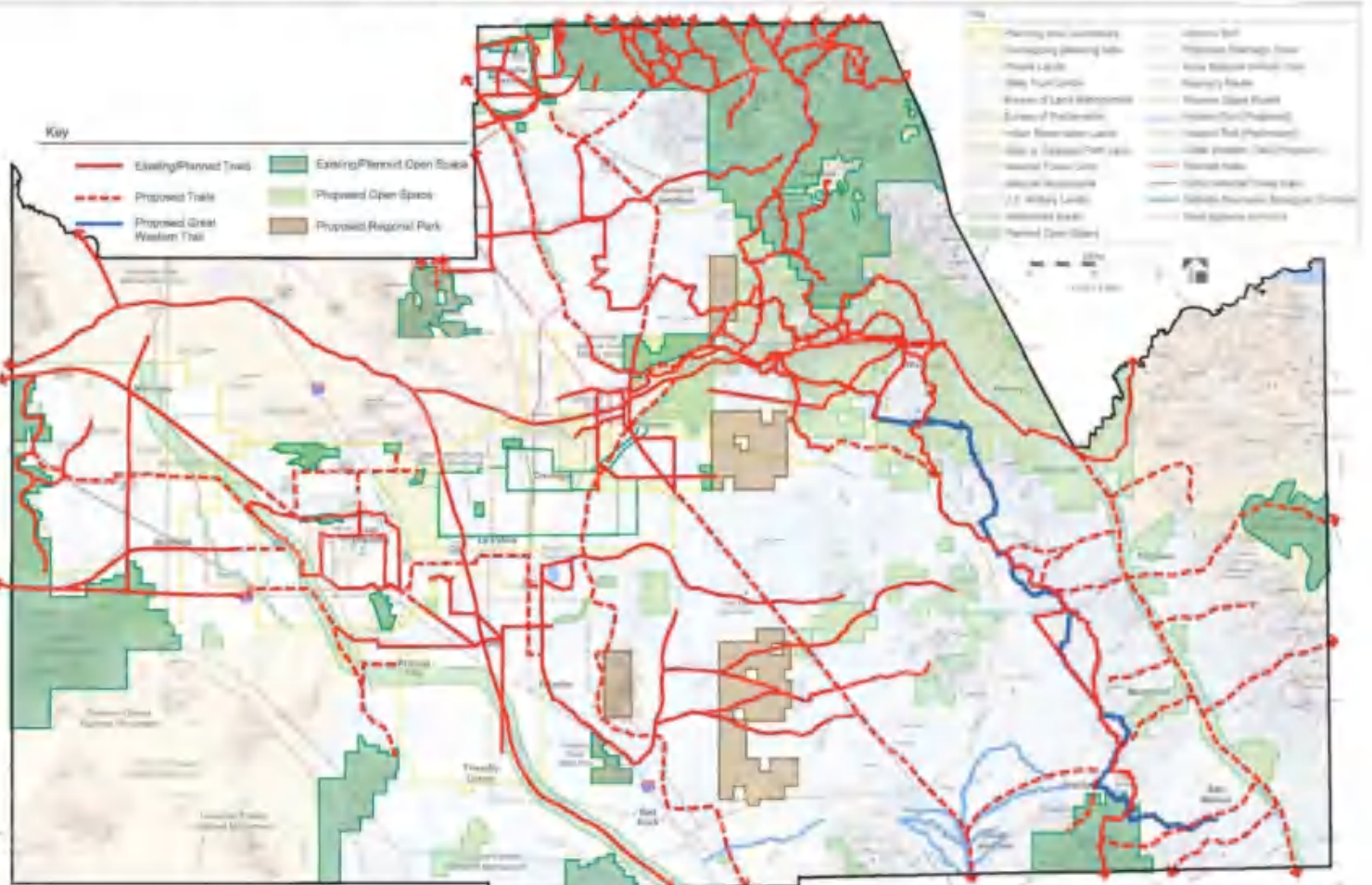

Map of option 2 of the proposed trail network (solid lines: existing trails, dashed lines: new trails)

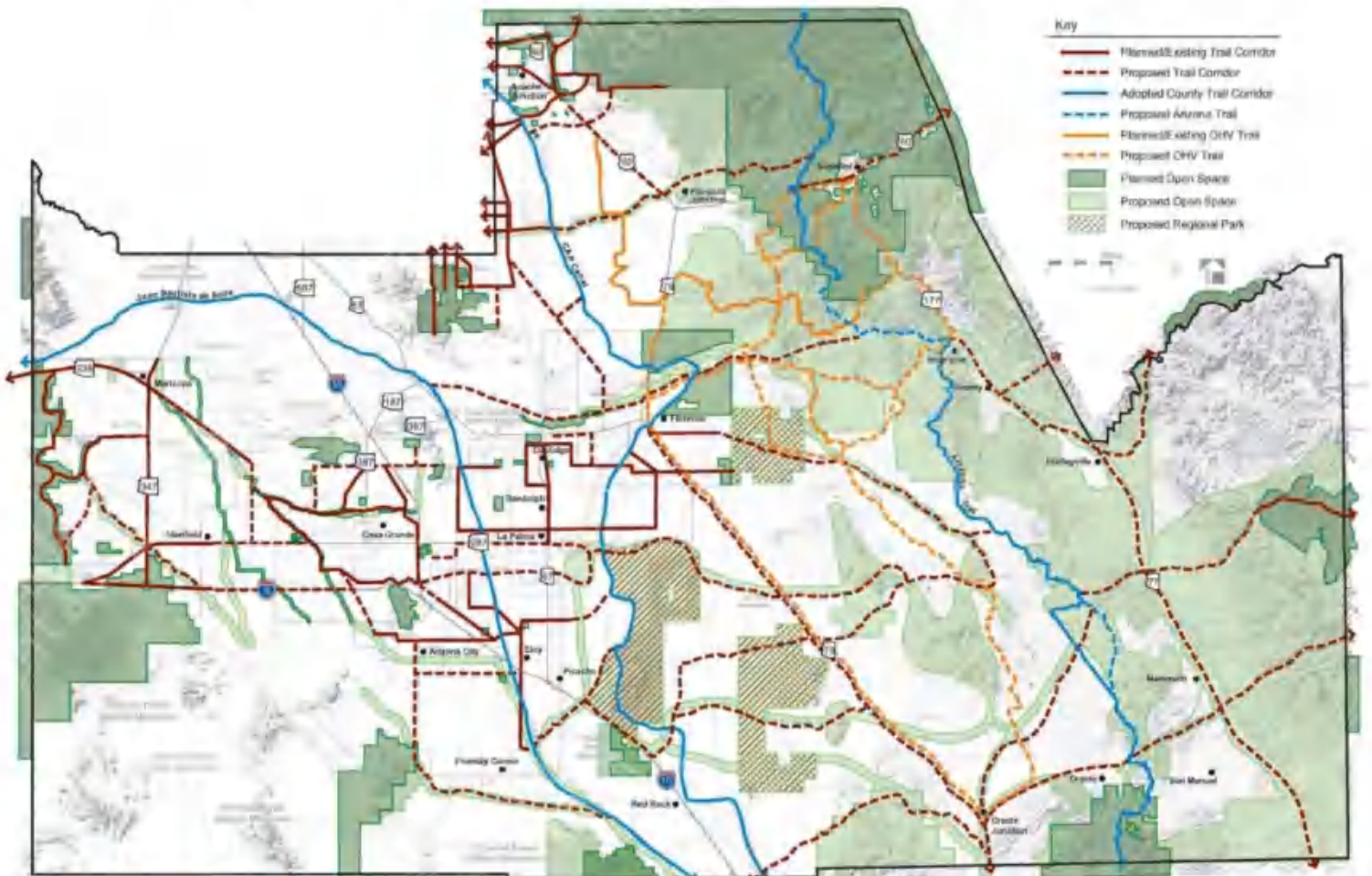



KEY POINTS TO REMEMBER

What makes a good master plan?

Clearly presented context

Land and resource assessment

Maps and plans

Definition of the project and its objectives

Risk and opportunity analysis

Clearly defined targets and offer

Budget, financing plan and estimated schedule

Demand assessment

Operating prospects

DESIGN YOUR TRAILS IN DETAIL

6

Based on the master plan bringing together the answers to the previous questions, the next step is to finalize the detailed design of the trails so that they can be implemented with a high-quality standard.

This "guide" does not enter into architectural plans for each element of the trail, but it lists them and gives their main outlines.

CHAPTER SUMMARY

- 6.1 Questions for guidance
- 6.2 Key technical data for the trails
- 6.3 Supplementary works to plan
- 6.4 Trail infrastructures
- 6.5 Safety and environmental issues
- 6.6 Access and related services issues
- 6.7 Technical analysis and design of trail furniture
- 6.8 Final points of preparation
- 6.9 Final reporting before execution of work
- 6.10 Specific case of interpretation and educational trails

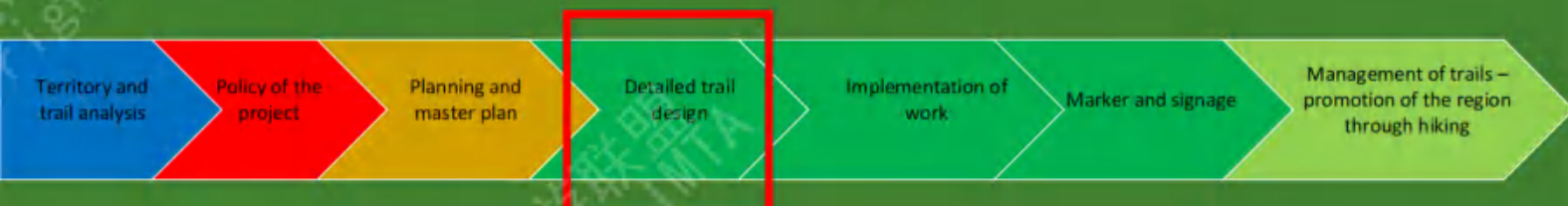



© Serge Koenig: location of trails within the framework of the Alpes-Sichuan cooperation (China 2013)



6.1 - Questions for guidance

- Are you clear on your choices of routes or crossroads network? With looped trails? For linear trails? Why? (refer to: P2 - Chapter 8)
- Have you marked out the routes with ground markings or markers before construction work?
 - o Confirm one last time with the departures and destinations of the trails designed;
 - o Confirm that the routes are logical, on varied trails and on stable soils;
 - o Check the judicious integration of the existing trails presented in the plans;
 - o Check that the routes are adapted to the surface reliefs and natural structures of the land;
 - o Adapt the inclinations of the travel slopes according to the future users and the environments crossed;
 - o Avoid unnecessary climbs and descents;
 - o Avoid direct sections in the slope line;
 - o Avoid risky places, areas of livestock grazing, natural habitats for protected fauna, swampy areas;
 - o Consider the trails' compatibility with the landscape and protected sites;
 - o Validate a final marking before construction.
- Have you clarified the needs for infrastructures (bridges, suspended paths)? Where are they needed?
- Have you detailed all the areas on the routes where you need to improve, stabilize, secure or build?
 - o Explore options for crossing streams, ravines and ditches;
 - o Evaluate the advisability of installing stairs and ladders on certain steep sections;
 - o Evaluate the safety facilities of areas with increased risk of slipping or falling, e.g. guardrails and handrails;
 - o Evaluate the construction work done to stabilize embankments and unstable slopes;
 - o Have you taken into account the construction standards or upgrading of walking areas, rainwater diversions, and excavation/backfill work?
 - o Plan for rest areas, picnic areas, viewing points, etc...
- Are there construction materials available on site (wood, stone, and gravel)?
- Are there any specific trail building permits required?
 - o Make sure that you have taken all these legal and environmental issues into account.
- Will it be necessary to take special measures for the safety of workers and passers-by during the construction phase?
- Will special measures be taken to protect the environment during the construction phase? (refer to : P1 - Chapter 12)
- Have you clarified the needs for materials and construction equipment and machinery?
 - o List the tools and machinery;
 - o Evaluate the duration of use and the rental costs.

- **Have you assessed the man power and skills required for construction?**
 - o Identify the work that can be done by volunteers, clubs, etc.;
 - o Identify the professional supervision of volunteer groups;
 - o Identify the work reserved for specialized companies;
 - o Request quotes and initiate calls for tenders if necessary.

- **Have you clarified all liability and insurance issues?**
 - o Insure the volunteer workers;
 - o Take out civil liability insurance;
 - o Take out civil engineering construction insurance.

- **Have you identified the transport routes for materials and tools for the construction?**
 - o Explore all the options: carried by man or animal, by vehicle, cable-car, or helicopter;
 - o Evaluate the cost.

- **Have you refined the elements to update the estimated budget of the master plan?**
 - o Include all the costs involved, including those related to the development of hikers markings and signage; (refer to: P2 - Chapter 8)

- **Have you identified all related facilities and services?**
 - o Get a clear idea of these components:
 - What is generally the responsibility of the manager: entrance of car parks with toilets and bins, campsites, shelters, etc.
 - What is the responsibility of private participants around the trails: commercial accommodation center, taxis, guides, etc.

- **Have you gathered all of the necessary information to write the last technical report which will guide the construction work?**





© Schwäbischer Albverein: a trail covered with wood chips (Germany)

6.2 - Key technical data for the trails

The following technical indications are the backbone of the planning of the construction work for the implementation of the trails in your project, whether they are existing trails to be improved or new trails. All interventions construction on the trails must be detailed and included in the technical report made available to the construction teams.

ESSENTIAL ELEMENTS WHICH MUST APPEAR IN THIS FINAL TECHNICAL REPORT

 **The completion of the route** (the content of Chapter 12 of part P1 is to be referred to as a complementary part to the following content):

The determination of the exact route should make the path as attractive and secure as possible, while keeping construction and maintenance costs at a reasonable level.

The planned route must be as direct, clear and logical as possible, but without long straight sections (monotonous for the user). It must be suited to the natural structures of the land (surface, reliefs), which makes it possible to avoid significant soil digging and transportation.

The existing trail sections must be integrated in a judicious way and considered as historical communication ways. They should be improved and valued as much as possible rather than being changed or destroyed.

The route must be aesthetic and allow users to enjoy at attractive environments.

Generally, we must avoid routes:

- that are too steep or directly situated in the line of maximum slopes gradient (risk of erosion);
- that are on long sloping rocky sections (which will require trail burrowing or metal/wooden structures such as stairs or handrail);
- that are in stone gullies and areas at risk of crumbling (scree corridors and slopes) or landslides (the signs of landslides are cracks in the ground, trees growing inclined in the slope, etc.);
- that are on inappropriate or sensitive grounds (for example, wet, swampy, unstable areas, dry meadows, bird nesting sites, etc.);
- that are in the meadows with cattle;
- Etc.

The trail must respect the environment of sensitive and/or humid areas (refer to: P1 - Chapter 12);

It must be drawn on the field with marking tape or with frequent and visible marks (avoid painting) before construction of the trail;



The width of a trail

- ≤ 100 cm in a classic environment;
- between 50 and 80 cm on steep and rugged ground.

Including the recommended side clearances of the trail of about 10 cm on each side of the walking surface to ensure a safe movement.

The width is only a recommendation and not a rule. It is never strictly constant, and it can be widened in heavily frequented sections to allow side-by-side walking (e.g., when approaching a point of attraction, a stopover, or a viewing point). But in steeper sections, this width may be smaller.

Easy trails are generally wider than challenging trails.



The vertical clearance height of trees above the trail

- 2.5 m to 3 m

Pruning work must be done according to the good rules: cuts in the right places and promoting healing and preservation of healthy trees. Cut brushwood and branches should be dispersed outside the walking surface of the trail to maintain the forest floor and promote regeneration.

This clearance ensures safety and ease for the user, and an open view of the next part of the trail and the landscape.



The lateral inclination of the walking surface

- Between 3% and 5%

The surface of the trail must be laid out in a way that enables drainage and facilitates the flow of water out of the walking surface without disturbing the walker. This inclination is the most favorable for reducing erosion and for maintenance work. If the natural inclination or erosion of the trail is too significant, rehabilitation work should be considered.



The surface of the walking pathway

The walking surface and its width are first and foremost determined by the target audience and attendance.

Generally, the walking surface must be cleared of obstacles or debris such as sharp or unstable stones, stumps, dead branches, etc. The main roots must remain visible and those of small plants must be pulled up (not cut) to avoid regrowth.

On open, dry, and load-bearing ground with a slight slope, the walking surface does not require any special work except for possible cutting of tall grass or brushwood. Such ground allows routes to spare the landscapes and reduce construction costs.

The walking surface should be as natural as possible. The installation of an artificial coating constitutes a significant impact on the hiking network. But natural stone slabs cover can be considered as durable and aesthetic.

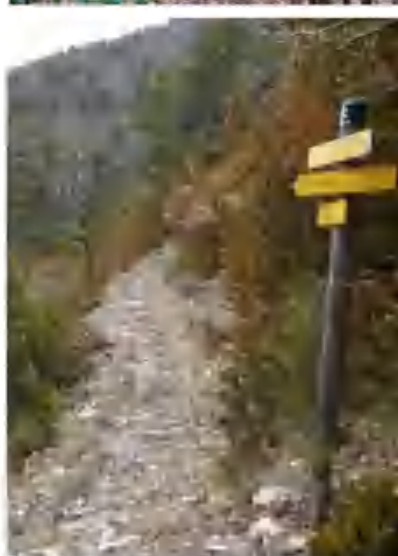

According to the target audience and attendance (walkers, tourists, in large numbers), the stability of the trail and the quality of the soil may nevertheless require foundation formwork (10 to 15 cm deep) on certain sections; the filling and covering materials are then crushed stony aggregates (maximum grain diameter of 60 mm) and gravel. In case of wet or marshy areas, wood chips, that must be replaced regularly, can be used to cover the walking surface. Other special measures may be necessary to improve the bearing capacity, including geotextiles, log or plank paths, or paths on stilts, etc. In all cases, bitumen, tar and concrete should be avoided, as this type of surface can cause premature symptoms of fatigue for the walker and can damage the landscape and have negative impacts on flora and fauna.

On hard and frequently slippery ground, user safety may then require facilities such as a guardrail on the edge. In general, the rule should be to aim to maintain the recreational function, attractiveness, safety, and consistency of the trail network, in particular by means of a surface suitable for a targeted type of hiking activities and hikers.



The stability of the trail must be ensured over its entire length.

The layout of the routes and the choice of the trail sections must take the geophysical characteristics into account, which must be appropriate for the passage: loose or stable soils, rocky soils, soils with good drainage capacity, etc.





© Serge Koenig: avalanche damage on a trail in Chamonix, Alps (France)

6.3 - Supplementary works to plan

The techniques or structures presented below make it possible to stabilize the trail and overcome any problems of accelerated erosion related to various factors such as the attendance, steep slopes, etc. The climate has a considerable influence on their dimensioning: frequent heavy rainfall means increased demands on drainage, on resistance to erosion and on stability of paths and embankments.



Drainage

The main enemy of the trail is water: rainwater that collects on the walking area and water that flows from the slope above the trail. Avoiding the accumulation or permanent runoff of water on the surface of the trail preserves it from erosion and protects the environmental quality of the trail.

The lateral inclination of the walking surface (3 to 5%) is provided for this purpose. A lateral downstream inclination is the most frequent. A lateral upstream inclination is a good idea if there is a risk of users slipping into a ravine, but it requires longitudinal drainage and transverse drainage pipes.

To promote natural drainage and avoid water accumulations, the trail can be traced on the surface reliefs so that it includes frequent slight ascents and descents. Specific adjustments may be necessary if the problem of water accumulation and permanent runoff cannot be resolved naturally.



Surface water drainage pipes

- By ditches oriented parallel to the path, preferably located at the edge of the path, and dug in a "U" shape rather than a "V" shape. These must be stable and durable, and their depth and width are determined according to the composition of the soil, the location of the bedrock, the slope, etc.;
- By water bars which are transverse diversions arranged perpendicular to the trail. To promote flow and self-cleaning, their slope should be about 5% with an angle of 30 to 45 ° to the line of the trail, thus allowing the water to be drained laterally or to cross the trail. The water bars can be made of natural stone, wood, or "U"-shaped metal parts.



The greater the longitudinal slopes of the trail are, and the more frequent heavy rainfall is, the shorter the distances between each water bar must be (varying between 5 m and 60 m). Their cleaning is part of the routine maintenance work.



Excavation and cut/fill

Digging to build a trail should be avoided if natural progression under suitable conditions is possible.

If this work is carried out, prior consultation with the local service in charge of soil protection is necessary; a check is necessary on the absence of pipes (water, gas, electricity, etc.) in the ground; tree felling should be avoided (refer to local regulations); the cleared volume must be distributed and stacked near the trail; the stones can be useful for paving, building up steps or a retaining wall.

Excavation work to pass a trail on a slope is often accompanied by the construction of retaining walls. These are installed downstream to strengthen the foundation of the trail or upstream to prevent the collapse of the dug embankment.

This work will only be considered if the soil allows it and in the following situations:

- If a section of the route crosses a transverse slope with an inclination of more than 5% (this is common in mountainous areas);
- If the route passes through ground depressions which accumulate water and there is no natural possibility to reroute around these zones: in this case, the ground depressions can be filled, and the ground elevations can be smoothed out;

If the work is deep, it is recommended to first clear the upper humus (the layer rich in organic matter) and not to mix it and pile it up with the basement materials. After building up the walking area of the trail, it will be advisable to spread this humus on the surface to allow faster re-vegetation.



Shoring or supporting

If a trail section is at risk of collapsing on the slope or sliding sideways; if the steeply sloping ground does not allow trimming of the trail, then a shoring must be constructed vertically to maintain or to build the walking surface, using wood, stones, metal anchors or other material. During this work, the water drainage issue must be considered and resolved.



Slope

Leading the route directly in the slope line when it is steep can cause discomfort compromised safety and destabilization of the ground due to the repetitive trampling and the rainwater flow.



In addition to the drainage techniques presented above, we can arrange the trail with switchbacks to reduce the slope and build steps and stairs for shorter sections.

An optimal slope for a climbing or descending hiking trail is estimated between 3% and 15%. In steep mountain areas, the slope can go up to 30%.

Beyond 15%, the installation of switchbacks and/or steps will make the use of the trail easier and more stable on the ground. For a slope greater than 40%, the installation of a stair is generally necessary: the top of the stair must be arranged so that the rainwater flows on either side of the stair and not on the steps.



Switchbacks and half-moons

- The layout of the trail in switchbacks allows you to climb in zigzag, with a less steep slope than the direct slope line. The bends should be planned in stable and flat places where the path ideally bypasses boulders or trees. In the bends, it is also possible to facilitate the ascent and descent by the construction of a few steps. The downward inclination of the steps towards the outside of the switchbacks promotes the rainwater flow. The sections between the bends must also be of different lengths to allow the water to be diverted in the turns so that it is not evacuated towards the switchbacks located just downstream where an accumulation of water could cause erosion damage;
- The layout of half-moon trails consists of following the surface reliefs of the land with +/- large curves allowing people to climb a hilly slope in a roundabout way and with less effort.



Embankment steps and stair

As indicated above, steps and stairs have the advantage on the one hand of making it easier for users to progress in steep escarpments (above 15% depending on the soil) and on the other hand of retaining the soil by preventing erosion.

In long stairs, a flat landing of a few meters should be planned every 10 to 15 steps for the comfort of users, to vary the walking pace and reduce the risk of erosion. It is not advisable to set up an isolated single step because users not paying attention could stumble if they do not see it.

This construction work consists of:

- Steps in the ground built of stone or wood (possibly filled with gravel depending on the type of path and users). Their profile can range from the classic 20x25 cm steps to 15x50 cm long steps with backfill (these dimensions are only for reference);
- Raised wooden or metal stairs above the floor;



- Metal ladders installed to cross vertical passages where walking is impossible.

These must be maintained regularly.



In rocky terrain

The planning and construction of paths in rocky terrain must always be entrusted to specialized companies. Construction work in rocky terrain is very demanding and expensive, as it involves the use of special machines and techniques (compressors, jackhammers, mining work). It is often necessary to build complex engineering structures, such as pedestrian bridges, stairs, or ladders. The reduction in accessibility and the implementation of specific safety measures also contribute to increasing the cost of the work.

Materials

Facilities and infrastructure can be built in stone and wood. If natural materials are not available, they can be replaced by metal and synthetic materials. The stone and wood used should ideally be locally sourced if available; a quick and less expensive option.

Stone is the priority material if it is found in abundance in the field. A well-designed stone layout will be permanent and sturdy, but this type of construction requires more labor.

Wood will be preferred if the land does not provide enough stones. The use of healthy, untreated, durable and debarked wood is preferred, such as cedar (because of its strength and durability) or white pine and hemlock (known for their strength and rigidity).

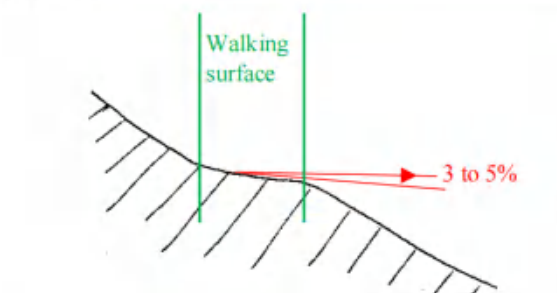
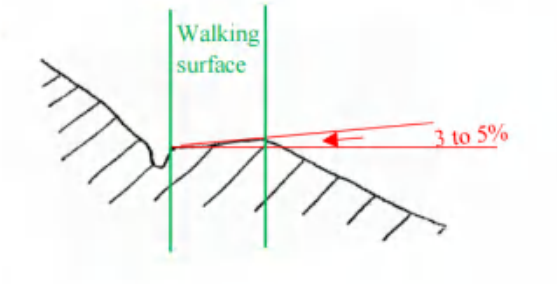
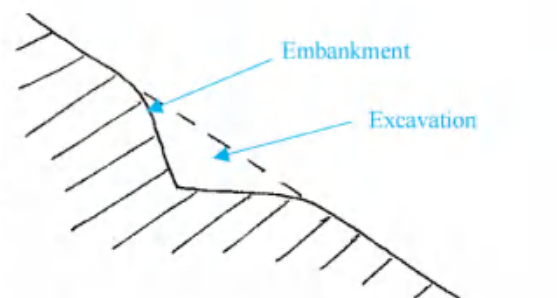
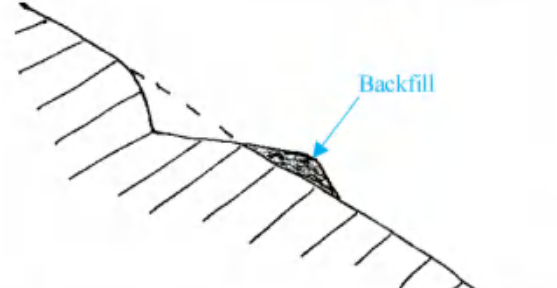
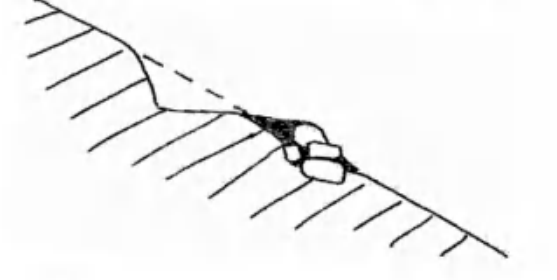
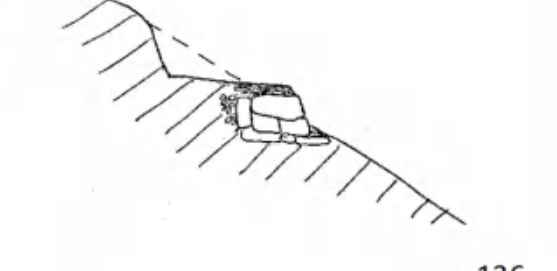

TABLE: some fundamentals of trail shaping

<p>Trail: section 1</p>	<p>Lateral downstream drainage slope, 3 to 5% inclination</p>	
<p>Trail: section 2</p>	<p>Lateral upstream drainage slope, 3 to 5% inclination With a longitudinal drainage pipe</p>	
<p>Trail: section 3</p>	<p>With clearing work on the slope</p>	
<p>Trail: section 4</p>	<p>With clearing work and downstream backfilling to reinforce the stability of the trail (shaped with the excavated material)</p>	
<p>Trail: section 5</p>	<p>With clearing work and backfill reinforced by a stone border (shaped with stones from the ground and excavated materials)</p>	
<p>Trail: section 6</p>	<p>With clearing work on the retaining wall (shaped with stones from the ground and excavated materials) becoming the walking surface</p>	



© Serge Koenig: construction of the pedestrian bridge of the Jinji Gu to Pingle trail within the framework of the Alps-Sichuan cooperation (China 2010)

6.4 - Trail infrastructures

These are bridges, suspended walkways, stairs, handrails, retaining walls, etc. whose function is to facilitate walking and to secure the user and sometimes also the environment.

Before considering their construction, the designer-planner must first assess all the possible solutions to naturally bypass the obstacle and choose the one that can provide the best safety/environmental conservation ratio.

Design criteria

Is this facility necessary? What does it bring? These are the questions you need to answer. These constructions should only be undertaken for practical and necessary purposes, to meet the needs of security, stability, and environmental protection.

For the sake of uniformity and consistency, the facilities on the same trail must be manufactured in a unified manner, use the same type of material and the same design, and be as harmonious as possible with the natural environment. In general, the more facilities there are, the more artificial the trail becomes, and the more it deviates from the "hiking spirit", also making it more expensive it is to build and maintain.

Whatever the scale of these infrastructures, they must be designed according to the country's regulations for constructions of public use, with low impact while being durable, accessible, stable, and safe.

Infrastructures: hanging bridge, single-arch bridge, and footbridge

These are good ways to cross a watercourse, a wet space, or a strong low-lying area of the surface relief. To span a watercourse, the dimension of the bridge is decided by the type of users and the expected attendance. The local climate (frequency and intensity of rains, floods, etc.) must be considered: the height and size must be calculated according to the maximum water flows. Their location is chosen according to the width (as short as possible) of the ditch or the watercourse and the appropriate places for the construction of the bridge supports.

If fording a stream is possible (crossing in very shallow water), it should be favored.

If fording is not possible or presents potential dangers for the user, an arrangement will be necessary allowing free movement of the water.



This could range from “stone steps” stabilized in the ground, to heavier constructions to link both riverbanks. According to the scope of the construction work and the infrastructure, an authorization from the responsible public services will be required with skilled workers: design office and builder. It is therefore important to anticipate this construction work in the planning phase.

The ideal construction material for structures on a walking trail is wood (depending on its availability), both for the supporting structure and the walking surface. The walking surface can be made by logs or planks, potentially covered with earth or flat stones to make it less slippery.





© Serge Koenig: edelweiss from the Himalayan pastures (China, 2016)



© Serge Koenig / Alpes-Sichuan Collection: creation of a trail and a via ferrata in Pingle, Chengdu (China 2009)



© Serge Koenig: location by the Alpes-Sichuan cooperation on local trails in Qionia, Longmenshan (China)

6.5 - Safety and environmental issues



In case of emergency and rescue

Recreational or tourist trails, regardless of their length, must incorporate regular entry/exit points from the route and connect to inhabited areas or roads communication. This is to allow users to escape and rescuers to intervene if necessary.

No point on the trail should be more than one day's walk away from the nearest emergency response service. On more isolated and busy trails, the developer can build shelters or emergency cabins for users in difficulty.

During planning, the liability of trail managers and developers must be analyzed in the light of local laws.



Level of difficulty announced

At all points of departure or access to the trail, the level of difficulty of the trail (refer to: P1 - Chapter 9) and the risks must be mentioned on an information panel in order to advise the hiker. If a trail might be dangerous, it is better to close it and not to encourage the public walk on it.



Crossing watercourses

See above



Integrity of the banks of watercourses and water bodies

The trampling of the ground and the frequent attendance of the surroundings accelerate the erosion of the banks. Even lightweight structures that cross a watercourse or a water body, are located on the banks. The developer must make sure not to damage the banks or shores.



General protection

The trails must be safe in all aspects.

- Maintenance and pruning work must ensure that there are no sharp branches at breast height in the walking axis, no dead trees threatening to fall on the trail...



- According to the degree of difficulty, ramps/handrails/safety cables or guardrails (in wood or galvanized metal) solidly anchored in the ground or rocks are strongly recommended for sections of trail where there is a danger of falling. The models of these installations are very diverse and can range from a simple cable fixed on pitons in the rocks, to more sophisticated balustrades. These installations can also be found on hanging bridges, bridges, stairs, belvederes, viewing points, etc. The dimensioning of these facilities must take into account the types of users and the expected attendance. Their conception and implantation require specific skills and using the help of professionals is strongly recommended;
- If the trail crosses under an area of rocks that have become unstable and could collapse (for example, due to heavy rains or an earthquake), this section can either be rerouted to bypass the dangerous area, or the sections of unstable soil can be secured and reinforced with wire netting. Another option is to close the trail.



Use of dangerous products

- The use of dangerous and potentially toxic products for the environment such as herbicides to control vegetation or insecticides to get rid of insects, must be prohibited;
- The use of machinery or motorized equipment can be a potential source of contamination. Very strict measures must be taken to minimize the risk of accidental oil spills when using tools or motor vehicles in the course of service.



Environmental impacts

The imperatives of preserving the environment must govern all the developments of hiking trails. In principle, the necessary authorizations and permits obtained from various partners and public authorities related to the project during the planning phase, must ensure the compliance of plans and avoid potential problems and misunderstandings.





© Armand Ducornet hostel for hikers along trails in St. Wilhelmer in the Black Forest (Germany)



© Serge Koenig: accommodation for hikers and tourists in Hetch Hetchy, Yosemite (USA 2017)

6.6 - Access and related service issues

A walking trail must provide services that meet the various needs of users.

- For trails for local use, most of the service facilities are optional. However, they often contribute to the quality of a trail and the hiking offer;
- For trails with more tourist uses and longer hikes, the developer will consider facilitating access to certain basic services such as accommodation, water supply and others, thus improving the quality of the overall offer.



Entry and reception point for the trail

For various safety and visibility reasons, each trail entrance must be indicated by a main reception point with the signage of its entrance. The type of these reception points varies according to the nature of the trail offering, the management model, and the safety and visibility needs of the trails. This reception point can range from a simple sign with the name of the trail, to facilities with maps, information, and photos, and even a kiosk with a facilitator.

The space at the reception point may also have dry toilets and garbage cans available to users before they begin their hike.



Registration

Registrations for hikers (self-registration, registration at reception, by phone, on the Internet, etc.) is sometimes required for safety and environmental reasons. This registration is desirable in the case of long hiking trails, involving high accident risks, or taking place in sensitive natural environments. The accompaniment by professional guides is also, in this case, a guarantee of compliance with safety and eco-responsible rules.



Parking

Car parks may be set up at the trail departure area, along the access roads or near intermediate entry points. These parking spaces must be on a scale suitable for the frequency of use, and they are essential for organizational and safety reasons at the entrance to high-traffic trails. They must be easily accessible and without public nuisance for the neighborhood or the environment.



Various service points

Services that meet essential needs during long hikes (room and board) must be located at regular distances on the trail according to its degree of difficulty. Regardless of the hiker's position, services should be accessible within a day's walk.



Water supply

In order to avoid the risk of dehydration for walkers on long-distance hiking trails, at least one water point must be accessible per day: water wells, sources of drinking water, selling points, etc.



Rest and picnic areas

Areas for "breaks" during the hike can be set up at regular intervals along the trail. These can be equipped with fixed tables or simply benches. They can even offer a roof shelter with gazebos.



Toilets and garbage cans

They can be conveniently installed at the start of the trail, at the exit of the trail, at the various intermediate entry points of the trail, and at the different accommodation locations (where they are easily accessible for emptying and maintenance). The trail itself does not include any toilets and garbage cans.



No garbage cans along the trails

There are several reasons for the total absence of the installation of garbage cans on hiking trails in the middle of nature:

- They require regular garbage collection, cleaning and maintenance;
- Few of them are accessible by drivable paths;
- Garbage cans induce the user to throw their waste away, and this gesture is pedagogically the opposite of the eco-responsible behavior to be inculcated: that everyone must bring their waste with them;
- Garbage cans and waste attract animals which will scatter it in nature;
- Etc.

How to go to the toilet in nature

This rule should be promoted among users, in particular for cruise hikes:

- Human waste must be buried in the ground at a minimum depth of 15 cm and covered with soil;
- The place must be at least:
 - o 100 m from any watercourse and water body,
 - o 100 m from the bivouac camp areas and trails.



Accommodation on or near the trails

This service applies mainly to long-distance hiking trails because users will be spending the night in the field. At least one accommodation point must be accessible on each day of the hike. These types of accommodation facilities include camping sites, refuges, "lean-to", and shelters. A short hiking trail does not exclude the provision of such a service, but it is not mandatory.

- Self-contained camping sites (generally organized in the middle of nature). These are bivouacs in the wilderness, designed to accommodate hikers with their own equipment. These camping sites should be in a discreet location, away from trail intersections or busy sections, and ideally only accessible by hiking. It must also include good geophysical conditions to ensure soil stability and good drainage (a slope of 2% to 5% is favorable). Each site must be well delimited, sufficiently large, comfortable, safe, and isolated from neighboring campsites.

Other arrangements that must accompany even a basic camping site include: a water point, a dry toilet as well as a fire pit and a supply of dry wood (if local regulations allow it).

If the camping site is located near a watercourse, no tent should be set up within 30m from the water to reduce the risk of damaging the banks.

Pit type dry toilets with shelter must be built near the camping site and any other makeshift accommodation (shelter, refuge, etc.). Toilets must be installed more than 100 m from a water body or a watercourse.

To heat food, the use of a camping cooker is preferred. The possibility to build campfires may be limited depending on local regulations, current conditions, and risks of fire. Outdoor fireplaces such as metal basin or open fieldstone can be fitted for this purpose. An external supply of firewood should be preferred to wild collection of dry wood. Any cutting of wood must be prohibited. A behavior charter on respect for the environment, the use of water, toilets, wood, waste, and ash, etc. must be carefully drafted, and known and respected by users.



- Refuge, "lean-to" and shelter
 - o These shelters are basic dwellings with dormitories and a kitchen corner, allowing hikers to spend the night there;
 - o The "lean-to" and other shelters are open huts without doors and with a roof sloping backwards, under which users can rest and sleep sheltered from bad weather.

The manager must ensure the monitoring and maintenance of these various infrastructures located in the middle of nature, due to the risk of vandalism, fire, or encroachment. These infrastructures must all be equipped with a fire extinguisher and a sweeping and cleaning kit available to passing users.



Open shelters for nature hikers on the trails of Denmark

Refuge

The initial concept of the refuge was to be without guardian, open and free to any passing hikers, who could even use certain paid services: use firewood, bottled drinks, gas, blankets, etc., and would then deposit the money for the services used in a collection box. This principle was based on honesty and trust.

The explosion of tourism, the changes in attendance and mentalities, have almost completely wiped out this beautiful concept.

Today, very few refuges are still unguarded and open. The guards now offer catering and a +/- simple hostel service during peak season, while also acting as intermediaries to prevent emergency services in the event of an outdoor accident. These shelters are supplied by drivable paths or by helicopters. They are closed in the off season, with metal doors and shutters.

- Commercial accommodation center for hikers
These are guarded and operated shelters, farms, inns, outdoor centers, developed campsites, homestays, etc. Users make good use of these services when the trail passes near these sites or near the villages. Hence, there is no extra maintenance or effort for the trail manager. If they are easily accessible, it also stimulates the development of the local economy.

Widespread accommodation on the immediate perimeter of the hike is important in the design of itinerant excursion trails.



Additional commercial services for hikers

Manager can also set up services (by himself or delegated to entrusted partners) that will improve the quality of the experience of a hike or a hiking trip:

- Shuttle service (regular service or by reservation) between one parking lot and another, or from a departure point to a distant arrival point;
- Luggage transport between accommodation points (particularly popular for cruise hikes);
- Equipment rental (backpack, tent, stove, lamps, etc.) and sale of products (emergency call whistles, freeze-dried food, guidebooks, etc.);
- Hiking guide or interpreter;
- "++ Hiking" experiences with botanists, photographers, historians, singers, etc., or with packsaddle donkeys etc.

All these related services will be gradually set up by the local project partners, hosts, transporters, guides, clubs, etc., who will react more effectively if the number of visitors is high. The project leader must have a clear vision of all these trades and services that can be developed around his trails project.

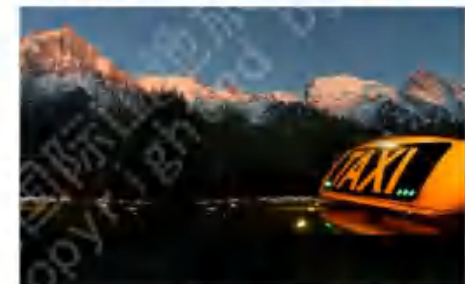



6.7 - Technical analysis and design of trail furniture

For this part of the project, you have to work with a professional design office to draw up a plan for each element of the trails, including the furniture such information panels and signs, that will punctuate the trails, for their manufacture and installation along the route.

Tables and information boards at the entrance to the trails and on remarkable points of interest, directional arrows on crossroads, and markers scattered along the trails, are structuring elements for the development of a network of quality hiking trails. The same goes for themed, and interpretive trails, which are much more equipped with educational, leisure and interactive facilities.

How can you equip your trails to make them as accessible as possible for the target hikers, while maintaining their natural characteristics?

To do this you must:



Define a marking and signage system for your trails ([refer to: P2 - Chapter 8](#)). The same system must be respected on all your trails to ensure the comfort and safety of users (a changing system can cause confusion and makes communication with the users more complicated). Moreover, there will only be advantages if the same system is adopted on the other trails in the same region;



Choose the design of the facilities which can convey information, and choose the supports fix them on the ground. For the consistency and aesthetics of your hiking offer, the design must be well integrated into the environment of the trails. It must be the same on all the routes that make up your offer. But contrary to the system of marking and signage which it is advisable to extend uniformly to neighboring cities, the design of the facility supports, and furniture can be specific to your trails in order to enhance the differentiation of your offer compared to that of the other offers nearby;



Choose to use wood, galvanized steel, or synthetic material (lifespan greater than 10 years). It will be appropriate to have the same materials and the same style of manufacture and construction for all the furniture, facilities, and structures (small bridges, rest areas, picnic tables, panoramic terrace, etc.) on your trails.

It will be necessary to choose the right professional supplier to carry out the design study and manufacturing (and even installation). Some suppliers can be good partners integrated into the steering/reference group of your project to participate in the reflection and programming phases.

FOR EXAMPLE: elements of a technical study of trails furniture

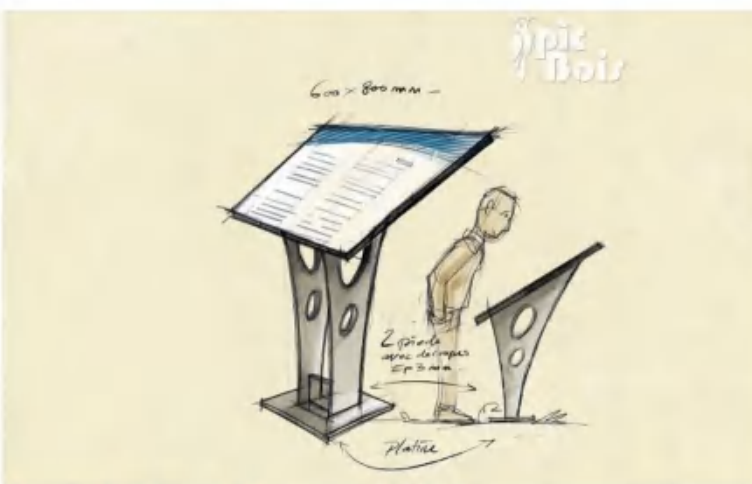
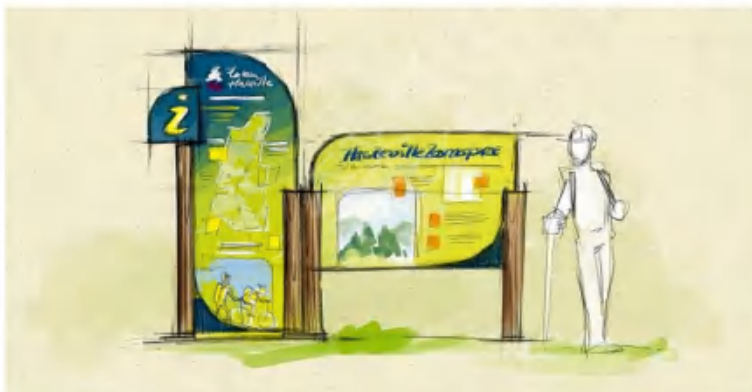
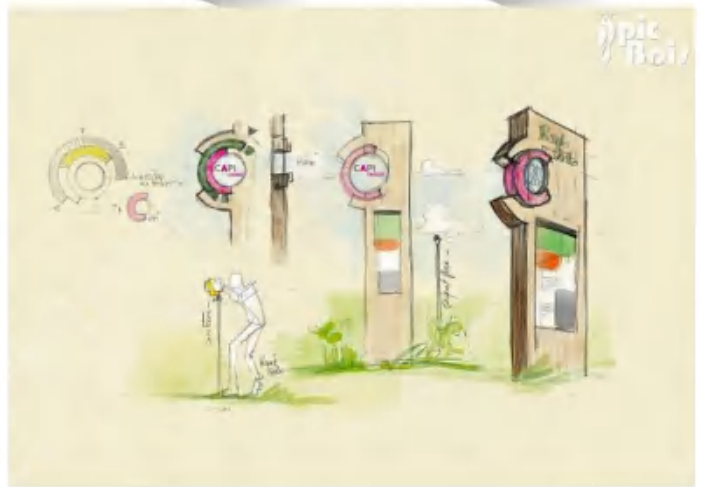
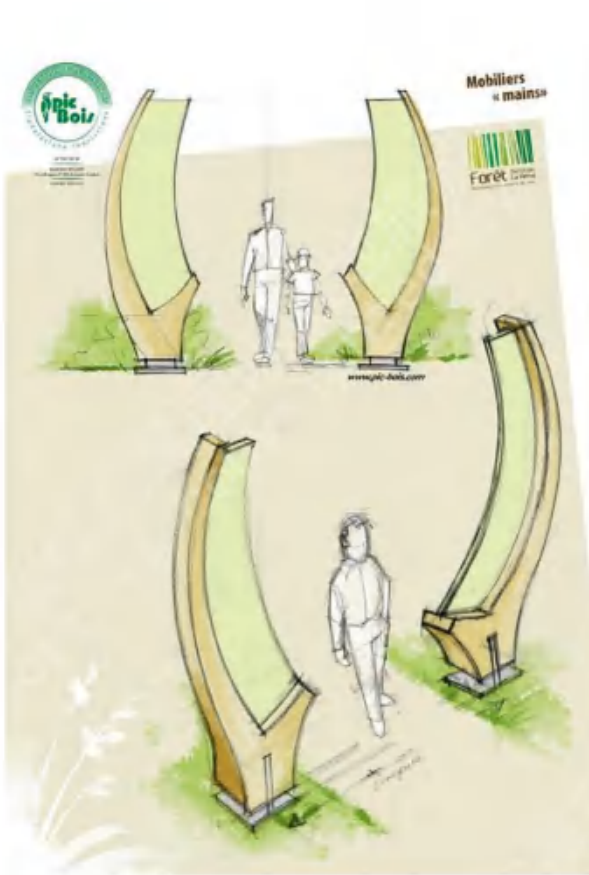

FOR EXAMPLE: graphic design elements

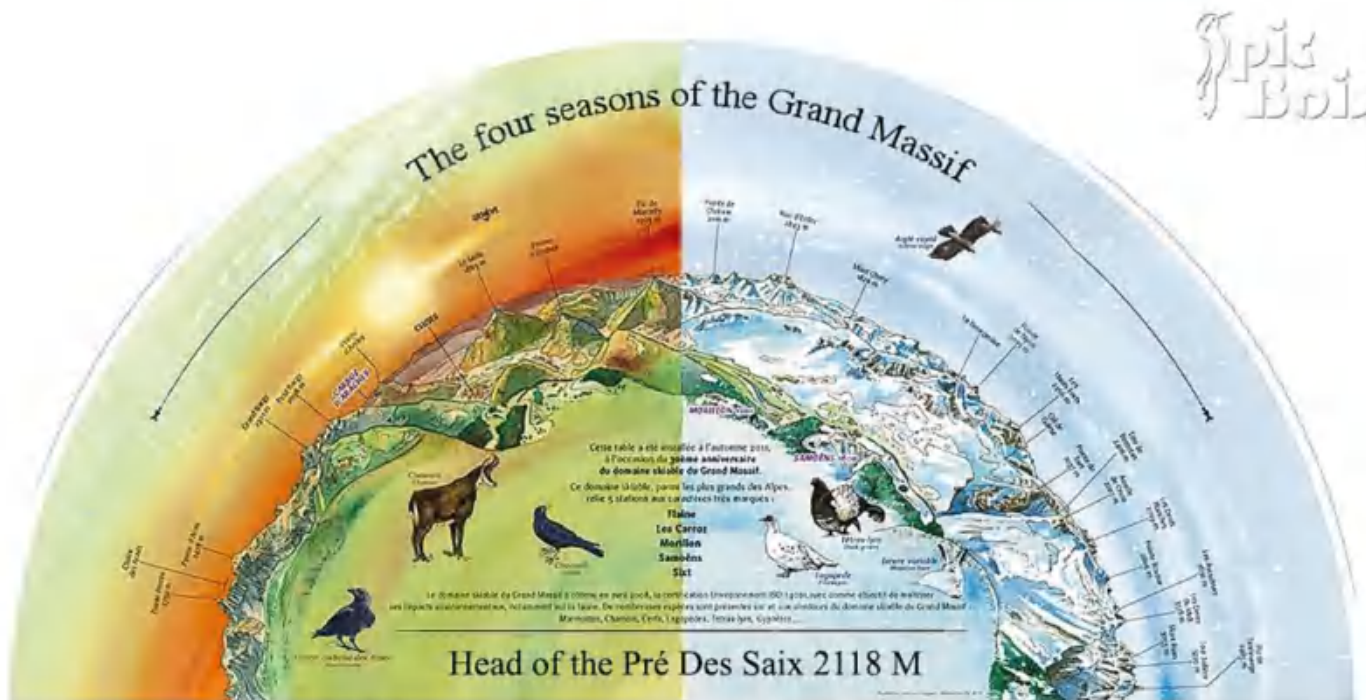

FOR EXAMPLE: various types of installations on the trails



[Source: French design office www.pic-bois.com]

Marking and signage

See CHAPTER 8 – PART 2







© Schwäbischer Albverein, use of mechanized equipment to cover trail with wood chips (Germany)



© Serge Koenig, use of horses for paving the trail from Jinji Gu to Pingle, Chengdu (China 2009)

6.8 - Final points of preparation



Preparation of the trail construction work

Before the start of the work, it is preferable to check the layout one last time and to finalize the necessary markings on the field. At this time, it is still possible to make minimal adjustments and to take into account the wishes expressed, for example, by landowners.

The execution of major construction works, in particular heavy engineering structures (hanging bridges, pedestrian bridges, stairway) must be entrusted to a construction company. The latter will be responsible for the workers, machines, devices, tools, and materials and for complying with safety requirements. It must adhere to the agreed deadlines and carry out warranty work in the event of poor performance.

The intervention of auxiliaries (e.g., military, civil defense, school classes, and volunteers) is very beneficial from various points of view. This participation of different actors in the construction work promotes the appropriation of the community for the trails, while also helping to reduce costs. However, it requires more preparation on the part of the project owner: it is necessary to organize the tools, take care of meals, transport and accommodation and ensure the permanent presence of competent professionals for monitoring and management of the work on site. Certain framework conditions may be applicable to the intervention of auxiliaries:

- No work in dangerous areas (risk of falling or risk of falling rocks);
- No execution of hazardous work (blasting, using chainsaws or brush cutters etc.) by untrained personnel;
- One professional per each group of ten auxiliary people.



Listing of machines, devices, and tools

The use of construction machinery often allows work to be carried out more efficiently than if done manually. The following check-up questions are used to determine whether it makes sense to use machines:

- Is the land accessible for machines? From where? The passage of machines must not leave visible damage;
- Is the area suitable for the use of machines? Very steep terrain often makes it impossible to use machines. The lack of space, for example, in the forest, is a determining factor in the choice of machines as these must not do any damage to the trees;
- Does the construction work justify the use of machines? The use of machines is unwise for paths with a width of less than 1m;
- Among the machines that can be used are those for excavation, compaction, off-road transport, felling, pruning, and trimming of trees, and all hand tools.

- Is the use of machines advantageous (economically, physically, in terms of time) in relation to the efforts required: transport of machines, safety measures, etc.?
- Should we expect conflicts with forestry, agriculture, pastoralists, etc.?
- Should we expect conflicts with the protection of nature and the landscape, or soil protection or protection against noise? In case of poor bearing capacity of the soil, the use of machinery can cause disproportionate damage.



Safety at trails construction work and protection of third parties

The planning of safety measures for workers and passers-by on the site must be done before the start of the construction work. You must check the local regulations that govern this issue and apply them:

- Chainsaw work should only be performed by trained professionals. In the event of forestry work, the access to the site must be blocked over a large perimeter;
- Work sites on sloping ground must be secured against falling rocks. It is customary to use metal wire safety nets. Special safety measures are necessary for all construction work presenting a risk of falling;
- Access to the risk area must be prohibited in order to protect walkers. The risk area includes the site itself and in certain cases the transport roads and, in the event of a risk of rockfall, the downstream paths. The following measures must be taken:
 - Block off the hiking trails concerned on both sides of the risk area;
 - Provide information at the starting points of the hiking routes concerned (temporarily cover destinations on panels with a covering);
 - Point out the bypass
 - Inform the municipalities, tourist organizations, hiking trail organizations, trail services and landowners.



Finalization of the estimated budget

The cost can be estimated based on indicative values. However, construction costs may vary considerably according to the topographical situation and their transport costs, it is therefore necessary that any detailed estimate be established based on concrete offers. In any case, the means of transport (vehicle, cable car, on foot, by helicopter) must be identified and studied.



Finalization of the construction work schedule

This schedule should consider the following factors: funding resources, personnel resources, season, altitude, weather conditions, field conditions, operation of agricultural sites, etc.





6.9 - Final reporting before execution of work

All the detailed and calibrated technical elements directly related to the construction of the trails must constitute a technical report intended to guide the construction work. The summary can be as follows:

- Reminder of the initial situation:
 - o Goal;
 - o Statement of problems, justification of needs;
 - o Project manager;
 - o Property agreements, easements, rights of way;
 - o Registration in a local or regional strategic plan;
 - o Relationship with other projects.
- Topographic situation:
 - o Topographic surveys;
 - o Field conditions;
 - o Sensitive areas.
- Description of the work to be carried out:
 - o Technical characteristics;
 - Table with data (key figures): total length, path width, amount of earth materials to dig (cubage), etc.
 - o Layout:
 - Location plan with existing and planned trail network;
 - Risky places;
 - Inventoried sites and protected areas;
 - Signaling (refer to: P2 - Chapter 8).
 - o Profile types:
 - Cross-sectional sketch of the layout to reveal its structure.
 - o Water diversion
 - Description of the measures to be taken for the drainage of coverings and embankments.
 - o Infrastructures:
 - Description of possible infrastructures with plans.
 - o Cost estimate:
 - Estimate of construction costs.
 - o Safety and environmental protection measures:
 - Possible measures to be taken to protect workers, passers-by and the environment during the construction phase.
 - o Schedule:
 - Table showing the schedule of the different stages of the construction work: at least indicating the start and end date.



© Varennes-Vauzelles City: the discovery trail inaugurated in 2020 with workshops for children (France)



© Varennes-Vauzelles City: the discovery trail inaugurated in 2020 with a 2km family walk (France)

6.10 – Specific case of interpretation and educational trails

As a reminder, the purpose of discovery trails is to arouse the curiosity of walkers, make them ask questions about what they see, and to provide answers to these questions (refer to: P1 - Chapter 8). In the field, the discovery translates into a complete and concrete service intended for audiences whose profile is more like visiting walkers than hikers. Here are the specificities:

- For what purpose? Creating a trail with entertainment facilities, which showcases the natural (flora, fauna, geology, etc.), cultural (buildings, history, etc.) and human (activity, legends, etc.) heritage of the area. It is about using a whole range of media, potentially participatory, to create a relation with the visitor and to bring to life the emotion and the imagination not only through sight, but also through touch, smell, and hearing;
- For what audiences? The classic tourists, amateur hikers, families, seniors (concerning a few segments of hikers). Their expectations are the pleasure of a gentle walk, of discovering, of learning, and of understanding;
- What stages of implementation? The process is the same as for any trail project: a thoughtful process leading from the idea to the project, with the planning, design and implementation phases;
- The key choices: What themes do you want to develop? By what means of communication? According to what scenario?
- In what situation is this concept of trails suitable?
 - o It is a complementary product to the hiking trails of a community network, beneficial to the local population: a way to attract different users and tourist segments with the aim of strengthening the economy;
 - o It is a suitable product for sites with high tourist traffic (holiday resorts, mountain resorts, natural parks, etc.) making it possible to channel and manage visitor flows while presenting the natural environment. This is a way of enabling them to enter the environment without venturing on hiking trails in the middle of the wilderness for those who do not wish to take risks;
 - o It is a suitable product for the diversification of winter activities and to enable continued operation in all seasons of a ski resort;
 - o It is a product that can be based on existing equipment such as park houses, eco-museums, cultural or archaeological parks, etc. offering visitors the opportunity to deepen their discoveries during a fun walk;
 - o It is a product suitable for commercial use.
- On what scale is the work? The recommended duration of the trail should not exceed 1.5 hours, because beyond this duration, the audience is less receptive. It equates to a route of a trail distance of 3 to 4 km maximum.

- Who are the promoters for this type of project? A municipality or an association of municipalities, a state agency, a private owner or lessor... depending on the type of land, public or private, protected or not, etc.
- What are the specific developments?
 - o Attractive communication supports: instructive and informative;
 - o A comfortable walking area (natural or constructed), of a width to enable people to walk side by side, with landscaping, rest and picnic areas, garbage cans and toilets, and if necessary, with pedestrian bridges, stairs, handrails, protective barriers, etc.;
 - o Direct and indirect services: canteens and car parks, the entrance gantry with reception panels and possibly a kiosk with or without a facilitator, an entrance counter and a "ticket office", possibilities for guided tours, etc.
- What are the tips for the texts on information panels?
 - o The text is neither a leaflet, nor an administrative circular, nor an extract from a scientific work. The space available for the text is limited so you must be concise and express the essential points: explain what there is to see. Priority should be given to the title to encourage reading or to summarize the information developed on the panel (according to surveys on these trails, the titles of the panels are read by the audience five times more often than the main body of the text).
 - o To make it interesting, the panel should be informative: it should set out specific, concrete facts, numbers, a testimonial, a quote, dates, names, a story, etc. Apart from the style and formatting, the backbone of information boils down to answering the following main questions: who, what, where, how, why?
- What are the rules of information?
 - o One idea per information panel (what are the interpretive panels along the trail);
 - o The theme of the text must relate to a subject that the visitor sees clearly and instantly on the panel;
 - o A first paragraph that is too long discourages the reader (no more than fifteen words);
 - o Formulate a few sentences that speak directly to the visitors;
 - o A blank between paragraphs increases the reading rate;
 - o Using only one typeface in the panel text can increase the readability;
 - o The vocabulary must be simple, attractive and understandable for a family-type audience;
 - o Use photos and drawings to illustrate the text;
 - o The size of the letters and the inclination of the panel must allow several people to read it at the same time while being located 1 or 2m away from the panel;
 - o Messages on the ecological protection of the site must be systematically mentioned to remind the users.
- What are the design requirements? Comfort, maximum safety, interesting theme, good signage. It is better to qualitatively enhance the potential of the site through a small amount of information stations or stopping points. In addition, the maintenance, the renewal of supports and equipment, and the evolution of the concept are important parts to plan in the management of such a trail.
- What is the cost of the construction? This depends on:
 - o The costs of living, materials and labor in each country;
 - o The involvement of the community and volunteers;
 - o The dimension of the site to be planned, the supports for the public, and the materials used. (In Europe, the development cost for a discovery trail is between 100,000 and a few hundred thousand euros.)



KEY POINTS TO REMEMBER

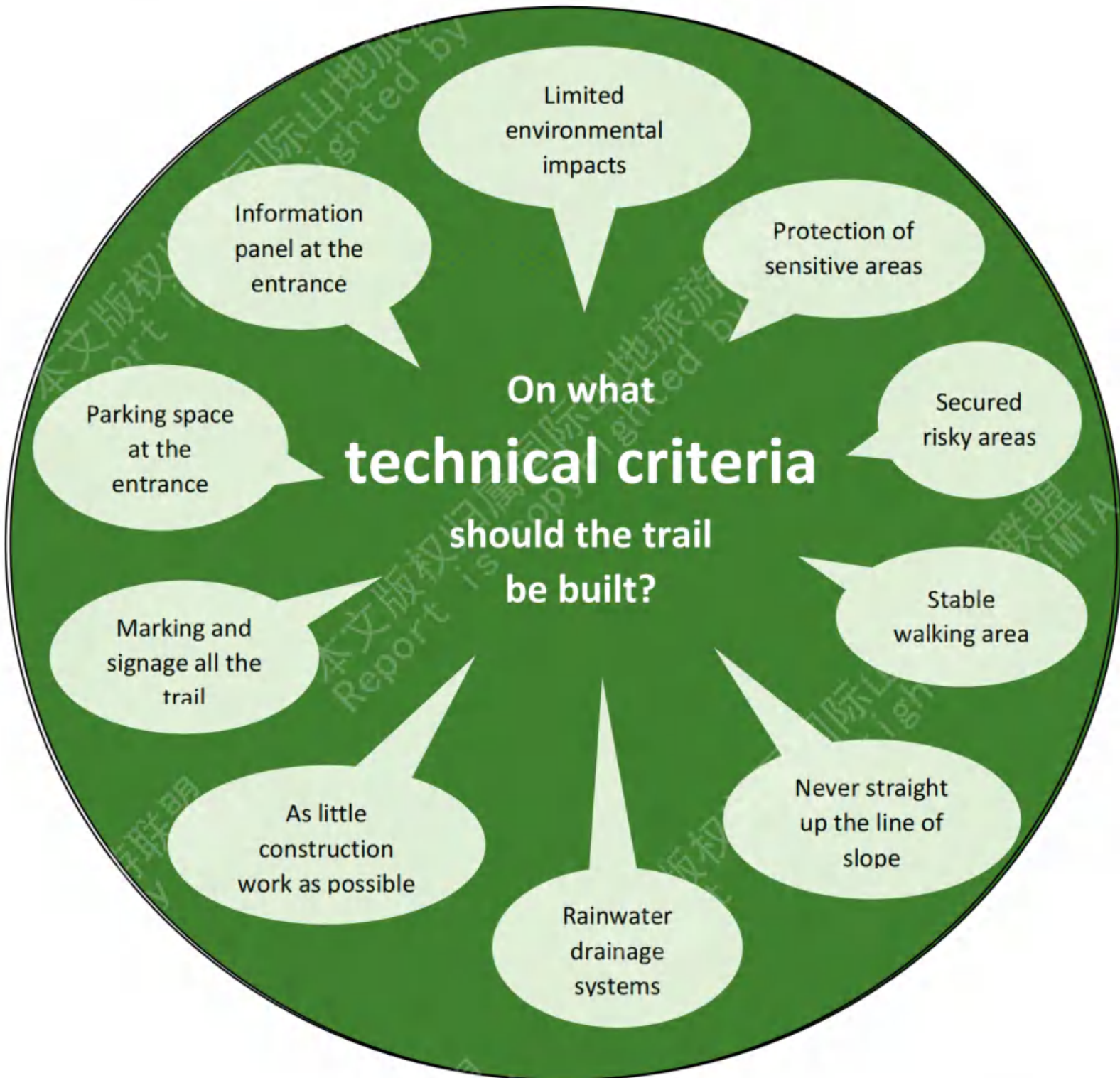

UNDERTAKE THE CONSTRUCTION OF YOUR TRAILS

7

The specifications are given by the technical report for the design of the trails (refer to: P2 - Chapter 6). Generally, the main part of this work consists of adapting already existing trails and paths to the practice of tourist hiking.

This work will mainly be:

- Brush cutting, pruning;
- Reinforcements of the base of the trail;
- Drainage systems;
- Stone pavements
- The repair of low walls;
- The construction of river or road crossing works;

Additional amenities that can be constructed:

- Building of a parking area at the start of the trail
- Installation of garbage cans at the entrance and exit of the trail and at the inhabited stages;
- Development of picnic areas;
- Installation of points of crossing over boundary fences;
- Etc.





© Serge Koenig: creation of a new trail at Pingle within the framework of the Alpes-Sichuan cooperation, Chengdu (China)



© Vosgien Club: creation of a new trail on the stubble of the "Green Grass" between Alsace and the Vosges mountains (France 2019)



MARK AND SIGNPOST YOUR TRAILS

8

The marking and direction signage complete the creation of the trails. These markings along the routes are essential, except in the case of an offer based solely on accompanied and guided hikes.

The most important (and often the most complicated) is to, beforehand, define a marking charter with its route identification codes. A China-specific charter is proposed in this chapter. It should ideally be accepted (as is or modified) on the scale of the largest possible territory. In the absence of a common charter between neighboring sites, the towns and counties, there is risk of proliferation of markings of all shapes and colors that will ultimately be incomprehensible to trail users. This risk is even greater if there are other activities with their own markings, for example, mountain biking, horseback riding, trail running, etc.

This chapter indicates the main techniques for marking and directional signage

CHAPTER SUMMARY

- 8.1 Route layout: Three Options
- 8.2 Recommended hiking trail identification codes in China
- 8.3 Trail marking techniques
- 8.4 Directional signage and pictography
- 8.5 How to plan the marking and signage work?
- 8.6 Information signage on furniture

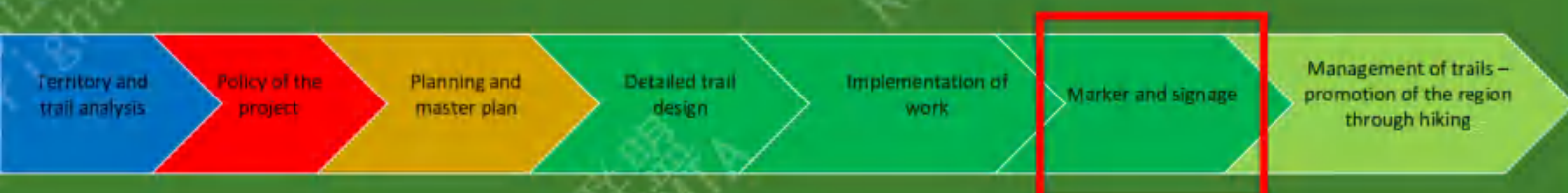



8.1 - Route layout: three options

Marking and signage can be considered in three different ways, depending on the way in which the different routes fit together.

- Do you want one or a few clearly identified routes with marked and differentiated codes that users can follow from start to finish? This is route configuration.
- Do you want a network of intersecting routes, each of which has its own identification allowing the user to follow their original route or change routes? This is routes network configuration.
- Do you want a network of trails with direction marks, with indications of the main and intermediate destinations, leaving users freedom to choose which trails they want to take to reach their goal? This is intersections network configuration.

This choice of the articulation of the routes will depend on your objectives, the nature of the project, the network of existing trails, and the characteristics of the territory. It will also depend on how the trail offering has been designed, how they relate to points of interest, your promotion and even your marketing strategy. These three principles and the options they pose should therefore be taken into account starting from the planning and master plan phase.

	ROUTE CONFIGURATION	ROUTES NETWORK CONFIGURATION	INTERSECTIONS NETWORK CONFIGURATION (recommended configuration)
Description	Each route is individually and independently marked, making it easy to follow	<ul style="list-style-type: none"> - One trail = one mark type. Each route has its own identity (names, colors and numbers) - Common trail sections are marked with several IDs - Directional signage is installed at crossings. 	<ul style="list-style-type: none"> - At each intersection, direction signs guide the walker to the next intersection. Between the two, there can be a paint marking (identical ID for the whole network). - The users choose their personal routes to reach the destination of their hikes. - The user must be more independent here than in the other options
Appropriate situations	<ul style="list-style-type: none"> - If there is only one or few routes; - If the routes are managed by different operators; - If the attendance must be channeled or it is not important. - If these are large, structural and/or emblematic linear trails, with no length limit. 	<ul style="list-style-type: none"> - If the territory is not very large and with few overlapping routes; - If there are different types of trails and routes; - If the attendance of the routes is important. 	<ul style="list-style-type: none"> - If the network of routes is dense with many convergences and common sections; - If the network is in the development phase; - If the network is managed by a single operator; - If the monitoring of trails and signage is permanent and well done.
Main advantages	<ul style="list-style-type: none"> - The simplest technique with a minimum level of equipment (mainly marking); - No or few direction signage; 	<ul style="list-style-type: none"> - The reading and orientation are easy for novice users; - The marking system has various marking types that are easy to follow. 	<ul style="list-style-type: none"> - It offers great freedom to users; - It is suitable for all forms of practice; - It encourages the independence of users; - It allows an evolution of the trail system; (enlargement, change of configuration); - It integrates well with local recreational uses; - It allows to better promote the identity elements of the territories.
Main disadvantages	<ul style="list-style-type: none"> - The offer is hard to modify in the event of a trail network increase or a change in demand; - Potentially inconsistent marking/signpost between the routes; 	<ul style="list-style-type: none"> - A lot of information to manage: lots of markings and directional arrows (especially if the trails are marked in both directions); - The system is difficult to modify in the event of a trail network increase or a change in demand (or the operation will be expensive). 	<ul style="list-style-type: none"> - The system requires marking of routes in both directions; - The users must be independent or know a little about the geography of the territory. They must be able to decrypt the trail network with a medium (map, guide, file, GPS track, etc.) or have route suggestions. - Can be more complicated with multi-activity trails (hiking, + bike, + horse, + trail, etc.) because the coexistence is systematic
For what use?	- For tourist use in particular.	- For tourist and community use.	- For community and tourist use.

"Route configuration" of one major trail and some peripheral routes.

This example of organization shows few interconnections and an identification specific to each route, with simple and easy-to-follow directions.

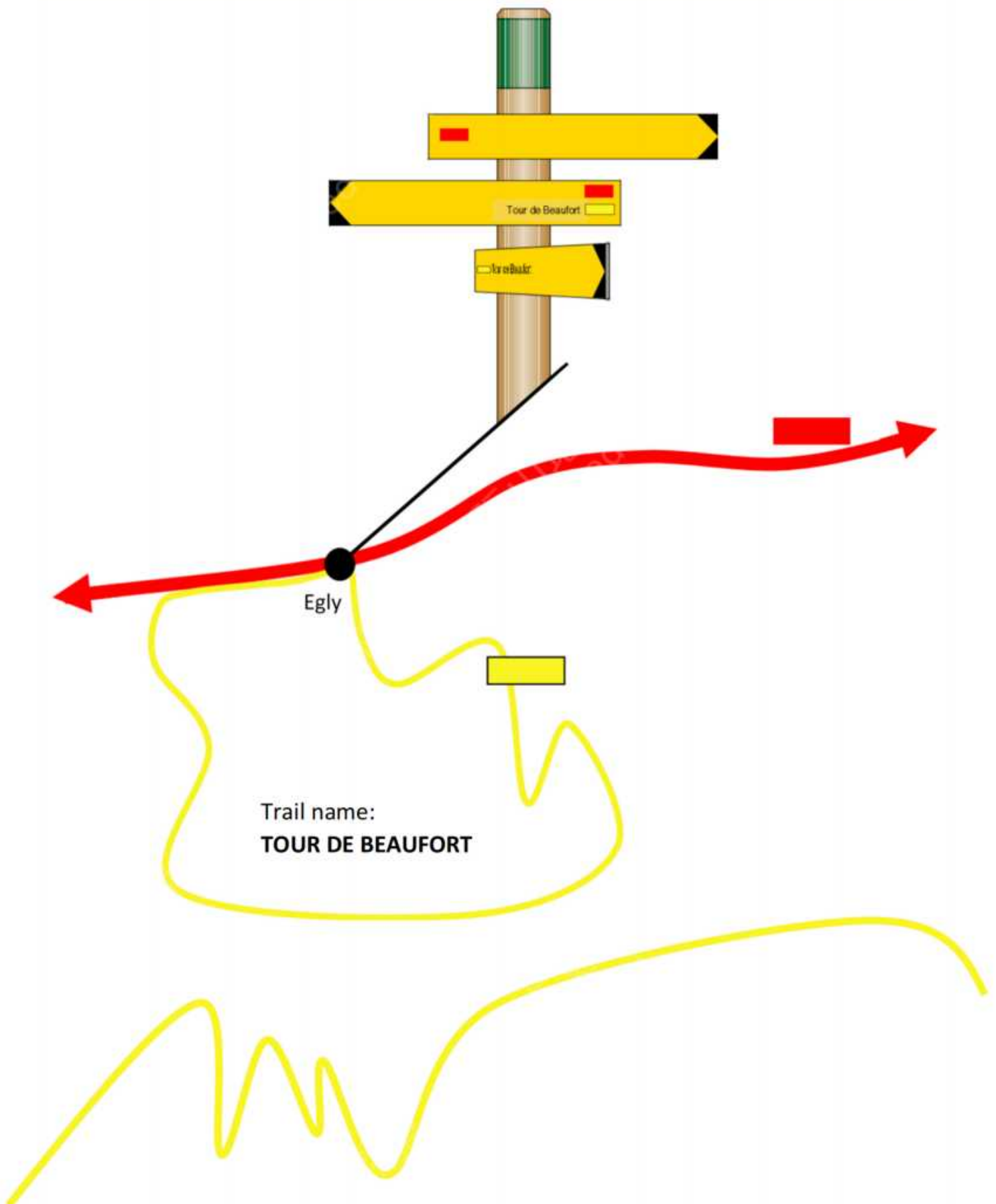

(Source: inspired by technical notes from the French Hiking Federation)

"Routes network configuration " with one major trail and other more local trails.

This example of organization shows frequent crossings and common sections, specific IDs for each route, and directional signage indicating the main destination at each intersection.

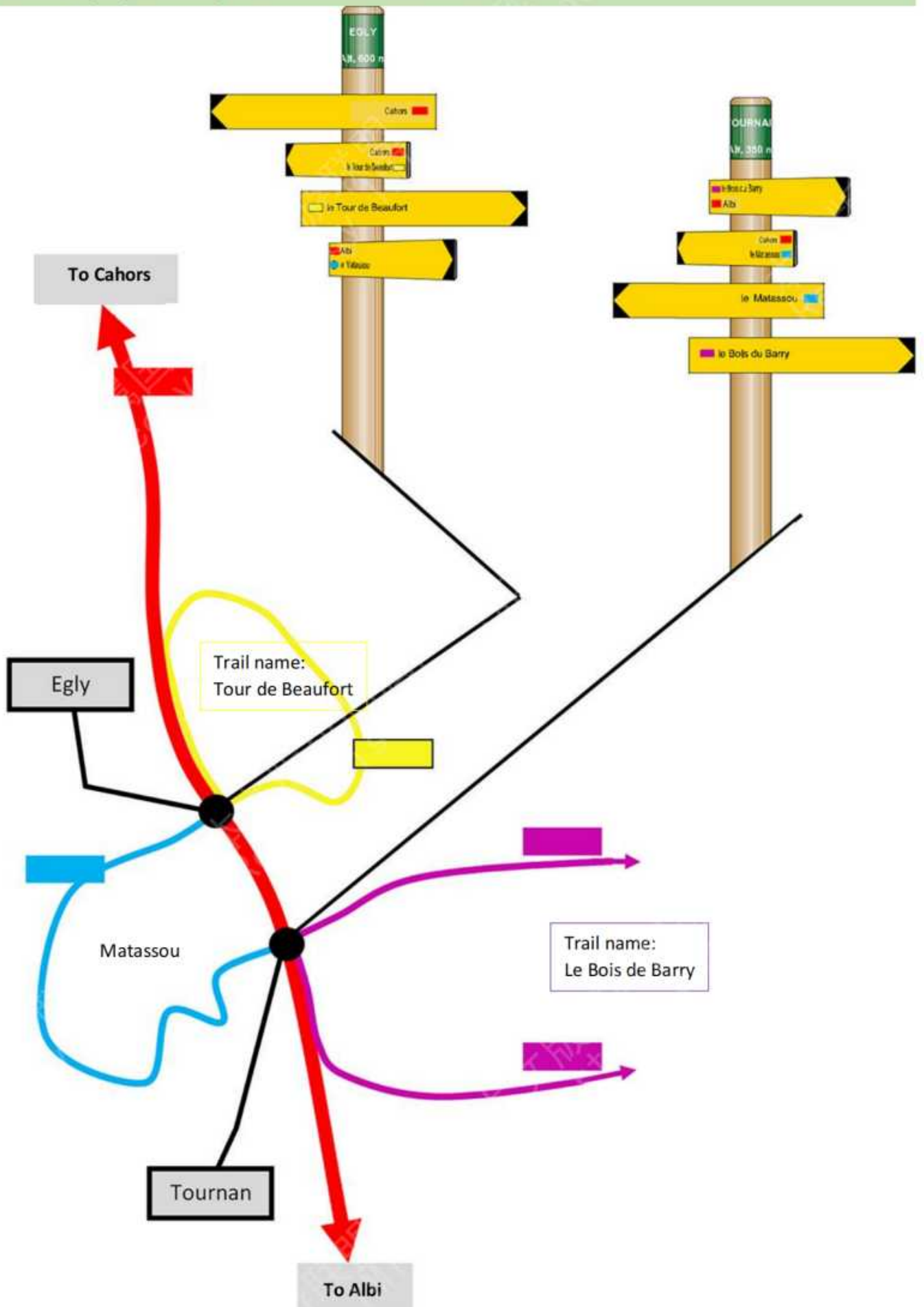

(Source: inspired by technical notes from the French Hiking Federation)

"Intersections network configuration" with one major trail and other more local trails.

This example of organization shows frequent crossings, a route with its own ID surrounded by a network of other trails (which may be without colored markings or have a common color). The main indications are the destinations.

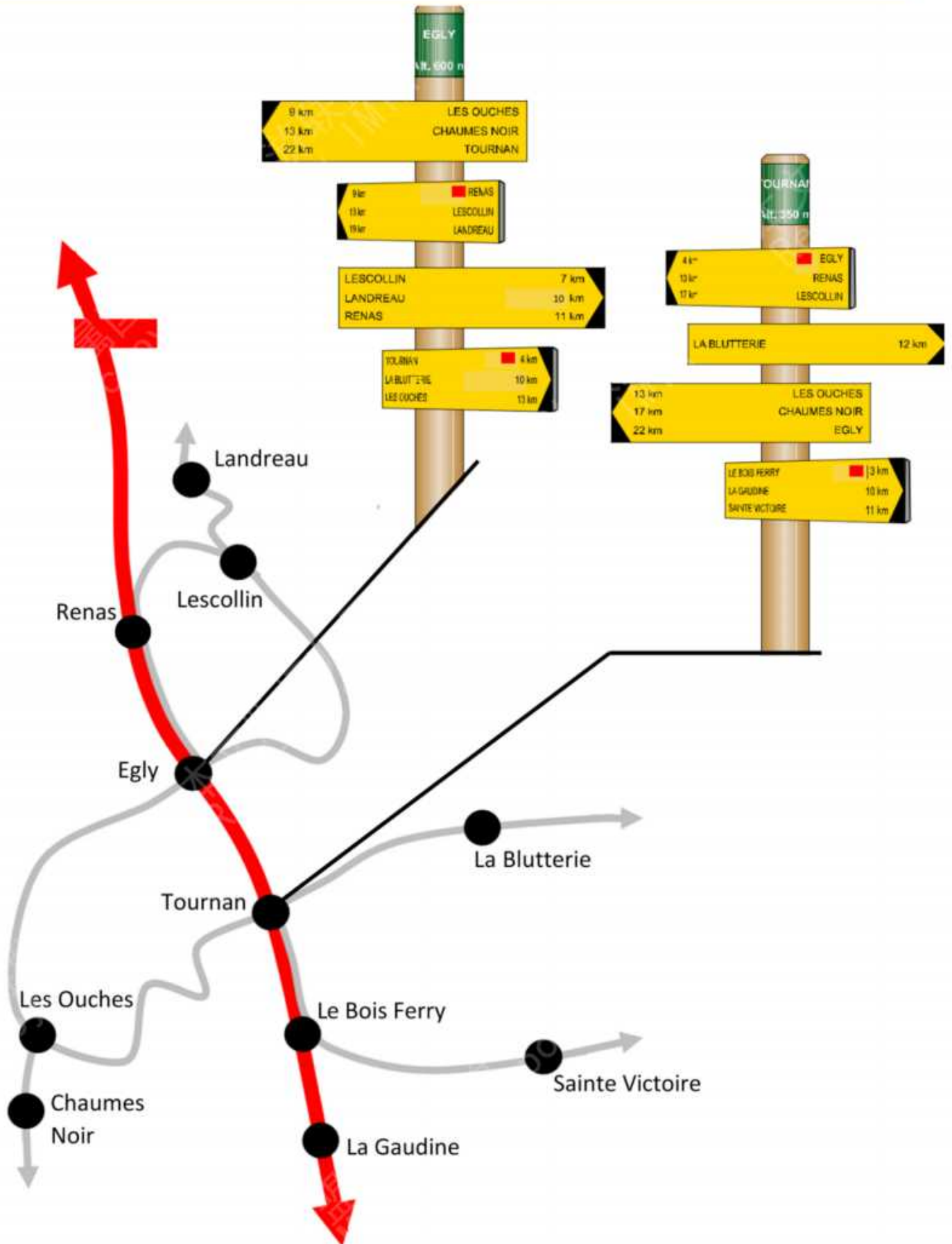

(Source: inspired by technical notes from the French Hiking Federation)



8.2 – Proposal of a trail identification code for China

This basic charter, original for China, is a proposal inspired by existing charters in different regions and countries (in particular France, Spain, Switzerland, and Canada)



COLOR CODES

	Short hiking route (< 15 km)
	Hiking route (15 to 50 km)
	Long distance hiking route (for 2 to 7 days)
	Inter-regional or inter-provincial super long-distance hiking route (> 7 days)

The signals are horizontal. The common color is red like the Chinese flag. The 4th red/red sign is the identification of the longest trails (potentially cross-territory trails at national level)

Adaptation of these color codes to intersections not equipped with directional signs/arrows:

- The route takes the trail on the right or on the left



- The route does not go through this trail





THE TECHNICAL DIFFICULTIES OF THE ROUTES WITH CORRESPONDING PICTOGRAMS:



Easy walking-hiking



Medium difficulty hiking



Difficult hiking



Sports hiking

The most difficult section determines the difficulty of the entire route.



NUMERICAL IDENTIFICATION OF THE ROUTES:

X1

...

X107...

Local level route, of a County

S1

...

S78...

Municipal, prefectural and provincial level route

G1

...

G8...

National level route (interprovincial or cross-border)

This route number/letter identification system is inspired by the identification system of Chinese roads and the administrative divisions of the territory (national, provincial, prefectural, municipal and county-level).

This identification can, whenever possible, be accompanied by the name of the route, for example "the tour of the lakes", "the crossing of the sacred peaks", "the tiger gorge hike", etc. Routes with evocative names and/or attractive logos provide better promotion than just numbers.

Any use of numbers for the launch of a hiking route that can be integrated into a territorial development plan must be coordinated between all the decision-makers concerned with hiking, tourism, sports, traffic routes, planning, etc., in order to be recognized and potentially registered.



THE SIGNAGE OF THE PARTICULAR INTEREST OF THE ROUTES: PROPOSAL FOR "THE IMTA TRIANGLE"

IMTA labeling could be established to inform hikers on the trails offering the best experiences (refer to: P1 - Chapter 5).

Such labeling requires a fully-fledged study, in particular with the refined definition of objective and precise criteria. This is just one of the ideas that can be explored to develop trails and hiking in China.

Very interesting



Exceptional



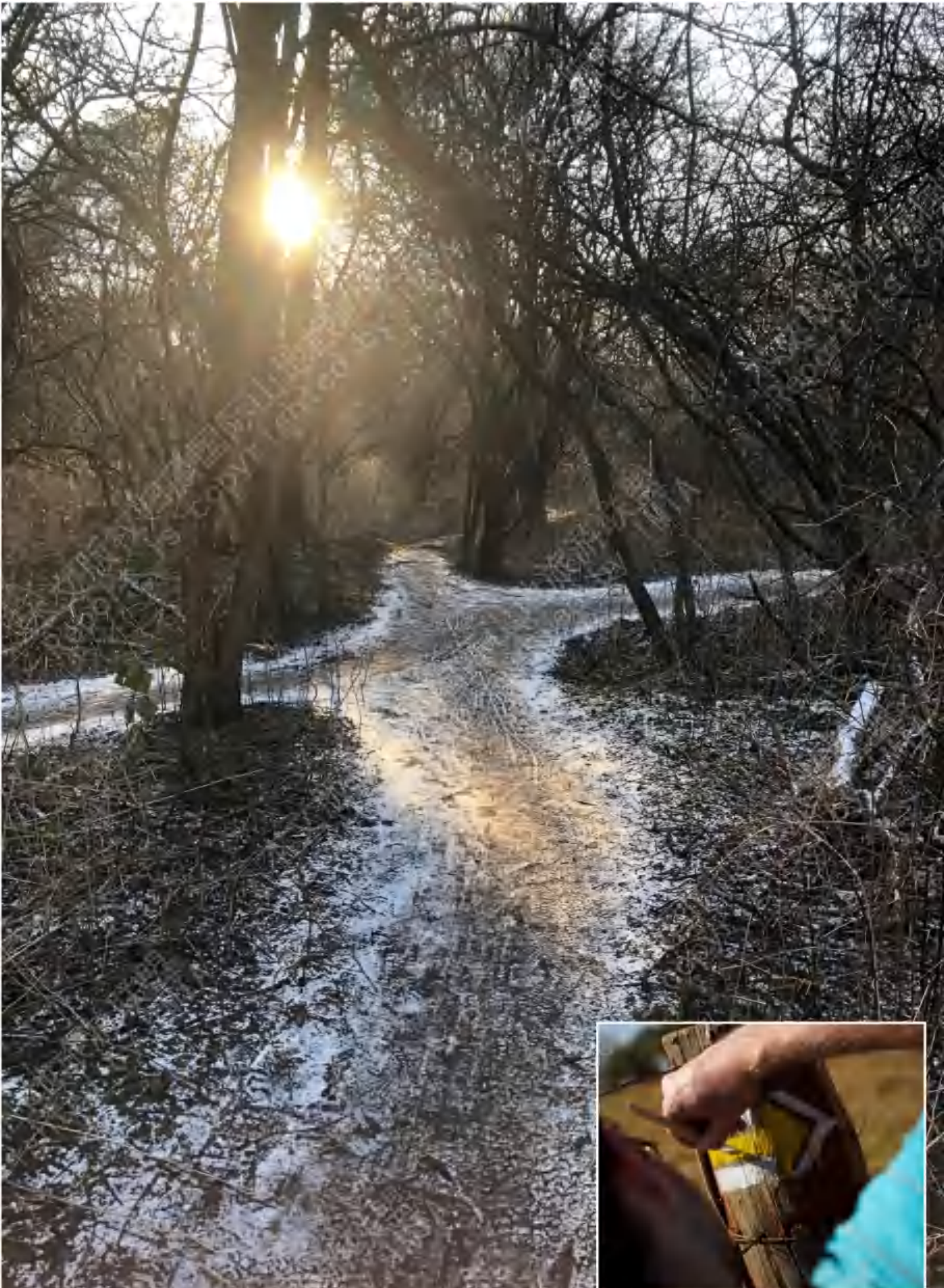

© Serge Koenig: Intersection of peri-urban paths in Copenhagen (Denmark 2021)

© ERA-EWV-FERP: waymarking in Czech Republic

8.3 Trail marking techniques

In the past, trail markings were generally carved out with machetes on tree trunks or by cairns (piles of stones visible from afar). Since the development of tourist hiking routes, this marking is now carried out with colored signs generally painted on natural supports such as rocks and dead trees (marking is ideally not placed on living trees out of respect for nature), or artificial supports such as posts, bollards, panels, and walls (markings will never be affixed to natural or built heritage elements that could be deteriorated or damaged).

These signs mark out the trails so that walkers can follow their route without the risk of getting lost or endangering themselves. This marking in the field is the essential complement to topography guides, GPS and other connected instruments, maps and other information documents intended for walkers.

It indicates and confirms the right direction, changes of direction, etc., the frequency of the signs depends on the landform. The signs are installed regularly along the routes, especially in strategic places. However, it must not be installed excessively to maintain the natural and unpolluted character of the site.

The charter for this trail marking often varies according to the site, region, and country. But for an efficient development of the activity and to promote inter-territorial continuity of tourist trails (as this guide advises for China), these signs, their dimensions and their colors should ideally be harmonized on a large scale to offer practitioners the same type of standardized and easily understandable indications over a large area. This standardization is necessary in a coherent policy for the development of tourist and sports hiking leisure activities, and necessary to formalize a tourist hiking offer.

This harmonization of the marking system makes it possible above all to avoid misleading walkers, especially as there may be other heterogeneous markings along the paths and trails, such as arrows for other types of outdoor activities practiced on the same routes (mountain biking, cycle touring, trail, horseback riding and others with which the hiking trail markings must be coordinated), signs of forest workers, signs of demarcation of land plots or municipal boundaries, etc. The old markings must be systematically erased when modifying or renovating the route and its signage so as not to interfere with the understanding of walkers.

If the installation only requires a relatively simple technique, the marking and signage system is the direct result of a well-thought-out and constructed process and of the configuration of the routes or of the network (presented at the beginning of this chapter).

WHERE ALONG THE ROUTE SHOULD THE COLOR SIGNS PLACED?

Principle 1: the signs must be visible and facing the users.....

Principle 2: signs must not be placed laterally to the direction of travel.....

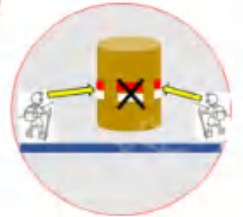
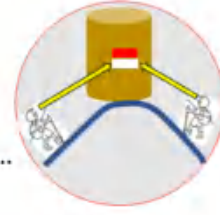

EXAMPLE of placing the painted color signs in one direction on a section of trail:

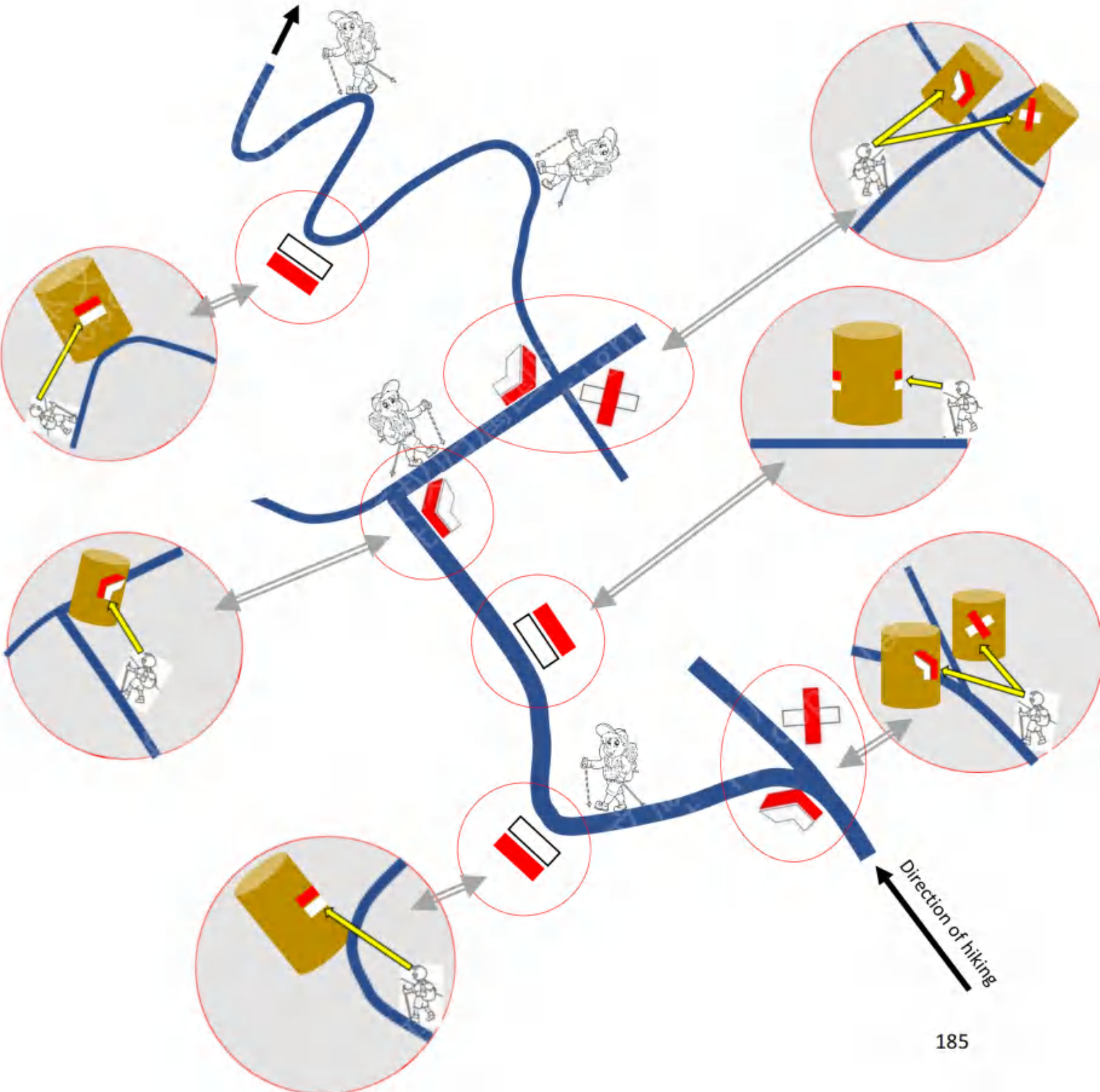



EXAMPLE of marking in the other direction (on the same section of trail)

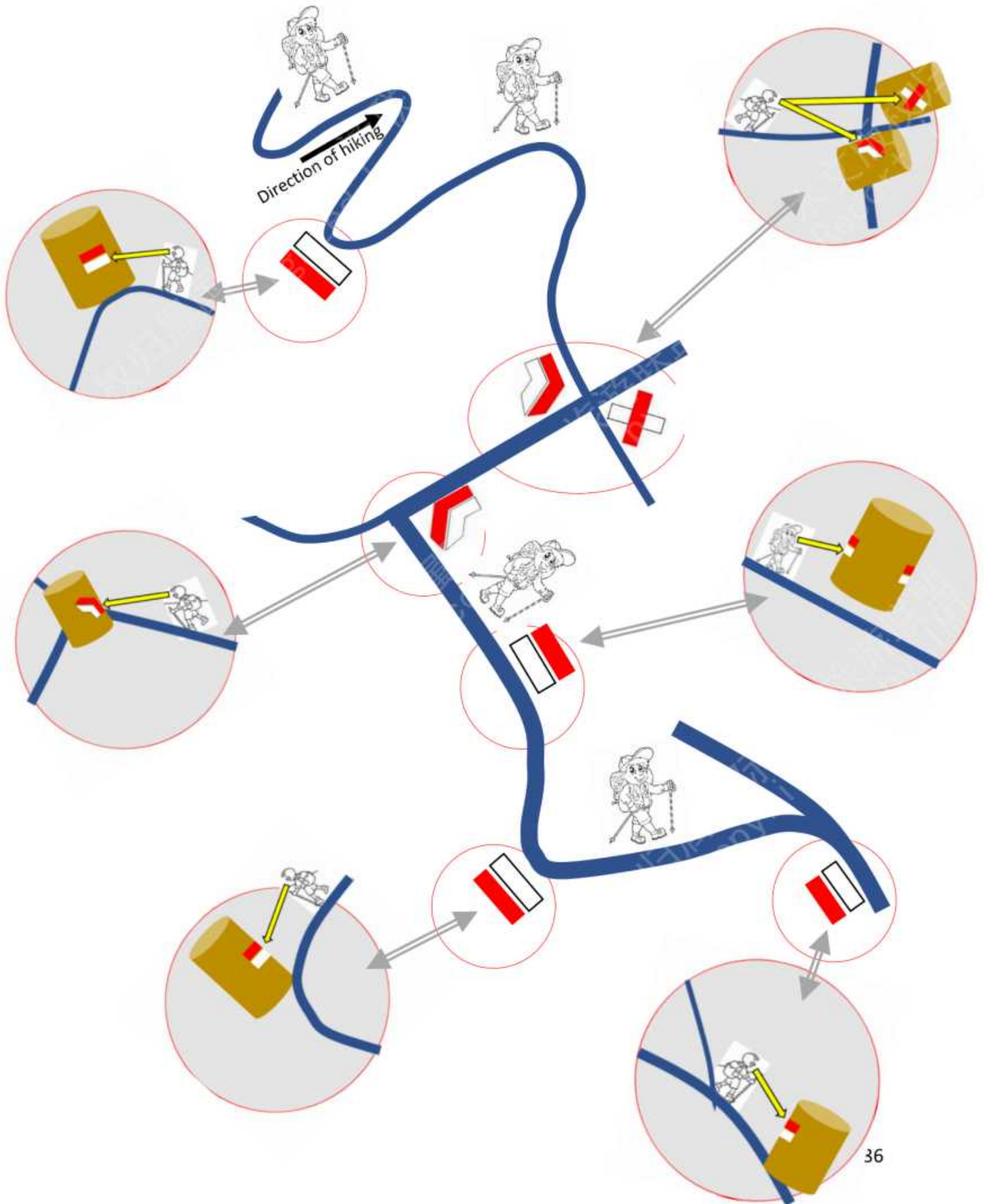



EXAMPLE of placing difficulty level signs parallel to the marking on a varied hiking (sectional plan). They are particularly useful when informing the walker of the increased difficulty and escarpment.

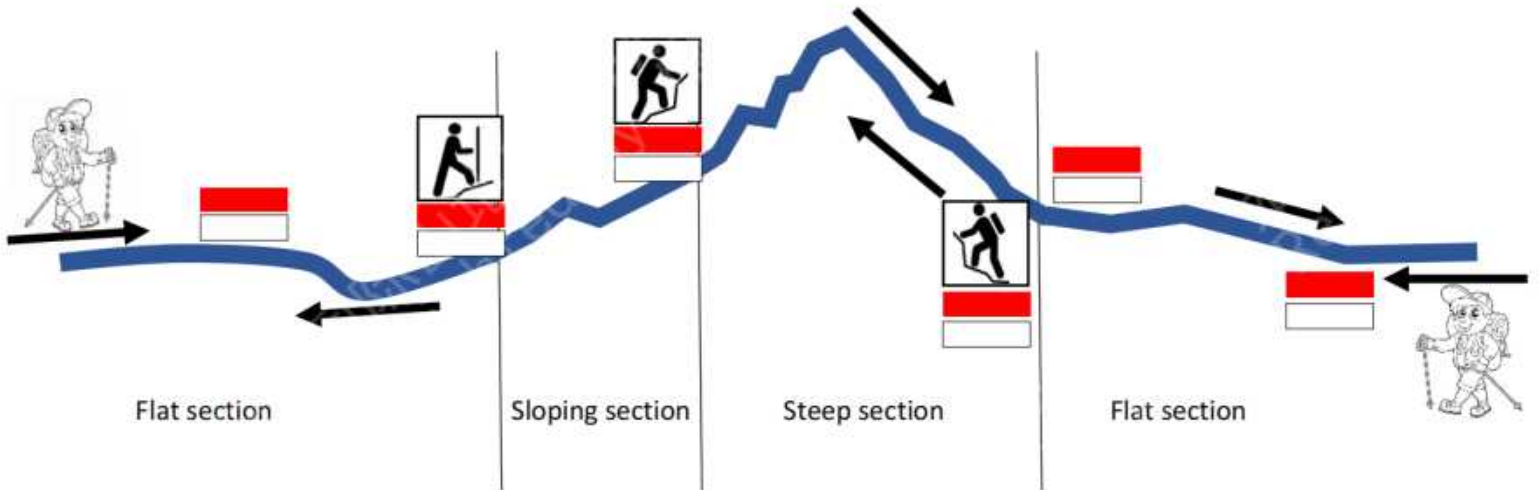

WHAT DIMENSIONS? WHAT SUPPORTS?



The main painted color signs

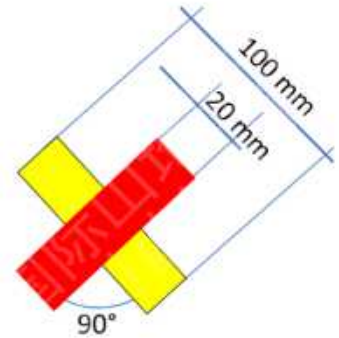
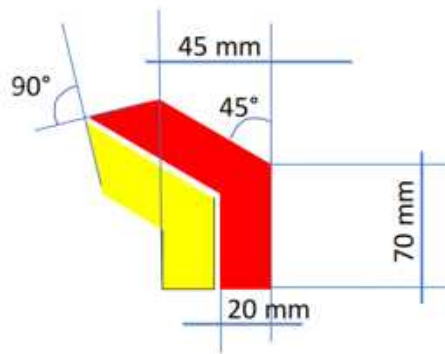
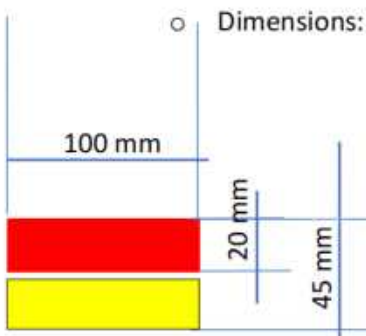

- Colors:
 - Red and white, red and yellow, red and blue, red and red;
 - Red is always placed on top;
 - The colors are those of the color codes indicated in sub-chapter 8.2

- The layout:
 - The positioning of rectangular signs is always horizontal;

- It must be set up in a place and on a durable support visible for walkers, i.e. facing the walkers.
- The sign is:
 - Either painted directly on the support using a stencil and a brush;
 - Printed on a plate which will be fixed (glued, nailed or screwed) on the support;
 - Or on a durable sticker.
- Materials;
 - The paint should not be harmful for the environment;
 - The plates can be made of wood, PVC, resin, or aluminum.



The pictograms for the difficulty levels

They are black and white, either printed on square plates fixed on the supports (glued or screwed), or on durable stickers.

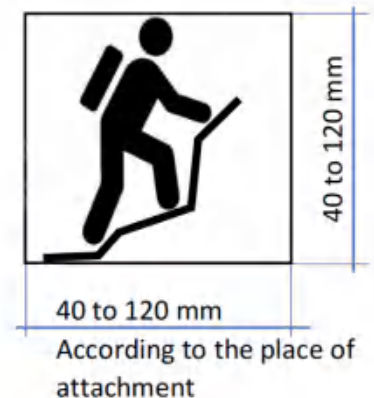

Supports

- Give priority in use of natural or artificial supports that are already installed, whose color must allow good visibility of the signs



- Specially fitted wooden posts if a natural support is not available. For this type of support, it is preferable to use posts with a square section rather than a round section because it will be easier to affix the pictogram plates. The top of the post will be cut into a cone to facilitate rainwater flow. Any wood used should preferably be local species (oak, chestnut, Douglas or Scots pine).

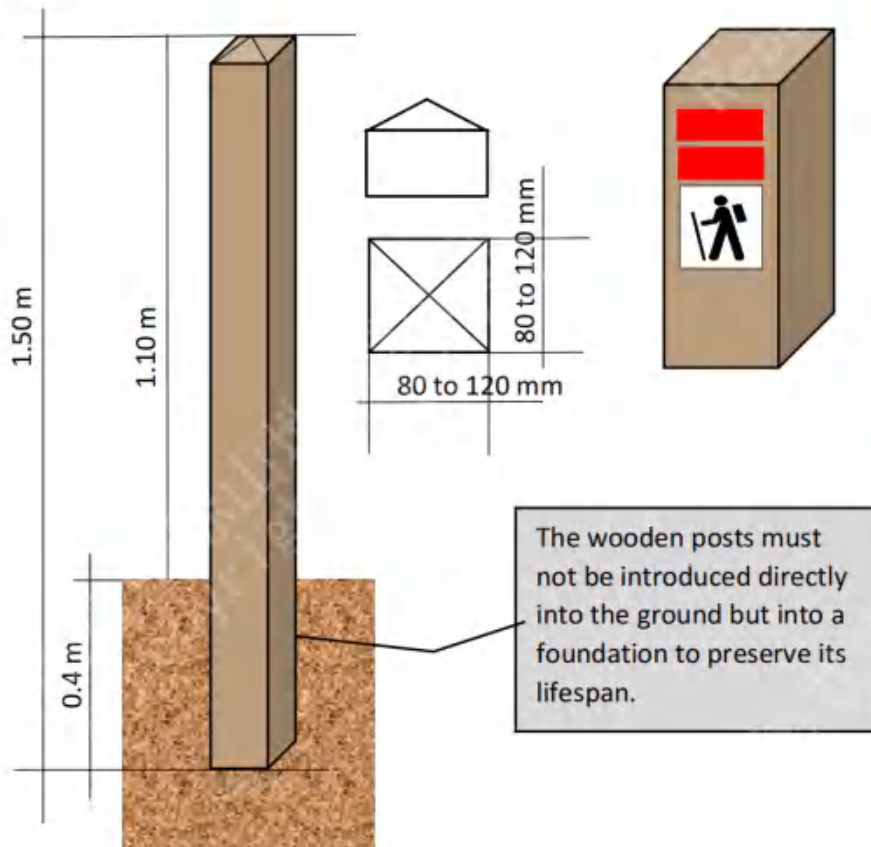

Source: FFRP France

These colored signs are placed at eye level, especially at intersections and in places with potential confused routes. Fewer signs can be used if the trails intersections (with directional signage and arrow panels) are close to each other, and more signs will be needed if these trails intersections are far away or without direction signage.

Basically, these colored signs are set up to reassure hikers and confirm that they are on the right way and going in the right direction. As soon as there is a possible source of hesitation on the part of the hiker, for example on an insignificant crossing, a colored sign must be provided. Signs must be visible in both directions of travel on the route.

There is no standard distance between two colored signs. On a long section without crossings, the frequency of the signs should be every 10 to 30 minutes: hikers should not have to worry about if they are on the right path. Their placing is decided by the person who carries out the marking and signage locations and who defines the plan for these arrangements (refer to: sub-chapter 8.5).



© Serge Koenig: sheepfold on the wild trails between Caoke and Halluogu, southern slope of the Gongga Shan massif (China 2017)



Directional signage with arrow panels

Information collar of the number of the municipality

Trail pictogram

Location information panel with name and logo

Pictograms of protected area regulations

Marking color sign of the trail

8.4 - Directional signage and pictography

These include the arrow panels that indicate where we are, where we are going, and where we are coming from.

They give us directions, intermediate and final destinations, color codes, route numbers and names (if available), level of difficulty, direction of travel, connections with other trails, exits to villages, nearby public transport stations, car parks, cable car stations, refuges, restaurants and other services.

These arrow panels are installed in strategic places, in particular at trails intersections. However, they must not be installed excessively in order to keep the natural and unpolluted character of the site. The signage system must be adapted to the different environments crossed (urban, rural, forest, mountainous areas) and be accepted by the owners and managers of public or private land crossed by the trail. It will need to be standardized across the entire trails network.

The clearer, simpler and more concise the information is, the better it will guide and reassure hikers, and less safety measures will be necessary on the trail.

In addition to being made of eco-responsible materials, this signage must comply in its design and installation with quality criteria in terms of aesthetics and harmony with the landscape and the environment, the legibility, the maintenance, and the durability, and be both discreet and visible in both directions of the route (clear at all times, at a height adapted to climatic conditions and the characteristics of the environment).

Same as the colored signage, the installation of these panels, arrows and posts only requires a relatively simple technique, but the planning process is more complex than it seems.

The principle of signage will generally be the same whatever the configuration of the routes or the network is (presented at the beginning of this chapter), but with more or less signs and potentially different information.

The signage, it is also considered to be an effective tool for promoting the hiking activity and the whole region.

INDICATION OF THE INSTALLATION PLACE OF THE PANELS/ARROWS PANELS

The information at the top of the support poles of arrow panels indicates "where we are": the name of the place, the altitude and optionally the municipality number and the GPS coordinates.

The information is written either on a panel or on an aluminum ring at the top of the pole. The panel option makes the information more visible and let the surface of the collar as a space for the town or site promotional.

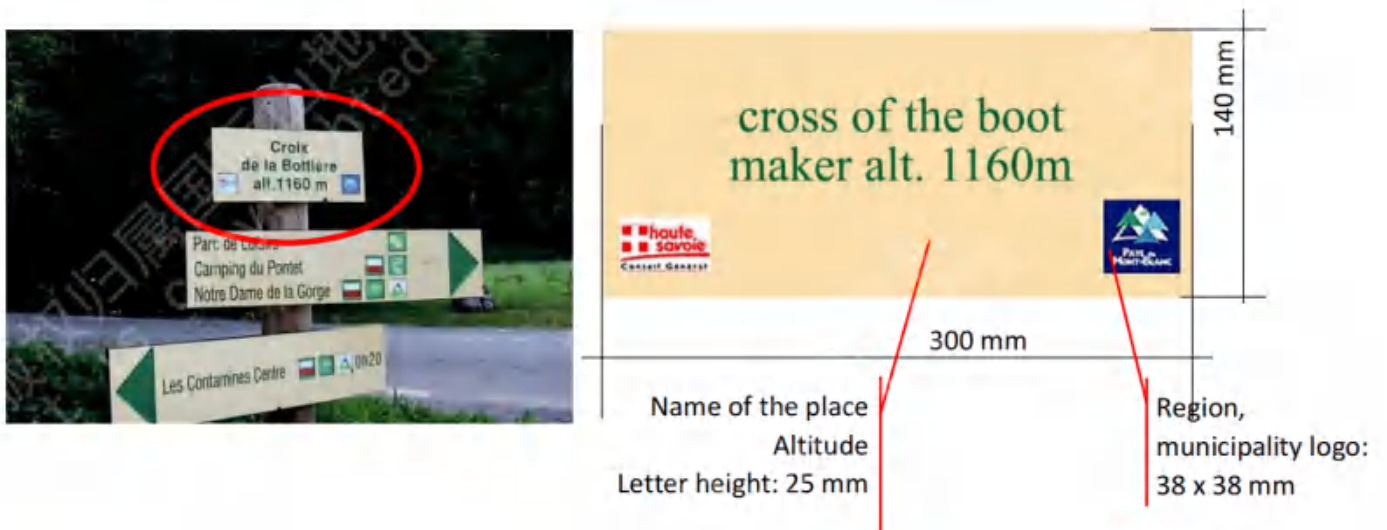

Example of location information on a collar placed at the top of the pole:

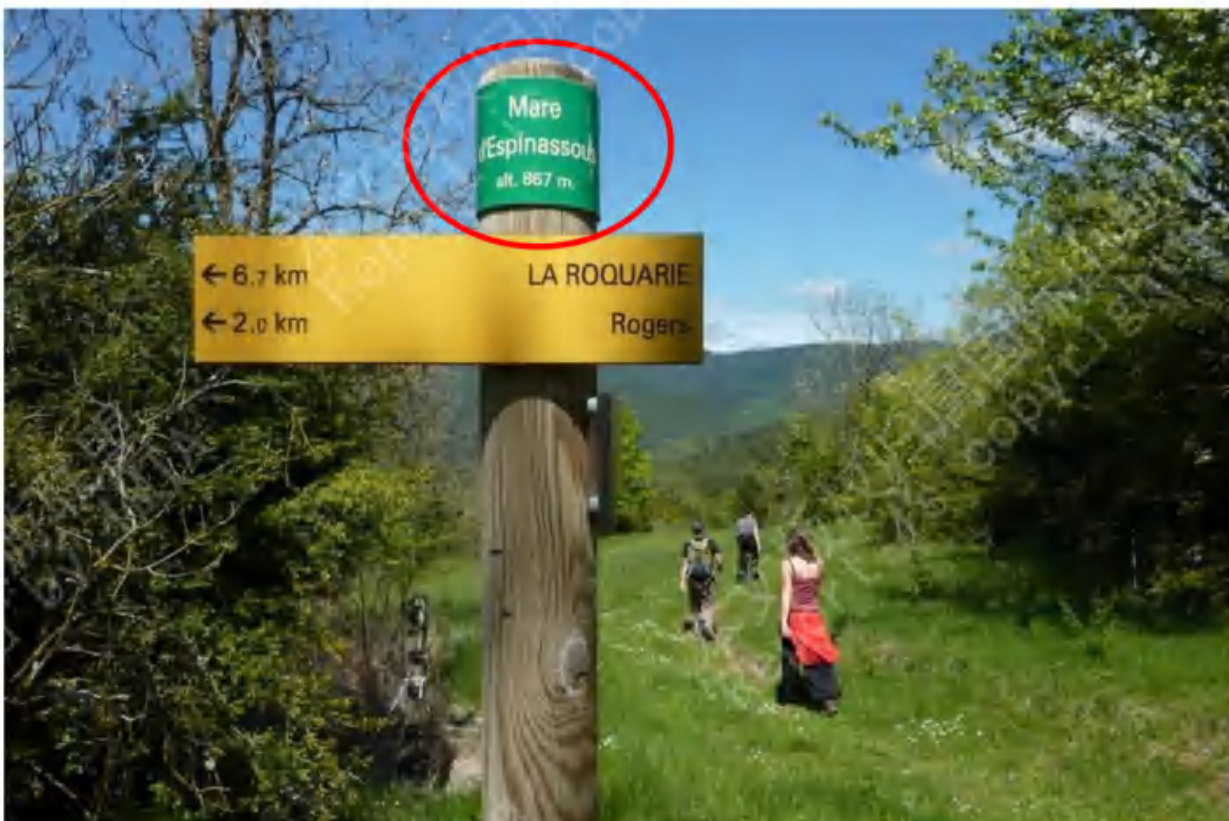

DIRECTIONAL ARROW PANELS: RECOMMENDED SYSTEM

The arrows are printed on the rectangular panel to avoid complicating the manufacturing and cutting process. In addition, rectangular panels will be more resistant to bad weather than a panel cut in the shape of an arrow as the tip is fragile.

This paragraph gives the principles and essential measures of arrow panels by insisting on the necessary homogenization of a detailed graphic charter (spacing, line spacing, type of characters, etc.)



The information line is always left aligned in the direction of reading from left to right:

- The destination (or the objective of the hike);
- 0 to 3 pictograms (maximum);
- The hiking time to the indicated destination;
- The distance to the indicated destination.

In mountain regions, the time indication predominates (and the distance is optional) while in flat areas, the distance indication predominates (and the time is optional).



The location and number of written lines

- The lines are aligned on the left and harmoniously distributed over the height of the panel;
- There are a maximum of three lines on the standard panel;
- If there are four lines, the panel must be larger to contain all of the lines;
- If there are five lines or more, they should be distributed on two panels (with three and two lines respectively).



The order of the lines on the same panel depends on the objective destinations of the hike

- The top line is the closest destination;
- The next line is the intermediate destination;
- The bottom line is the main (or final) destination of the route (the objective of the hiker).

This order is based on time and/or distance, for example: 0:45, then 1:50, then 3:00, then 3:35...

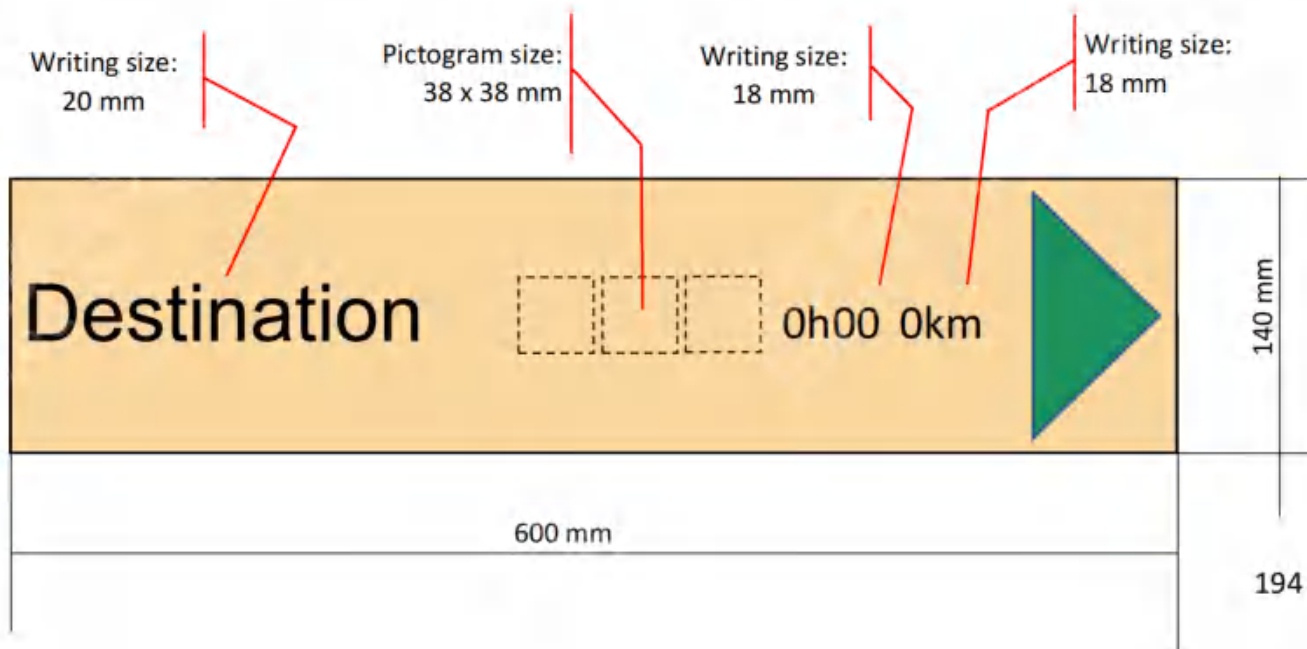

- Two lines

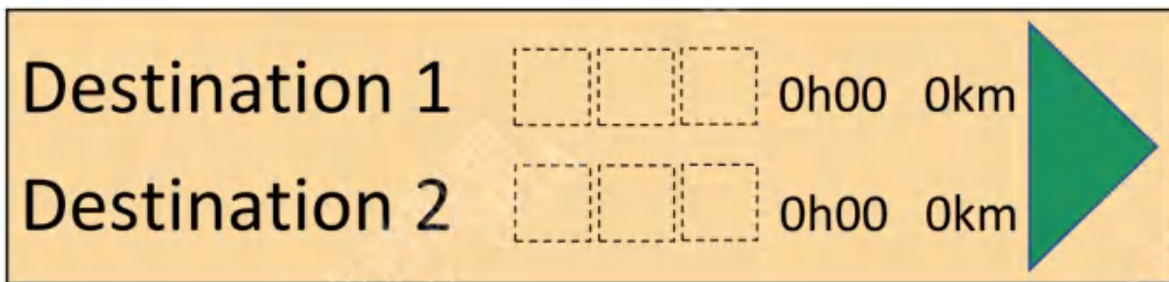

- Three lines

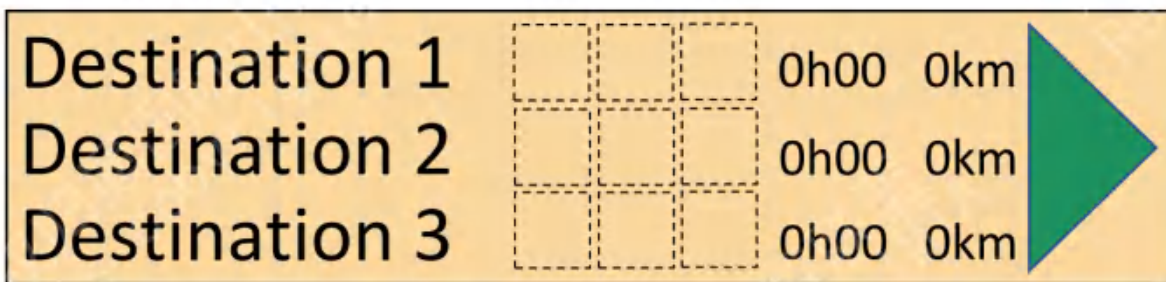

- Four lines (slightly larger panel)

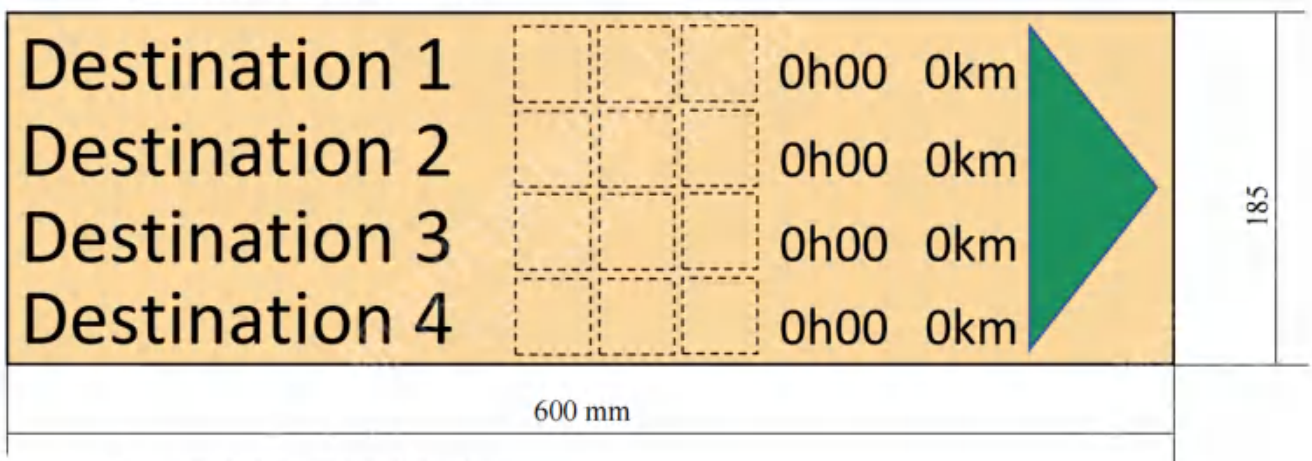

- Arrow panel in opposite direction

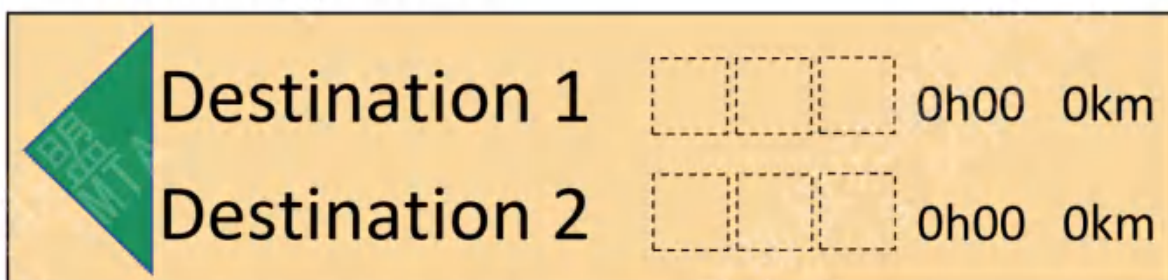

(Source: inspired by the Haute-Savoie marking charter)



Subtitles

A destination may include additional information below the main line (in italics of an 18 mm writing height). This information can be the name of the trail (for example "*trail of White Lake, trail of the mountain ridge*") or indicate a significant point on the way to the destination (for example "*trough village of Renas*")

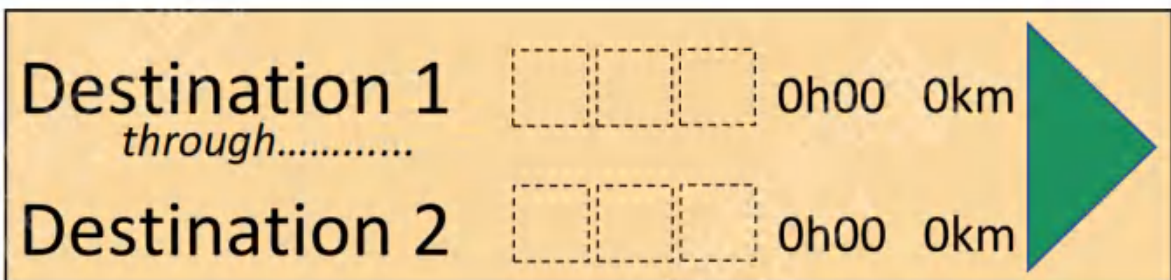
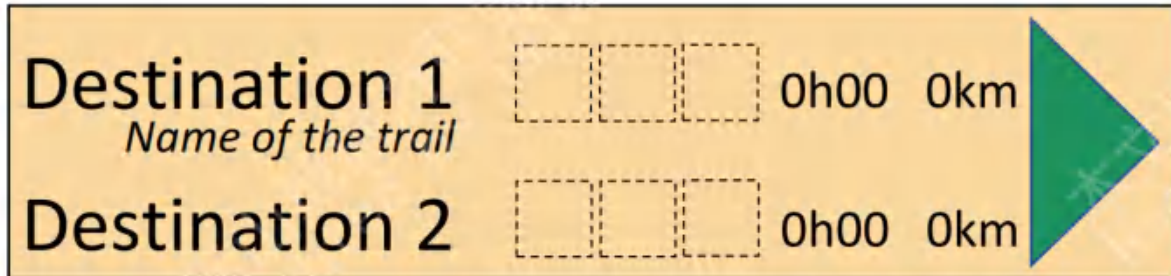

Consistency of the signs and panels

- Panels of the same type, same color (light wood beige), same material;
- Writings in the same font, same size, same color (black or dark green);
- The pictograms indicated for a destination must be repeated at each mention of this destination until this destination arrival.



Arrow panels are mounted on a pole with a maximum of four arrows per pole. If five arrows are required, there must be two support poles.



All direction options, especially "where we are going" and "where we are coming from" should be indicated on the directional arrows.



EXAMPLE of a directional intersection

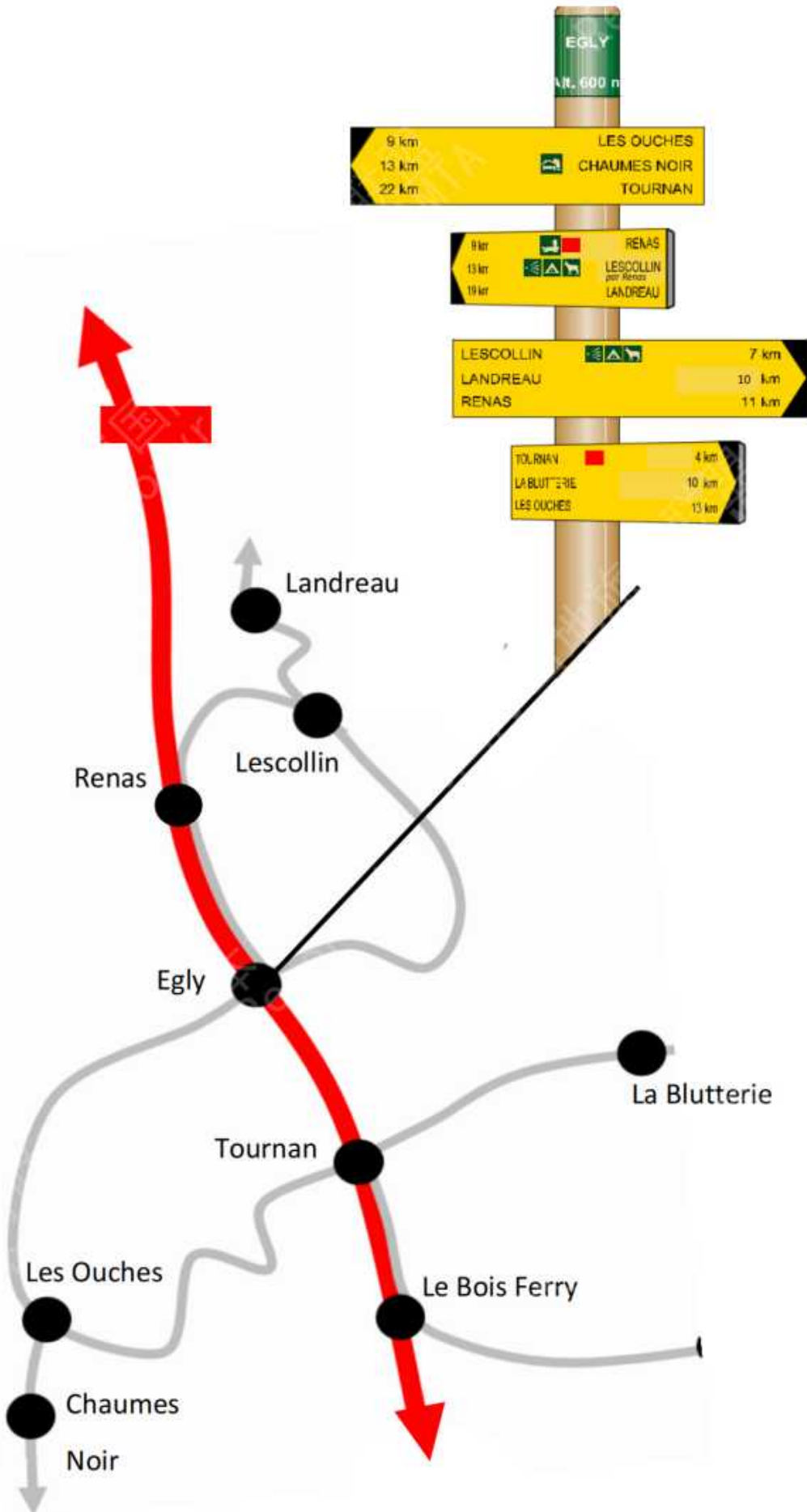



The different materials of arrow panels

- In © Trespa Meteon or equivalent, made of pigmented resins with different colors. Thickness: 13 mm. Durability: 30 years. Color fastness: 10 years. Easy to maintain;
- In MEG print or equivalent, composed of layers of cellulose fibers impregnated with resins. The surface layers are formed of sheets with decorative colors and designs resistant to bad weather and solar radiation. Color fastness: 10 years. Easy to maintain;
- Made of wood from preferably local species (oak, chestnut, Douglas-fir or Scots pine). This natural material is the best option but requires significant and regular maintenance to make it durable;
- In 1 cm thick resin: a material extremely resistant to UV rays, bad weather, acts of vandalism. Almost infinite durability and maintenance free, but at a higher cost.
- In hard, polished aluminum, 5 mm thick with digital printing on film and anti-UV lamination.



Support poles (or masts)

- Existing posts: electricity, telephone, road sign posts, etc.
- Specially designed posts (wood or aluminum) and round section (for easy orientation and fixing of the panels in all directions).

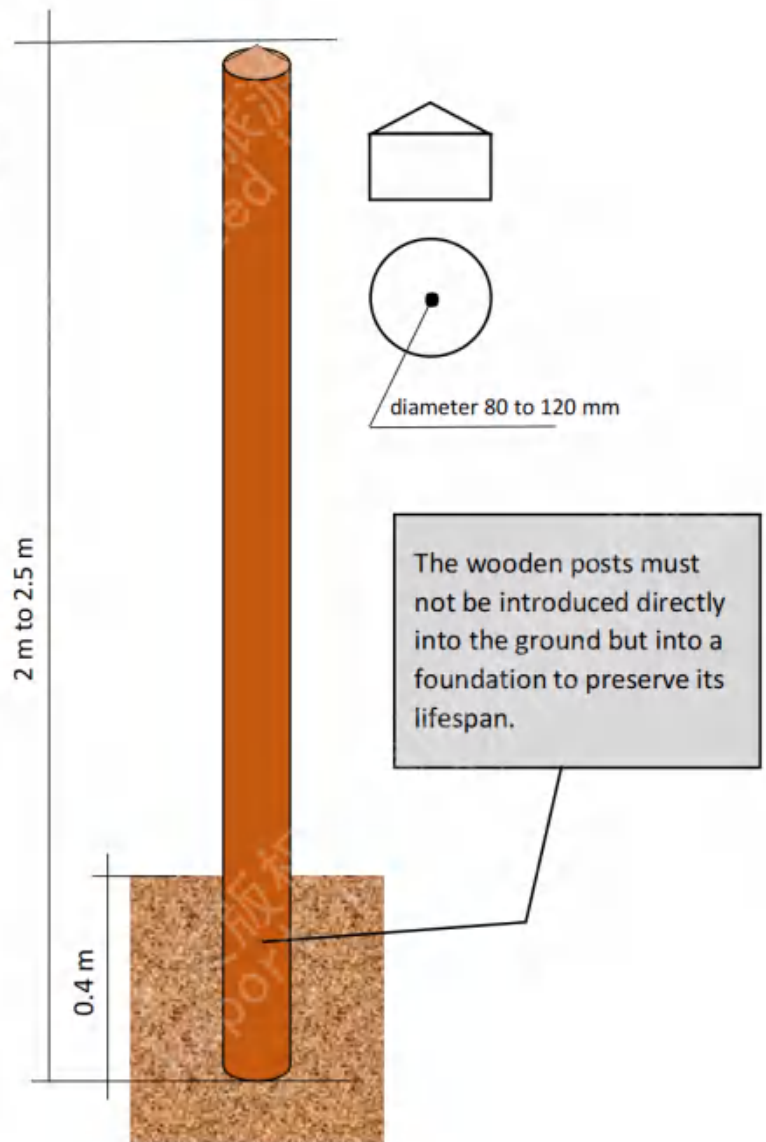



Reminder arrows. These are an intermediary between the direction arrow panels and the simple colored signs, used in places to reassure and guide hikers. These are much smaller arrows, respecting the same graphics as the larger ones, but with information simplified in pictograms. They are fixed on shorter poles or on natural supports.



PICTOGRAMS



The hiking pictograms are simplified additional information to the inscriptions on the arrow panels. They are printed directly on the arrow panels or on sticky plates. Their size is 38 mm x 38 mm. Their colors, styles, representations, order of importance vary according to the site and the trail manager. The list below is therefore not exhaustive:

Trail IDs	Animals	Botanical character	Mineralogy	Nature reserve	Route name	Route name	Route name
High mountain	Refreshment stand	Chalet catering	Refuge accommodation	Hut	Campsite	Restaurant	Cable car
Bus	Train	Mountain train	Viewing point	Orientation table	Water point	Information point	Car park
Reduced mobility	Toilet	Telephone	First aid station	Straight hike	Left hike	Fishing	Picnic area

For information of particular importance, larger pictograms can be printed on 180 mm x 180 mm panels.



The pictograms of nature reserves and regulations are generally printed on square plates from 100 to 120 mm. They are only rarely associated with trail marking and signage. These pictograms which specify the fundamentals of respect for the environment are placed at the entrance to sensitive or protected areas, and sometimes used as a reminder indicated on the trail signs and posts (preferably on square section poles). In principle, they are not managed by the person in charge of the trails but by the park operator who has his own information charter.

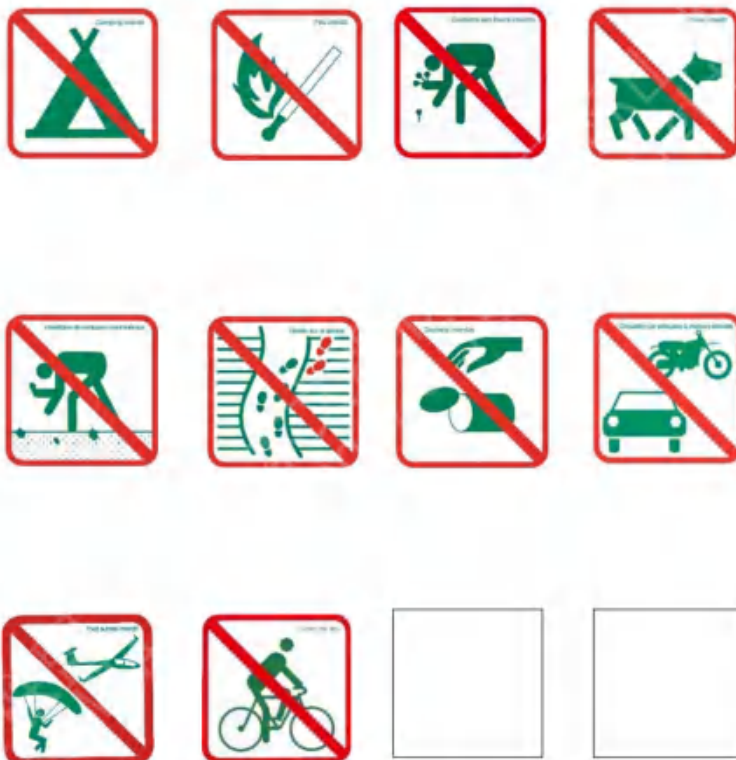



本文版权归
Report is com

本文版权归
Report is com

本文版权归
Report is com

- Alguillette des Houclies 2285 m
- Chais de Chaloux Parc Animalier de Merlet La Platière 1h45
- Parc Animalier de Merlet La Platière 0h45 1h50 2h00
- Arête de la Chalette Pierre Blanche La Platière 1h00 1h45

11

Chartreuse 47 vallées en randonnée
Généraliste - itinéraires à distance



- Green star symbol
- Red triangle symbol
- Red triangle symbol
- Red triangle symbol
- Green triangle symbol

8.5 - How to plan the marking and signage work?

Marking and signage must be carefully planned, whether it is:

- To complete the implementation of the entire project to launch a trail or network of trails;
- Or to strengthen an existing offer: improve the marking and signage of popular and high-traffic trails, clarify existing marking that is faulty or lacking in consistency, upgrade a network of routes with outdated marking, change the network layout, etc.

The marking and signage work allows the trails and routes to be finalized before they open to hikers.



CHRONOLOGY OF THE STEPS TO CARRY OUT THE MARKING AND SIGNAGE OF A ROUTE

- 1- **Carry out the initial steps:**
 - a. Target the sector in need of this work and the scope taken into account;
 - b. Identify all the ancillary paths that may be linked with the route;
 - c. Know the referent and qualified people of the project (officials, technicians, guides, volunteers or association).

- 2- **Organize a kick-off meeting to validate or determine:**
 - a. The starting points of the marking/signage circuit (car parks, cable car, bus or train station, etc.);
 - b. The objectives and the final destination (goals of the walk and remarkable points such as passes, peaks, refuges, lakes, etc.);
 - c. The paths practiced or desired (linear, loop, in which direction? Etc.)
 - d. The exact names of places and signage points (exact spelling, exact name according to maps, local or traditional "habits", etc.);
 - e. The exact altitudes of the places and indicated points (according to the cartography or a reliable "terrain" location).

- 3- **Creation of a "time and/or distance diagram" of the route from marking/signage point to marking/signage point, on the basis of all known and confirmed elements.** This is an important planning phase (and could be seen as a Master Plan for marking and signage). This very schematic sketch approximately resumes the planned route, ideally on the model of an Excel spreadsheet (ease to edit, with optional and unlimited adjustment, allowing calculations and adding of time and distance). This "time and distance diagram" thus makes it possible to know and fix the hiking times and the distances retained.

Reminder information

Reference scale:

- Ascending: 300 m of altitude difference/hour;
- Descending: 450 m of altitude difference/hour;
- In flat areas 4 km of distance/hour (on an obstacle-free walking area) or 3.5 km of distance/hour on a flat but messy path.

Example of time calculation:

- For an altitude difference of 537 m, we will have a time of $537 \times 60 / 300 = 107$ minutes, or 1h47. The retained value will be 1h50 because this value will generally be "rounded" in the direction of the increase in time (always 5 minutes by 5 minutes);
- However, we have to aware that repeated rounding can ultimately lead to an overestimated time; these rounded values should more or less compensate for each other so that the entire time from the departure to the final destination remains consistent.

EXAMPLE of time and/or distance diagram (trail of the Chamonix Valley)

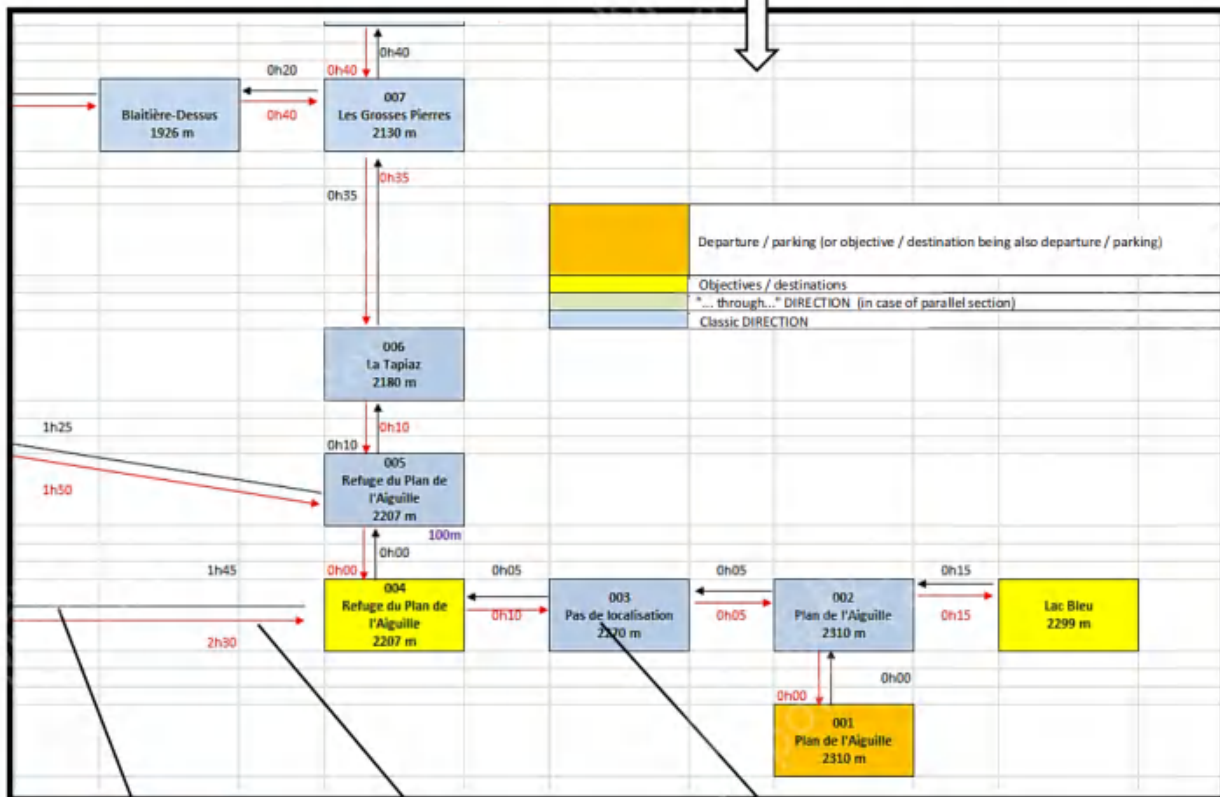
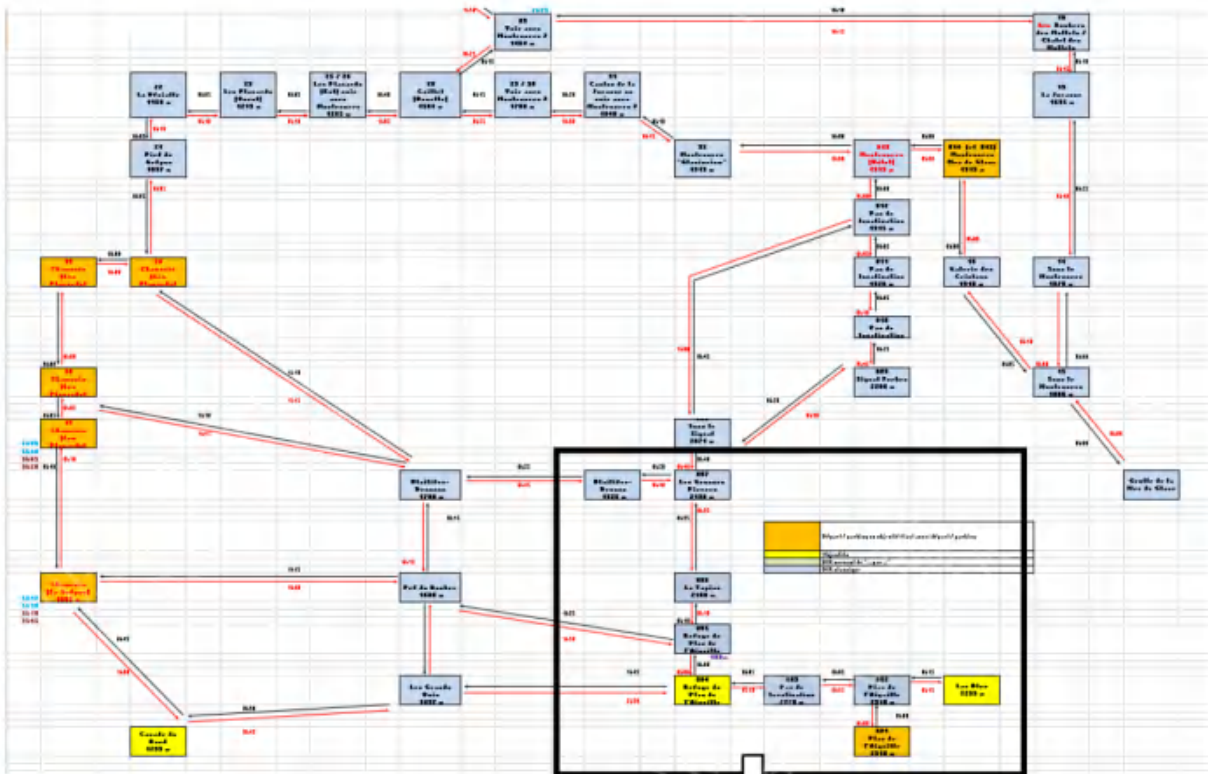

(Source: Eric Thiolière)

Descending
Direction of travel

Ascending
Direction of travel

Numbering of the point
Name of the place
Altitude

- 4- Possible validation of this "time and distance schedule" during a new meeting with the local authority (technicians, officials, etc.).
- 5- Report of all the marking and signage points on a global map to obtain an overview.
- 6- Detailed filling of "individual files" for each point with:
 - a. The content of the intersection location panels or rings (with at least the name of the place and the altitude);
 - b. The content of all directional arrow panels (with names of the destinations) and pictograms/km/time/arrow direction (left or right);
 - c. The organization of the written lines of the panels according to an ascending order by time, from the closest to the most distant, without ever emitting the final destination, and going from point to point if possible;
 - d. All color signs and pictograms to be placed on short signposts;
 - e. The number and size of support posts (diameter, height, material, etc.)
 - f. The ground anchoring system if necessary (poles);
 - g. Additional recommendations (precise indications for installation, old marking to be removed, possible access by 4x4, particular danger, etc.);
 - h. A sketch of each location with surrounding details (intersection, house, tree, rock, direction of traffic, etc.);
 - i. A photo of the intersection with materialization of the future pole or indication of the existing support;
 - j. The marking and signage point ID according to a numbering system.

Marking and signage ID engraved on the back of the panel

Each marking-signage point has its own ID number (except the simple color signs). On the panels, this number (+ a letter specific to each panel) is written on the back. This is used for management and maintenance: if a damage report is given with the corresponding ID, it will be easy to locate the problem, know which panel is concerned, and know what information is on it.

After the lost or damaged part has been remanufactured, whether it is a pole, a post or a simple color sign, a "fitter" will then go to the field to carry out the repair or the replacement.

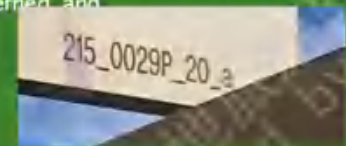

Detail of the number which includes:

- Three to six digits (depending on the country codes) corresponding to the identification of the municipality in which the point is located;
- The last two digits of the year the point was installed;
- Four to five digits/letters of the intersection number (reference which may be specific to each municipality);
- One letter per panel on the same post (letter "a" for the panel at the top of the post then in descending letters "b", "c", "d"... for the lowest).

Example of a panel number for China: "510129_20_00243_b"

Town of Dayi (29) in the municipality of Chengdu (1) in Sichuan (510)

Year of installation 2020

Intersection N° 243

« b » : 2nd panel from the top

EXAMPLES of marking colour points (1 page) and directional signage points (2 pages) sheets (2 pages)

Title of the file
COLOR SIGN POINTS

Technician

ID

Operation manager

SHEET OF BEACON POST

212_0303B
Department identification number

Reference	Marion PEYRAT
Telephone	04 50 25 22 32
Mail address	m.peyrat@ccfg.fr

Plan made by	Eric THIOLIERE	
Name of the route	Lessy lake from Paradis	
EPCI manager	Community of Faucigny Glières Towns	
Sheet creation date	15-01-2021	Installation date
Sheet modification date		Intervention date

Previous reference	
Provisional order number	11

MARKING REFERENCE	212-0303B
Town (where the equipment is located)	Petit-Bornand
Passenger vehicle accessibility	Accessibility 4X4 (for reference)
DICT to inquire	Winter drop-off

PDIPR classification	SID2
MOUNTAIN BIKE PICTOS TO APPLY	
EQUESTRIAN PICTOS TO APPLY	
Refer to specific marking sheets	

ID and name of the municipality

Plan of the point

Photo of the point to be created or modified

Sketch of the location

Photo of the location

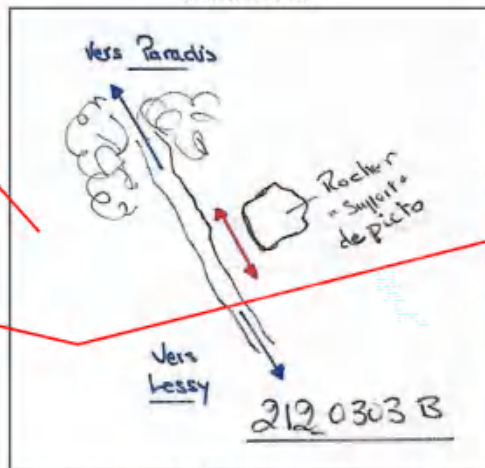

Indicate on the sketch, the orientation of the plate(s) in relation to remarkable points and by arrows on the path

Technical characteristics

Beacon post	1400	1850	No post	<input checked="" type="checkbox"/>	Concrete plinth	<input type="checkbox"/>
to order / set up	<input type="checkbox"/>	<input type="checkbox"/>				
Fastening	Iron plate	Iron pile	Sealing Iron	<input type="checkbox"/>		
to order / set up	<input type="checkbox"/>	<input type="checkbox"/>	<input type="checkbox"/>			
Pictogram supports	Simple support	90° support	Bonding plate	<input type="checkbox"/>		
to order / set up	<input type="checkbox"/>	<input type="checkbox"/>	<input type="checkbox"/>			

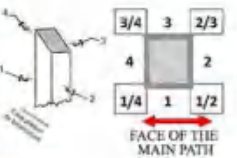

Remarks: Picto to be fixed on the large rock. Remove paint marks.

Description of operation

	On beacon post or pictogram support	No support	On beacon post or pictogram support
Qty	<input type="checkbox"/>	<input type="checkbox"/>	<input type="checkbox"/>
Face	<input type="checkbox"/>	<input type="checkbox"/>	<input type="checkbox"/>
Face	<input type="checkbox"/>	<input type="checkbox"/>	<input type="checkbox"/>
Angle	<input type="checkbox"/>	<input type="checkbox"/>	<input type="checkbox"/>
to order / set up	<input type="checkbox"/>	<input checked="" type="checkbox"/>	<input type="checkbox"/>

Detail of the marking (type, number, etc.)

(Source: Eric Thiolière and Jean-Pierre Vinadia)

Title of the sheet (2 pages)
**POSTS WITH DIRECTIONAL
PANELS**

Technician

ID

SHEET OF DIRECTIONAL POST

212_0312P
Department identification number

Operation manager

Reference	Marion PEYRAT
Telephone	04 50 25 22 32
Mail address	m.peyrat@picots.fr
Previous reference	
Provisional order number	24

Plan made by	Eric THOLIÈRE		
Name of the route	Lessy lake from Cenise		
EPCI manager	Community of Faucigny Glières Towns		
Sheet creation date	15-01-2021	Installation date	
Sheet modification date		Intervention date	

ID and name of the municipality

MARKING REFERENCE	212_0312P
Town (where the equipment is located)	Petit-Bornand
Passenger vehicle accessibility	Accessibility 4X4 (for reference)
DICT to inquire	Winter drop-off <input checked="" type="checkbox"/>

PDIPR classification	SIO2
MOUNTAIN BIKE PICTOS TO APPLY	
EQUESTRIAN PICTOS TO APPLY	
<i>Refer to specific marking sheets</i>	

Place called *Sous Jallouvre*

Plan of the point

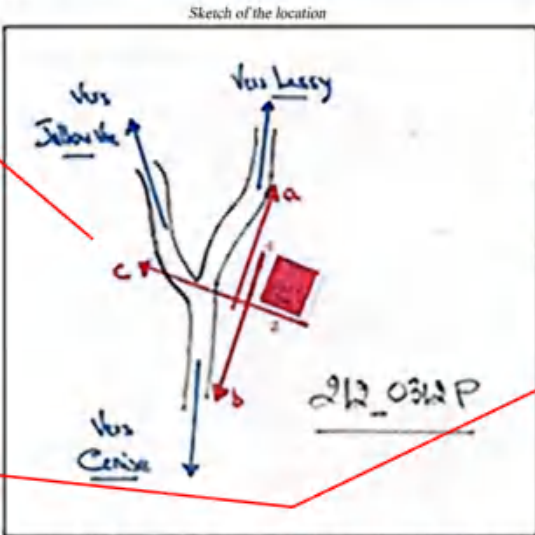

Photo of the point to create or modify with materialization of the post

Technical characteristics

Post	2150	<input checked="" type="checkbox"/>	2500	<input type="checkbox"/>	Concrete plinth	<input checked="" type="checkbox"/>
in order / set up		<input checked="" type="checkbox"/>		<input type="checkbox"/>		
Fastening	Iron plate	<input checked="" type="checkbox"/>	Sealing Iron	<input type="checkbox"/>		
to order / set up		<input checked="" type="checkbox"/>		<input type="checkbox"/>		
Pictogram supports	Simple support	<input type="checkbox"/>	90° support	<input type="checkbox"/>		
to order / set up		<input type="checkbox"/>		<input type="checkbox"/>		
Directional plate(s)	Standard plates	<input checked="" type="checkbox"/>	45° plates	<input type="checkbox"/>		

Description of operation

Remarks: **Previous marking to be removed. Winter drop-off**

OTHERS															
Qty															
Face															
Face															
Angle															
to order / set up															
to order / set up															

Pictogram (type, number, etc.)

(Source: Eric Thiolère and Jean-Pierre Vinadia)

Location and altitude **Direction of arrows** **ID**

Location plate *to order / replace* **X**

Location plate reference 212_0312P_21

Place called: Sous Jallouvre Altitude: 1868 m

Arrow panel A (top)

plate A: specify the face on which the plate is fixed 1 45° plate

Plate reference 212_0312P_21_a *to order / replace* **X**

	Distance	Time	Arrow No.
Sosay Pass		0 h 30	G
Lessy Lake (Refuge)		1 h 00	G

Line 1 **Line 2** **Line 3** **Line 4**

Arrow panel B

plate B: specify the face on which the plate is fixed 1 45° plate

Plate reference 212_0312P_21_b *to order / replace* **X**

	Distance	Time	Arrow No.
Under the Chevy Ridge		0 h 20	D
Cenise Pass		0 h 35	D
Cenise (Parking)		0 h 40	D
Les Frachets (Parking)		1 h 05	D

Arrow panel C

plate C: specify the face on which the plate is fixed 2 45° plate

Plate reference 212_0312P_21_c *to order / replace* **X**

	Distance	Time	Arrow No.
Rasoïr Pass		1 h 15	G
Jallouvre Peak		2 h 05	G

Arrow panel D

SPECIAL CASE

plate D: specify the face on which the plate is fixed 45° plate

Plate reference *to order / replace*

	Distance	Time	Arrow No.

Remarks:

(Source: Eric Thiolière and Jean-Pierre Vinadia)

- 7- **Report the numbered IDs on the point mapping** and complete it. This mapping must at least mention all the points with posts and directional arrow panels. Ideally, this mapping should exhaustively include, with their ID, all the color signs and directional posts.
- 8- The detailed plan of each color signs and directional posts makes it possible to **define the planned equipment/furniture and thus to estimate a provisional budget**.
- 9- After validation of the budget and financing, **the order can be placed** with a service provider/manufacturer identified in advance (with or without a call for tenders depending on the law of the country, the nature of the project and the project holder).
- 10- The final step before manufacturing is a **careful and final proofreading of the "ready for printing"**, detailed order document of the arrow panels, contents, pictogram plates, materials, dimensions, printing methods, etc.).
- 11- **Equipment/furniture manufacturing**.
- 12- **Reception of equipment/furniture and verification** of quantities, conformity, and quality.
- 13- **Installation fieldwork** by a service provider identified in advance (technical services of the municipality, specialized company, professional guides, group of volunteer hikers, associations, and clubs).
- 14- **Verification of the correct installation** of the signs, posts, equipment, and different furniture (with exact locations, direction of the arrows, anchoring of the poles in the ground, fixing of the panels on the poles, angle of the posts, gaps between the arrow panels, sizes of the painted color signs, general strength, etc.).
- 15- **Possible corrections** of the marking/signage and in the field to ensure perfect consistency between all the information.
- 16- **Archiving of all documents** by the trail manager and according to a defined methodology. This archiving, accessible to technicians, must be carefully preserved because:
 - a. in the case of future developments of the network of trails, it will be necessary to start again from the existing bases instead of "reinventing everything";
 - b. in the event of damage, acts of vandalism or natural deterioration, these documents will be invaluable in facilitating repair or signage/marketing replacement operations (which makes it much cheaper).
- 17- **Set up a system for receiving reports (on cards, notebooks, internet links, etc.) that can be used by trail users;**
- 18- **Have a system for an annual maintenance and for a continued high and long-term quality of the signage/marketing and of the whole trail conditions.**

EXAMPLE of reporting points and IDs on 2D and 3D maps:

- pink IDs are post points with directional arrow panels;
- yellow IDs are color painted signs.

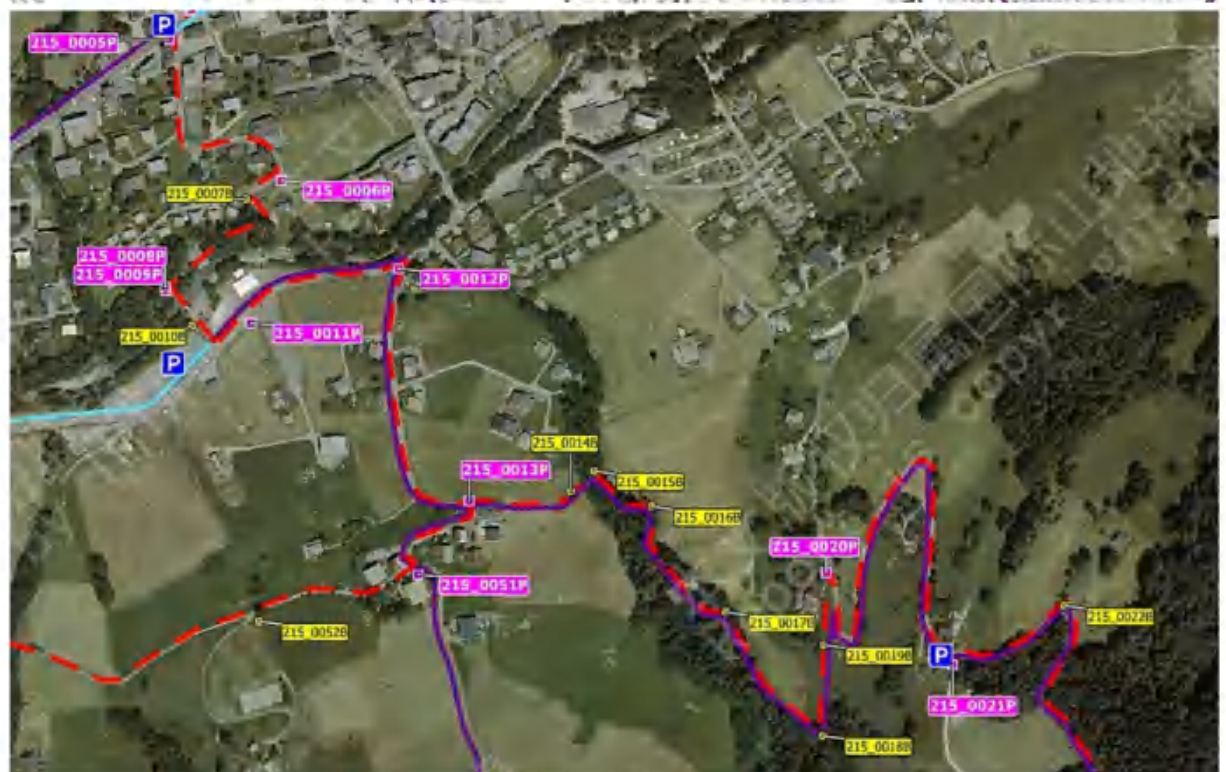
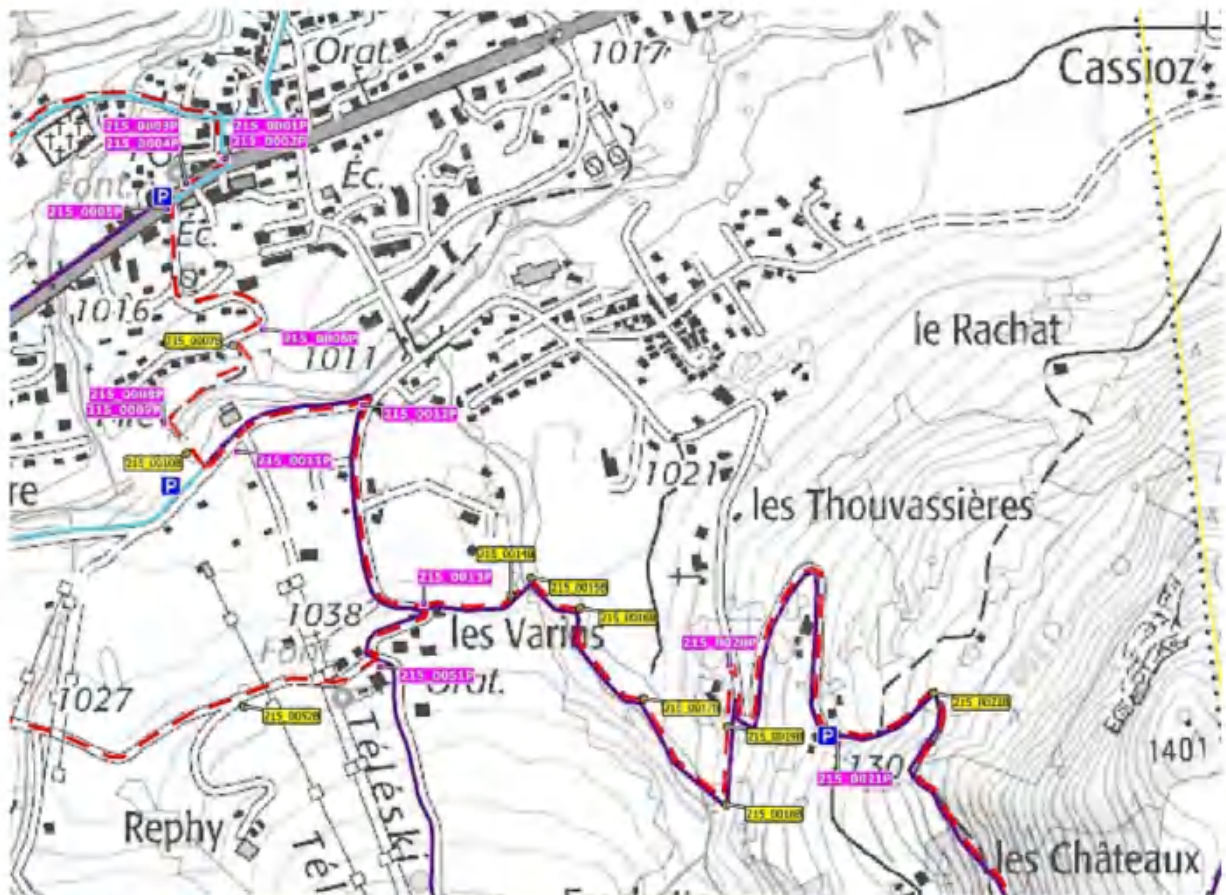

(Source: Eric Thiolière and Jean-Pierre Vinadio, Trail technical advisers for Haute-Savoie - France)



© clementchabert.fr: information furniture with the trail plan at the entrance to the Bauges trail, Alps (France)



© clementchabert.fr: orientation table at the top of Mount Semnoz, Alps (France)

8.6 - Information signage on furniture

There are two levels of information signage on the trails:

- Description of the hiking route;
- Description of a point of interest.

INFORMATION PANELS DESCRIBING THE ROUTE

These are located at the entrance of the trails on furniture generally made of wood. By using simplified mapping, the panel gives an overall view of the hiking route with:

- The location and name of the hike (if available);
- The route on a map at the indicated proportional scale of 1/25000;
- The starting point with the "You are here" pictogram and the final destination point;
- The legend of the map:
 - o The name and ID of the route: color code and number corresponding to the color painted signs
 - o The meaning of the pictograms;
- The type of circuit (loop or linear) and description: difficulty, length, walking time, drop, altitude, etc;
- Indication, if useful, of the recommended hiking direction of the circuit;
- Intermediate destination points and intermediate exits/entrances;
- Points of interest and their locations;
- Crossing points with other marked/signed trails;
- A box with a larger map that shows, in a simplified way, the entire network of trails;
- Recommendations for hikers: equipment, safety, respect for the environment;
- The regulations of the sites crossed (especially if it is a natural park);
- The emergency and rescue number;
- Phone numbers/E-mails that can be used to report any possible damage of the trail or any garbage pollution issues;
- A QR code leading to a website that promotes the hiking activity;
- Potentially the list of partners and sponsors of the trail and a mention for the organization(s) which have designed, approved, marked out and maintained this hiking network;
- Some photos, if possible;
- And in case, a label that the trail could have obtained for the high quality of the experience it provides (the IMTA triangle in the case of a IMTA project in China.

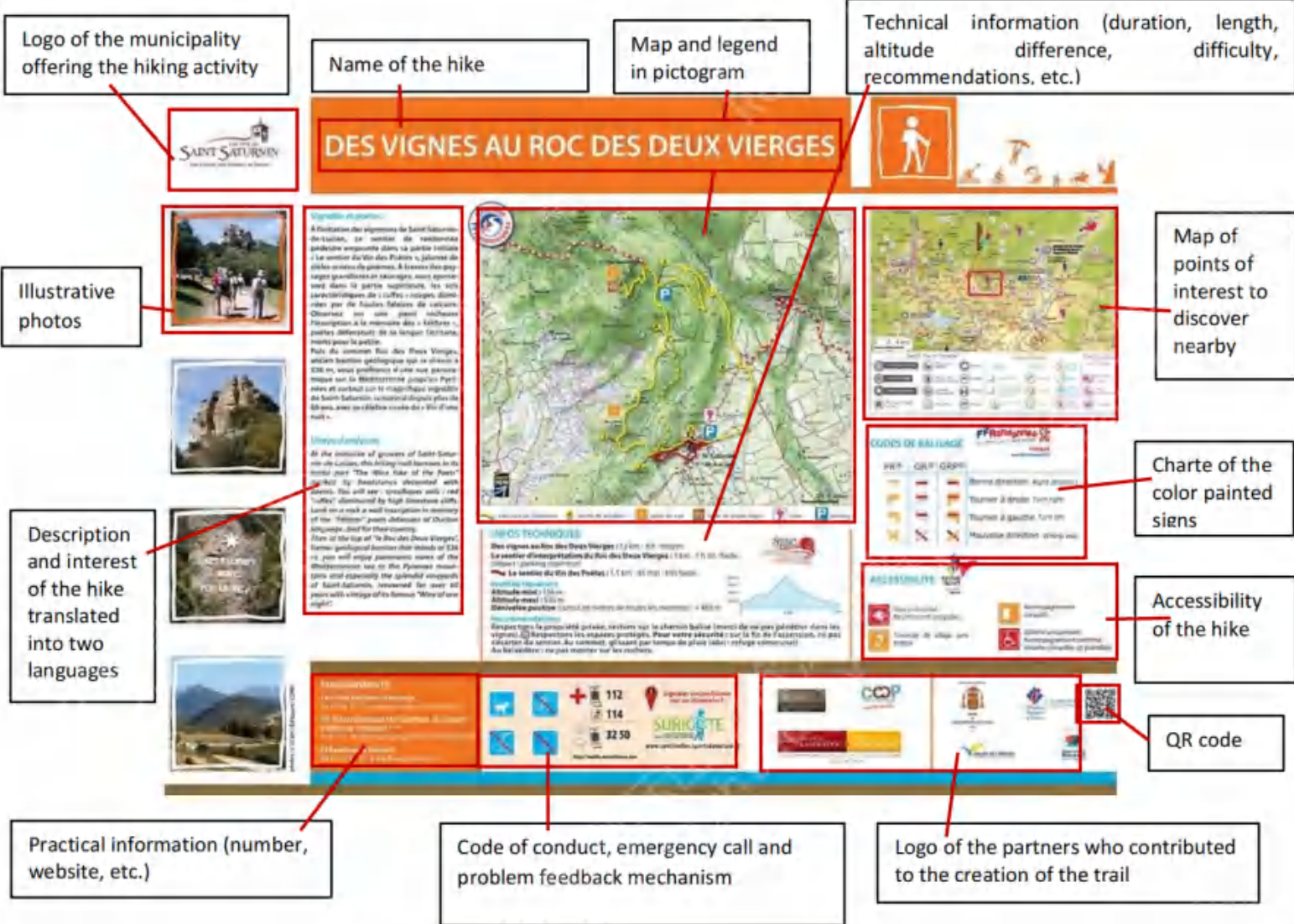

OTHER FURNITURE : INFORMATION PANELS ON POINTS OF INTEREST OR EXPLANATORY TABLES

These boards present the landscape, including names of the peaks, at landscape lookout points.



These panels present information about the immediate environment of the trail: geology, fish, tree leaves, local architecture, etc. The "discovery trails" have made these panels the basis of their offer, sometimes with an interactive concept (refer to: P2 - Chapter 6.10).





KEY POINTS TO REMEMBER

What makes good hiking signage?

Neither too
much nor
too few...

Harmonization
of the whole
trail network...

Discreet but
visible
markings/signs ...

A simple and
effective
charter...

Clear and
reassuring
signages

Signs/markings
in the right
places...

Highly informative
content



MANAGE YOUR TRAILS AND ENLIVEN THE REGION WITH HIKING

9

What does the management of a network of trails and hikes entail?

1. To ensure the sustainability of the routes, their accessibility, condition, equipment and compliance (marking, signage, maintenance);
2. To ensure it is functioning properly (coexistence with local residents and private owners, application of the agreements, possible modifications of routes, accommodation between different uses, etc.);
3. To ensure a controlled, fair and shared use;
4. To communicate with users;
5. To use digital tools to optimize the management;
6. To promote a shared, material and immaterial profitability of the activity;
7. To animate the region and participate in its development through hiking;
8. To apply an eco-responsibility charter (refer to: P1 - Chapter 12).

As an operator-manager, you are the guarantor of the quality for the offer of this hiking practice. The objectives and main tasks of the manager have been outlined and explained in the preceding chapters, in particular the planning. This last chapter summarizes this function and provides some final recommendations.

CHAPTER SUMMARY

- 9.1 Management checklist and final recommendations
- 9.2 Streamline the management with digital assets
- 9.3 Nine ideas to promote the region through hiking

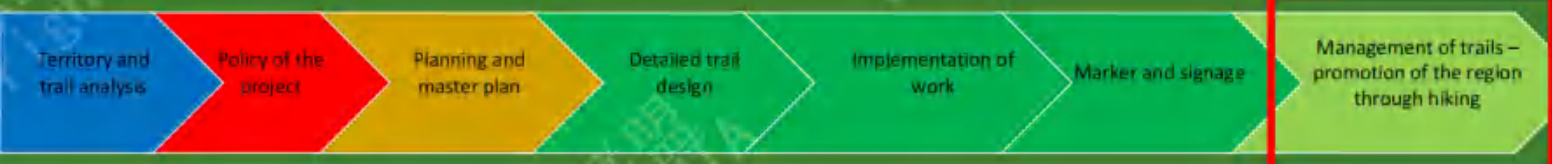



9.1 - Management checklist and final recommendations

The overall management of a trail network or a major hiking route is usually carried out by the owner, which is often a community (or a state agency). It can then mandate various participants or stakeholders to take charge of one or more missions, but the owner will nevertheless keep the responsibility of the interventions. The management work can be divided into two main categories (administrative and technical) from which everything else will ensue, in particular the quality of the experience of the trails and their profitability...

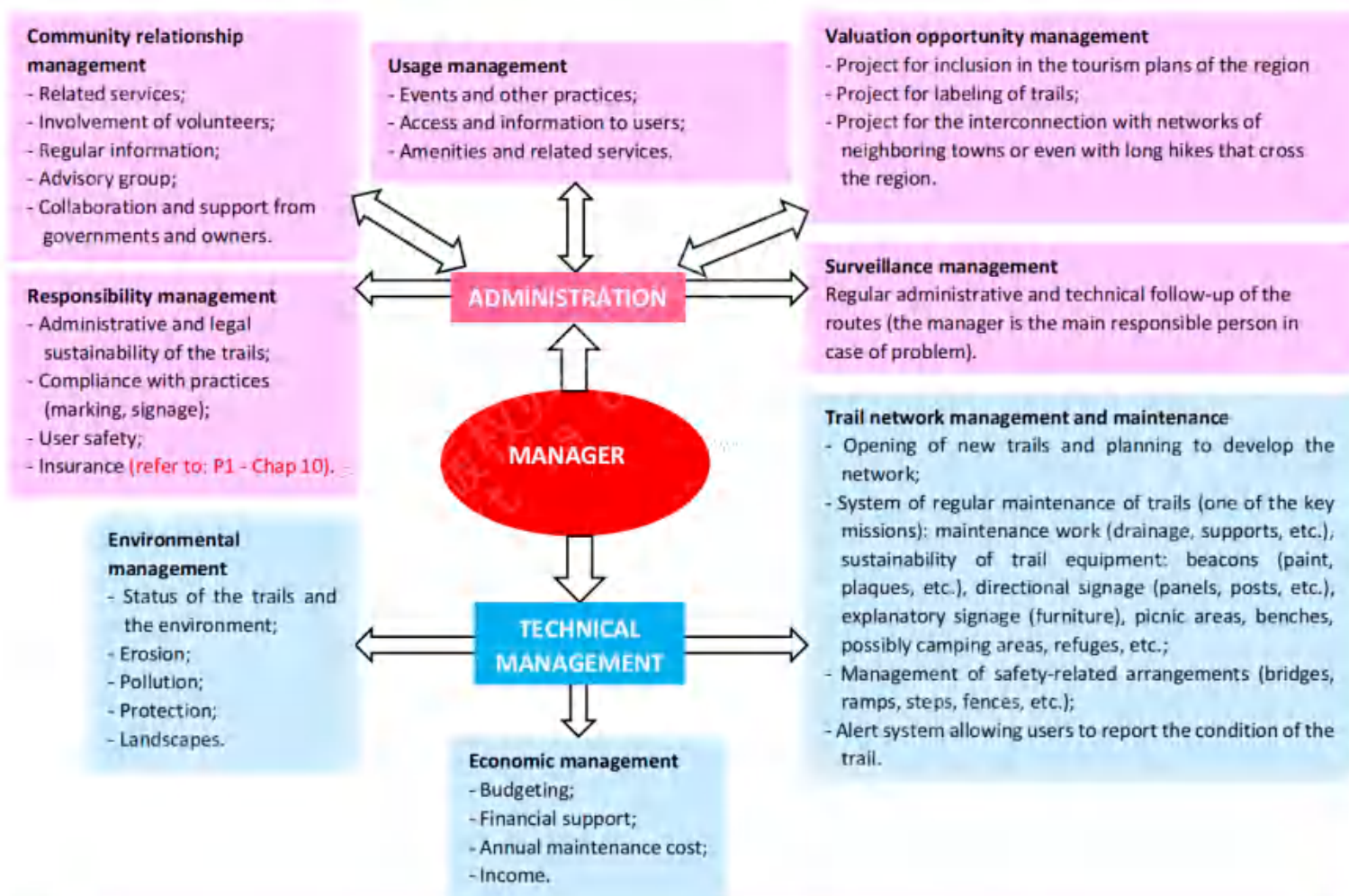

What should I do if I receive a report of a problem on a trail?

1. Check if it concerns a route for which I am the manager (if not, inform the hiker or the intermediary who submitted the report);
2. Check the anomaly on the trail and take corrective measures as soon as possible;
3. If necessary (if the problem cannot be solved quickly): inform the public that an anomaly has made the route temporarily impractical (or more difficult) - on the departure board, at the Tourist Office, etc.;
4. When the anomaly is solved, inform the person who reported the problem.



Essential element: the welcome board on a furniture at the entrance of the trails

The entrance of the trails must be given particular attention; it should have a sufficiently large and clean parking space, toilets, garbage cans and facilities with an information board, ideally in several languages, on the characteristics of the trail (refer to: P2 - Chapter 8). The quality of presentation and the style and clarity of the content is what gives the users their first impressions of your hiking offer.

The information published on the welcome panels can also be used in your communication and promotion materials.



Some ideas for promotion means

- Fliers, brochures, leaflets, etc.:



- Media:



- Topography guide-books:





Website

As it is for the entrance of the trails, the home page of the website will also be decisive and will make visitors want to further explore the website. The home pages of social networks are the ones that generate the most consultation flow: therefore, they must be attractive, clear, simple, and use high-quality visuals to best reflect the reality of your nature, landscape and hiking offer. If there is a slogan, it must be explicit (for example: "Welcome to the Andean lodges") or more conceptual (for example: "Adventure with a conscience"). The website must create its own universe, regularly publish information, encourage interactivity, and be original.

This is not about teaching you how to build or use your website or blog, but about analyzing the catch phrases of successful portals that capture hikers and nature lovers in different countries.

The entrance illustrations of the websites present the trail offering: landscapes, culture, activity, art, etc. Images of couples are often used, embodying all the profiles of hikers. All of them catch the eye with the atmosphere of the photo, the sobriety, landscape areas, natural and peaceful space. These sites reflect the spirit of hikers of all profiles by highlighting their common interest in quiet and being far away from the crowds: a strategic choice far removed from the concepts of concentrated and mass tourism, and shared regardless of the country (see the examples below).

www.myswitzerland.com, official tourist portal for Switzerland. The first tourist experience that the website offers is mountain hiking. The website is available in sixteen languages and has become one of the most popular tourist destination portals.

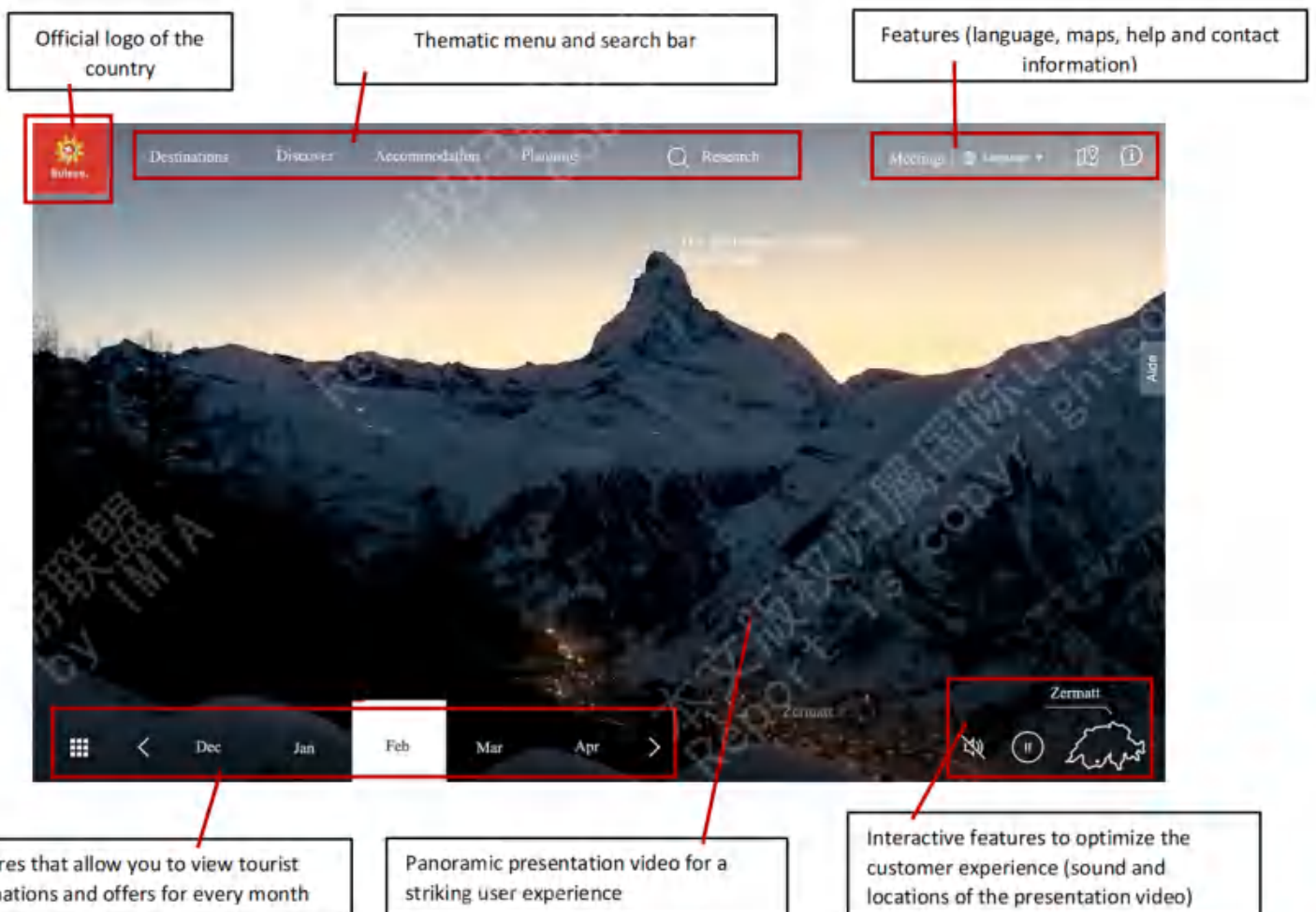

EXAMPLES of website portals specializing in hiking activities



www.visitnorway.com



Hiking in Norway

www.goverticalmountaineering.com



TREKKING & GUIDED HIKING IN SOUTH AFRICA

GUIDED TRAILS IN SOUTH AFRICA'S DRAKENSBERG, GARDEN ROUTE AND CAPE TOWN

www.albsteig.de



#AlbsteigSchwarzwald

Eine Herausforderung – entlang der sprudelnden Alb und über die Höhen vom Rhein an den Felsberg.



www.trailhiking.com.au



Australia's Hiking and Bushwalking Blog

www.serfaus-fiss-ladis.at



www.andeanlodges.com



WELCOME TO ANDEAN LODGES

THE YOUR EXPERIENCE

www.tnstateparks.com



Find a Park Activities & Events Plan a Gathering Places to Stay & Eat About the Parks



www.walkjapan.com

Walk Japan 作為健行小型導覽團的先驅者，深入鮮為人知的角落，深度認識大和文化與歷史。



www.inca1.com

INTERNATIONAL NATURE & CULTURAL ADVENTURERS

CALL TO BOOK: +1 910 820 1550

ADVENTURE WITH A CONSCIENCE

We are proud to be one of the first adventure travel companies whose corporate mission statement expresses principles of ecotourism

LEARN MORE ABOUT US



www.mongr.com

GR® 400 : le tour du volcan cantalien

Dans le département du Cantal, le GR® 400 permet d'effectuer des randonnées de week-end, autour des monts du Cantal avec 4 boucles distinctes de 20 à 40 kilomètres



www.sentiersdart.be/

Bienvenue sur Sentiers d'Art



www.wine.route.alsace

Sentier du Dragon - Interpretation trail dedicated to the vineyard

SUITABLE FOR EVERYONE

Gallery

Homepage > Walks and vineyard paths > Sentier du Dragon - Interpretation trail dedicated to the vineyard

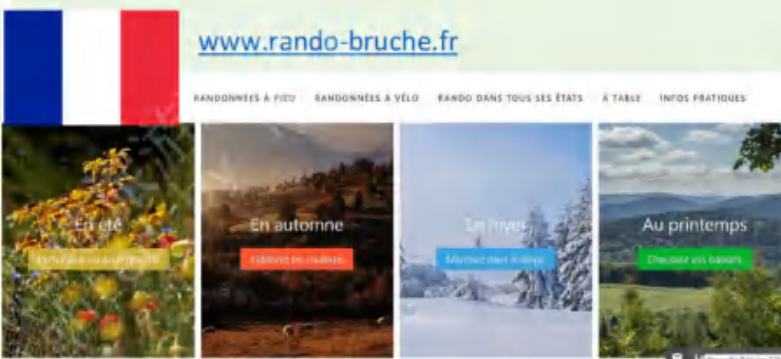

www.rando-bruche.fr

RANDONNÉES À PIED RANDONNÉES À VÉLO RANDO DANS TOUS SES ÉTATS À TABLE INFOS PRATIQUES

En été
En automne
En hiver
Au printemps



© Matrix by Pixabay.com



© Firmbee by Pixabay.com

9.2 - Streamline the management with digital assets

Connected items are taking more and more place in our society, impacting our professional, personal and sport activities and habits. Hiking is no exception, and this digital transformation is revolutionizing and transforming the activity. The intensity in the use of connected tools to venture along the trails varies between countries, cultures, hikers' profiles, their motivations, etc. Their age is an especially influencing factor. These different users can be classified into three segments:

- "Disconnected" hikers: mostly seniors over 65, who remain faithful to traditional tools (maps and guidebook);
- "semi-connected" hikers: often in the "35-65" age group equipped with basic technologies (GPS, altimeter, etc.);
- "Tech-savvy" hikers: rather the younger generations, in the "18-35" age group, strongly adept in new technologies and very attentive to technological developments (mobile application or website specifically dedicated to hiking, laptop computers, etc.).

The "connected hike" is thus gaining momentum, it lets the practitioner be informed, orientated, and to share the experiences, while also enabling the manager of the trails to optimize the offer and animate and enhance the area.

FROM HIKER TO MANAGER: WHAT WILL THE NEW TECHNOLOGY BE USED FOR?

There is a plethora of digital hiking devices that are attracting more and more users. Their forms are many and varied:

- Responsive websites;
- Mobile applications specifically dedicated to this activity;
- Hybrid devices such as paper maps, topography guidebooks, leaflets with QR codes that can be scanned with your smartphone as you travel;
- Digital audio-guides and video-guides;
- Portable GPS navigation, some of which incorporate a digital altimeter;
- Information tablets and tactile panels set up at various points along the hiking routes;
- Digital tables that immerse hikers via "virtual" 3D tours of the trails before setting of on their journey;
- And so on.

The abundance of tools makes it difficult to come up with an exhaustive list (which is growing day by day), and to understand all the functionalities that these tools cover. At the same time, they are innovative, interactive, and intuitive (please see the example with Geocaching at the end of this chapter), allowing people to engage in their activity while staying connected.

Also, this digital trend challenges and conquers many managers (national and regional natural parks, tourism promotion organizations, local authorities at local, departmental, regional levels, private operators, etc.). At the same time, managers also use these new technologies in order to optimize the management of their hiking offer, and also for the purposes of enhancing and animating their territory.

By going digital, managers can effectively support hikers in their practice, as most of these tools are made available free of charge to hikers. However, some of them include paid features (providing access to cartography with an IGN background map, for example).

Within the tool or in parallel with it, virtual communities of hikers are created. These are embodied in platforms on which it is possible to share your hiking experience (give your opinion, write comments, publish photos, etc.). They also allow the manager to develop their offer, to consider posteriori improvements and to better qualify the proposed hiking routes (development, maintenance, marking, securing of trails, etc.). In addition, these user communities can be present on public pages or private groups on social networks managed by managers or by hikers themselves (Facebook or WeChat groups for example).

In addition to the multiple uses offered by these digital technologies, hikers as well as managers also have the advantages of keeping additional traditional information circuits based on paper support (by making available, for example, description sheets of the hiking activities, downloadable as PDFs). Firstly, because not all practitioners are fervent or at ease with these innovative technologies, and secondly, because it is always more cautious to carry a paper document at the bottom of your backpack: a mobile tool may be lost or defective (alteration of battery life due to cold weather, lack of network connection, technical malfunction, etc.). These sheets can be consulted or even made available free of charge or at a lower cost directly at the reception of tourist information points (tourist offices, towns, agglomerations, reception on sites, natural parks, etc.).

MANAGE YOUR DIGITAL TOOLS

For managers, these tools have a cost both in terms of investment (tool design) and in terms of maintenance (in the sense that it requires regular updates). Staff will need to be trained to manage the "back office" of the tool and go into the field, i.e. on the trails to confront "the reality" of the offer. The data entered in the "back office" of the tool must be consistent with the reality and always up to date. To this end, managers can rely on the expertise of the designer of the tool who will guide them in developing their project and later its implementation.

These digital tools must, since their inception, be designed for the long term and the manager must figure out how they will be used and what features they should include.

Since some hiking trails can be shared with other forms of outdoor touring (horseback riding, cycling, etc.), it may be appropriate to, from the outset, plan a tool capable of covering this multiplicity and diversity of activities.

Managers must deal with an infinite number of possibilities in terms of features so that they have a tool that is most in line with their own needs (managing, promoting, facilitating), while also being in line with the expectations of the users of the tool and the trails.

Some managers choose to join forces with other stakeholders (for example the town or the nature reserve on which the trail network is located) to pool the costs (material, human resource and financial) and together promote the destination more widely through the hiking activities.

Managers must ask themselves how they can manage their hiking offers and enhance/enliven the territory through hiking with the use of digital technology? The IT tool must answer this question.

To answer this question, this "checklist", in which managers will be able to "draw" and make choices according to the three objectives pursued "manage, promote, enliven", can accompany them and represent a red wire.

MANAGE - PROMOTE - ENLIVEN THE OFFER: "MY TOOLS MUST...":



From a general point of view:

- Take the form of a responsive website or a website associated with a mobile application or a route with signs along the path with QR codes, etc. (refer to the list above): in other words, choose "the digital container";
- Address one or more targets (family, athletes, itinerant hikers, etc.);
- Available in different languages (Chinese, English, etc.) so that it can be used by international practitioners;



- Offer a selection of routes classified by theme (in the form of scripted games, treasure hunts, guided hikes, etc.), by level (easy, intermediate, difficult, etc.), by type of activity (on foot, by bicycle, on horseback, with snowshoes, etc.), by specific criteria (accessible for strollers, with a water point, etc.);
 - Propose a preselection of the hikes closest to where the user is;
 - Offer a quiz to test the users' knowledge of natural elements (flora and fauna), and historical, heritage, and cultural elements, during or at the end of the hike;
- Promote the establishment of a virtual community of users: an open platform for sharing and exchanges where everyone can publish their opinions, provide feedback on their hiking experiences, offer evaluations of the hiking routes carried out, etc., which can be used and consulted by a large number of people;
 - Provide a user guide for hikers who wish to use this tool and/or who wish to use the exchange platform.



To facilitate the preparation of the hiking activities

- Provide tourist, cultural, heritage, fauna, flora general informations, and other information of the region crossed by the trails;
- **List all the hiking routes in the network of trails;**
- Make it possible to choose a route with "a few clicks" based on predefined criteria (distance, duration, level of difficulty, etc.) so that hikers can be easily guided by their smartphone, and stay safe;
- **Allow detailed consultation of the route from a reference map which can be downloaded if needed;**
- Centralize all the information necessary for the smooth running of the chosen hike: GPS coordinates along the route, automatic guidance, real-time geolocation, detailed description of the circuit including points of interest, etc.;
- List the services related to hiking: accommodation providers (hotels, cottages, guest rooms, campsites, youth hostels, etc.), restaurateurs, transporters (luggage, people, etc.), traders (grocery stores, bakeries, etc.), sports providers such as hiking guides located near the routes, etc.
 - o A "little tip" for managers who wish to finance their tool is that they can set up an annual subscription system for service providers. They pay the amount of the subscription (set by the manager) and their services are promoted on the digital tool in a specifically created section (called for example "services related to hiking"). This dedicated section will include their business cards (full contact details, service prices and other information that they consider useful to pass on to hikers);
- Highlight the routes according to their landscape, natural, heritage and sporting interests, and according to their possible labeling.



To facilitate the course of the hike:

- Operate with and without network coverage ("offline"), offering hikers the possibility of embarking on their route and finding their way around at any time;
- Provide road guidance to get to the starting point (a car park near or at the start of the hiking route to park the vehicle may be indicated);
- Facilitate the discovery of the region by walking the trails in safety;
- Give the user the opportunity to know his progress (number of kilometers walked, number of remaining kilometers, approximate time of arrival, etc.);
- Display the GPS coordinates of the hiker in real time so that the latter is permanently geolocated;
- Inform hikers of directional changes during the walk and alert them if they deviate from the route;
- Send automatically triggered audiovisual signals aimed at drawing the hiker's attention to the various points of interest on the hiking route and offer:
 - o A summary on the historical, cultural, architectural, heritage and other aspects, explaining the different "spots" visible all along the trails;
 - o An interactive content on the environment, which is triggered when approaching the identified remarkable point (learning about nature: flora and fauna, sharpening your curiosity about an element of heritage, sharpening / improving your cultural knowledge, etc.);
- Offer multimedia contents in the form of information on points of interest (audio, video, photo, quiz, etc.), and on points of direction (audio guidance, photos, etc.) with triggering of the points according to the hiking speed of the hiker;

- Provide a section for users to give their opinion during and at the end of the hike and / or forward any comments to managers at the exit;
- Inform in real time of a difficulty or report a problem encountered during the activity (record the location of the problem, describe the difficulty by adding the corresponding photo(s) and send it to the manager or to the competent organization to intervene later and rectify the anomaly; marking error, fallen tree in the middle of a path, etc.);



To manage more specifically:

- Allow the manager to record hikers' reports, particularly on damage of trails or the nearby environment so that he/she can take measures to solve the problem;
- Perform tests on a regular basis in the field to:
 - o Check the reliability and quality of the digitized data and edited contents (descriptions of marked and up-to-date routes, registration of remarkable points, etc.);
 - o Check its proper functioning;
- Be regularly enriched with new hikes while ensuring the maintenance or upgrading of the routes that are already promoted;
- Inspire a dynamic at the scale of the region by encouraging collaboration with local experts (clubs, groups of enthusiasts, associations of volunteers, environmental specialists, etc.) to enrich the routes and create new ones;
- Contribute to improving the offer and the practices of users by identifying the most frequented departure and arrival points in order to set up parking lots, toilets, adequate equipment (for example, picnic tables and garbage cans) and complementary to the hiking activity, etc.;
- Provide decision support by aggregating the GPS tracks of hikers in order to learn about the most popular routes (to know which ones to maintain as a priority, or to detect a need for management of hikers' flows in the event of over-attendance, etc.);
- Guide political choices/decisions regarding the development of practice sites.

A last but not least important clarification. Managers must promote their digital tools to the audience. To do this, it can be useful to implement a specific communication plan and select suitable channels (posters, brochures, presentation video, guide or user manual, etc.). This plan will not only help bring the digital tools to the attention of as many hikers as possible, but also help raise awareness and encourage other managers to set up, within the framework of a partnership, a shared tool (with a trails manager of a neighboring territory, for example) and enrich it collectively.

To illustrate the above explanations, here are two links to the websites of digital tool designer-operators who work on behalf of trail and hiking activity managers:

- Géotrek : <https://geotrek.fr/index-en.html>
- Mihikes : <https://mhikes.com/>

"Geo-caching"

Geocaching is a treasure hunt during which you have to be equipped with a digital tool (a smartphone and the corresponding mobile application). This concept brings to this form of pedestrian "micro-adventure" (refer to: P1 - Chapter 7) playful, sporting and touristic dimensions.

The concept is based on a puzzle game allowing hikers with a paper notebook, their phone, a pen, a GPS and the mobile application, to learn about the surrounding heritage while walking on the trails in search of clues leading them to the treasure at the end of the journey.

This fun hike guides the participants (or group of participants) to, during the course of the key stages, recover the data indicating the progression of his course. For example, puzzle no. 1 leads him to reach an old isolated castle whose number of windows must be counted, this number then represents the first coordinate point of the treasure; puzzle no. 2 leads him to note a historical date engraved on the porch of a chapel where the second digit of the date corresponds to the second coordinate point of the location of the treasure, etc. Once all the puzzles have been solved, the "geo-cacher" enters the coordinates on the digital application to obtain the geolocation of the place where the "treasure" is hidden. The "treasure", is often a small hidden box (in a tree trunk, behind a hut, under a picnic table, etc.) in which the hiker can leave a note to indicate that he/she has reached the end of the quest. After a hiker has completed the task, he can also collect a reward (badges, figurines, etc.). For an example: Terra Aventura®: <https://www.terra-aventura.fr/en>







9.3 - Nine ideas to promote the region through hiking

- **Host episodic and eco-responsible events on the trails**
Trail running - Hiking challenges - Eco challenges - Family hiking - Relay hiking - Hiking festivals - National hiking day events, etc. This potentially massive use of trails must be occasional and subject to a rigorous ecological charter both for the organizer and for the participants (refer to: P1 - Chapter 12);
- **Organize a big hiking-themed event every year**
Hiking fairs for professionals and practitioners - seminars - congresses - Nature, culture & hiking film festivals, etc.;
- **Organize "provincial (or national) hiking meetings"** with relevant administrative services, tourist offices, trail managers, clubs, and so on, to build relationships, mutualize the promotion, discuss practices, etc.;
- **Establish a hiking club in the name of the most famous site or trail**
With an annual calendar of events - group outings;
- **Establish a "young" holiday camp** on hiking and nature, personal development in nature or other themes related to hiking (refer to: P1 - Chapter 8);
- **Organize an annual hiking activity for specific professional sectors:**
Journalists and media (for media coverage) - receptionists of tourist offices and accommodation providers (so that they can better promote the offer to tourists), etc.;
- **Organize learning and training programs**
Introduction to hiking - guide training - environmental awareness and education - school trips and establishment of a class in partnership with the Education Administration, etc. (refer to: P1 - Chapters 8 and 10);
- **Organize hiking touristic offers with frequent visits to economic players of the territory**
Mountain inns, farms, restaurateurs, village hoteliers, artisans, traders of local products, etc. (refer to: P1 - Chapter 8);
- **Open new trails**
Organize inauguration and opening ceremonies with local authorities, media events, hiking events for all, etc.



© Serge Koenig: start of the 2018 UTMB race in Chamonix (France)



© Armand Ducornet: group on the march for EuroRando 2016 of the European Hiking Federation (France)

White Cliffs Walking Festival
27th August to 1st September 2020



National Trails Day
CORNER CANYON BEAUTIFICATION BASH



TRAIL DU 17 AU 20 OCT. 2019



ARCTIC HIKING FESTIVAL
50 Miles, Greenland July 27 - August 1 2015



ONLY THE ESSENTIAL

A Hike from Mexico to Canada on the Pacific Crest Trail

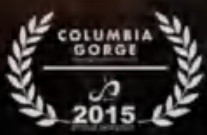



KEY POINTS TO REMEMBER









BIBLIOGRAPHY AND REFERENCES THAT INSPIRED THE WRITING OF THE IMTA GUIDE

General

- « *National Strategy for a Sustainable Trail System* » by US Department of Agriculture Forest Service (November, 2017)
- « *Why Trails – 2020 Edition* » by American Trails
- « *Particularism vs. Universalism in Hiking Tourism* » by University of Haifa, Israel, Collins-Kreiner & Kliot (2015)
- « *Outdoor Recreation Trends and Futures* » by Ken Cordell, US Department of Agriculture Forest Service (2010)
- « *Outdoor Recreation Participation in the United States-Projections to 2060* » by Bowler, Askew, Cordell, Betz, Zarnoch & Seymour of US Department of Agriculture Forest Service (2010)
- « *Universal Access and Shared Use Paths – Design, Management, Ethical, and Legal Considerations* » by Pennsylvania Land Trust Association (November, 2014)
- « *La Valorisation du Tourisme de Randonnée dans les territoires ruraux* » par Commission Européenne Direction Générale de l'Agriculture et LEADER (Mars 2001)
- « *La création d'un produit touristique de randonnée thématique* » par JL Rouquet, Office National des Hautes Alpes (Avril 1994)
- « *European Wandervereinigung Wegecommission 1969-2013* » by ERA-EWV-FERP (2019)
- « *La fédération au service des collectivités territoriales* » par Fédération Française de la Randonnée Pédestre (2005)
- « *Rapport Annuel 2017 des sentiers en Suisse* » par Suisse Rando
- « *La valorisation du Tourisme de Randonnée dans la Région de Crans-Montana* » par L. Krembel de la Haute Ecole Valaisanne, Filière économique, Suisse (Décembre 2004)
- « *L'attractivité du Territoire Touristique* » par OD Galarneau, Maître en sciences géographiques (2015)
- « *Le guide du droit du chemin* » de Fédération française de la Randonnée Pédestre

Ecology

- « *Designing more sustainable hiking trails* » by Review of Yale School of the Environment (2020)
- « *Sustainably Designed Trails: Recent Recreation Ecology Findings on Design Factors Affecting Soil Loss* » by USGS Science for a changing world (2018)
- « *Assessing ecotourism tourism potential of hiking trails: A framework to incorporate ecological and cultural features and seasonality* » by Santarem, Silva, Santos in Tourism Management Perspectives (October, 2015)
- « *National Strategy for a Sustainable Trail System* » by Forest Service, United States Department of Agriculture (October 2017)
- « *Ecologie et Humanités* » par la Revue interdisciplinaire d'Humanités de l'Ecole Doctorale Montaigne (N°13, 2018)
- « *Culture, Environnement et Société : Retour du débat sur la Wilderness* » par Christian Barthod (2010)
- « *Syndrome de manque de nature* » par Réseau Ecole et Nature (Juin 2013)
- « *Liste en place de la charte des engagements éco-responsables des grands événements sportifs internationaux au sein de l'UTMB* » par EPGM et Université Savoie Mont-Blanc, de J.Pijourlet (Septembre 2017)
- « *Rapport d'impacts UTMB* » par Université Savoie Mont-Blanc, Asters Conservatoire d'Espaces Naturels Haute-Savoie, Commission Environnement d'UTMB, de M. Bonnin (Juillet 2018)
- « *Solid Waste Management in Sagarmatha National Park, Nepal* » by Universität Wien (2013)
- « *Sagarmatha National Park, Adaptation to Climatic Change* » by University of Illinois at Urbana-Champaign, Chandana Konidala (2017)
- « *Accès à la nature – Résolution de la FERP* » by www.era-ewv-ferp.org (2016)
- « *Mise en place de la charte des engagements Eco-Responsables des grands événements sportifs internationaux, l'exemple de l'UTMB® Mont-Blanc* » mémoire Master2 – Université Savoie Mont-Blanc by Jules Pijourlet
- All the references of « *La littérature universitaire* » ([refer to: P1- Chapter 12.1](#))

Market research

- « *Les clientèles de Tourisme de randonnée pédestre – étude de marchés français, allemand et néerlandais* » par Atout France (Mars 2019)
- « *Etude des clientèles, des lieux de pratique et des retombées économiques et sociales des activités physiques de plein air* » par la Chaire de tourisme Transat ESG UQAM Canada (Octobre 2017)
- « *Tourist Special Interest, Walking and Hiking* » by New Zealand Tourism (February, 2014)

Economic profitability of trails

- « *Benefits of Trails & Greenways* » by National Park Service (January 2008)
- « *The Economic Benefits of Trails* » by American Hiking Society (February 2014)
- « *Hiking Trails in America, pathways to Property* » by American Hiking Society (June 2015)
- « *Examination of benefits sought by hiking tourists: a comparison of impact-range performance analysis and impact asymmetry analysis* » by Asia Pacific Journal of Tourism Research (July, 2019)
- « *Fondements économiques des chemins de randonnée pédestre en Suisse* » par Office fédéral des routes OFROU et Suisse Rando
- « *The Value of Hiking, Economic benefits of hiking and non-motorized outdoor recreation* » by Washington Trails Association & University of Washington Political Science Department, J.Frantz (August 2007)

- « *The Economic Influence of Human Powered Recreation in Montana's Custer Gallatin National Forest* » by Outdoor Alliance & MRG (2018)

Inventory of trails and Master Plans

- « *Sidewalk and Trail Master Plan for Unified Government/Kansas City, Kansas* » by Health Care Foundation (July, 2012)
- « *Chuckanut Mountain Trails Master Plan* » by Whatcom County Parks & Recreation (June, 1996)
- « *Bountiful Trails Master Plan, Utah* » by Bountiful East. 1847 (October, 2019)
- « *Trails Master Inventory by City of Corona* » by (May, 2019)
- « *Pinal County Open Space and Trails Master Plan* » by Logan Simpson Design INC (October, 2007)
- « *Kitchener City Multi-use Pathways and Trails Master Plan* » by MMM Group & Ecoplans (May, 2012)
- « *Master Plan of Fairywood, Pengzhou* » by Dianeige (2011)
- « *Town of Needham, Trails Master Plan* » by Conservation Commission, Park&Recreation Commission, School Committee (November, 2008)
- « *Park, Trails & Open Space Master Plan* » by Forest Lake City (June, 2014)
- « *Public Draft Parks & Trails Master Plan* » by Placer City (March, 2019)
- « *North Cariboo Trails Inventory an Master Plan* » by City of Quesnel (December, 2017)
- « *Regional Trails Plan* » by Spokane County (July, 2004)
- « *Trails Master Plan 2013-2023* » by City of Astoria, Oregon (2013)
- « *Trails Master Plan* » by Town of Parry Sound by Design (2015)
- « *Trails Master Plan* » by District of Squamish
- « *Parks & Trails Inventory & Needs Assessment* » by Municipality of North Cowichan (2015)
- « *Johnson County Trails Master Plan* » by Griffin Collaborative Designs, LLC (August, 2019)

Layout, maintenance and markup

- « *Aménager un sentier de randonnée sur sa commune* » par Tourisme Morbihan (2009)
- « *Les itinéraires de Randonnée, conception : enjeux et principes* » par Fédération Française de la Randonnée Pédestre
- « *Guide terrain : saines pratiques d'intervention en forêt privée* » par Nouvelle Edition
- « *Création et Valorisation de Chemins de Randonnée sur la Communauté de Communes de Frontonnais* » par Centre Universitaire Champollion et Office de Tourisme de Fronton (2014/2015)
- « *Normes en aménagement de sentier* » de Rando Québec (2020)
- « *Comment aménager vos sentiers pour l'interprétation* » par Ministère de l'Environnement Paris (1988)
- « *Concevoir un sentier d'interprétation – Guide pratique* » par Parc Naturel Régional des Ardennes (2015)
- « *Aménagement de sentiers de randonnée pédestre et gestion des risques* » by Rando Québec
- « *Sentiers pédestres : revêtement à éviter* » VLP-ASPAN n°5/10 de Spori & Bühlmann
- « *Construction et entretien des chemins de randonnée pédestre* » de l'Office fédéral des routes (OFROU) et Suisse Rando (2008)
- « *Aménagement, évaluation et entretien des sentiers pédestres au Québec – Normes et critères* » de la Fédération québécoise de la marche (Septembre 2004)
- « *Guidelines for trail planning, design and management* » de Australia TRC Tourism Pty Ltd
- « *Manutenzione dei sentieri, manuale tecnico* » by Parco Naturale delle Alpi Maritime & Parc National Mercantour
- « *Développement d'un outil de diagnostic et de suivi de l'État des sentiers pédestres du Parc d'environnement naturel de Sutton, Québec* » par Université de Sherbrooke, Brice Caillié (Juin 2017)
- « *Balisage et signalétique de randonnée* » par le Finistère (Ed 2018)
- « *Charte départementale de Balisage et signalétique de randonnée* » par Pyrénées Orientales (2016)
- « *Charte signalétique des réserves naturelles* » par Ministère de l'Environnement Paris (1993)
- « *Signalisation des chemins de randonnée pédestre* » par Office fédéral des routes (OFROU) et Suisse Rando
- « *La charte officielle du Balisage et de la Signalisation* » par Fédération Française de la Randonnée Pédestre (2019)
- « *Charte technique et graphique* » par Fédération Française de la Randonnée Pédestre (2019)
- « *Guide technique Balisage & Signalétique de Sentiers de Randonnée Pédestre* » par la ville de Rouyn-Noranda (Août 2017)
- « *La signalétique pour les activités de pleine nature* » par la Lozère

Labeling and various

- « *Guide pratique de cotation des randonnées pédestres* » par Fédération Française de la Randonnée Pédestre (2015)
- « *Mode d'emploi de la procédure d'un PR en itinéraire Labellisé FFRandonnée* » par Fédération Française de la Randonnée Pédestre (2018)
- « *Mémento de formation Aménageur* » par Fédération Française de la Randonnée Pédestre (2011)
- « *Procédure d'homologation d'un itinéraire en GR ou GR de Pays* » par Fédération Française de la Randonnée Pédestre (2015)

CONTACTS :

IMTA

Guosong Liu: directeur

ID Weixin: scun2015

liu@imtaweb.org

Jiangsu Panda International Tourism Development co., Ltd

Xiaoning Wang: CEO

ID Weixin: worldtrip

Mobile: +86 18662438848

w@outdoor-chine.com

Author

ID Weixin: sergekoenig

sergekoenig8848@yahoo.fr

sergekoenig@imtaweb.org

Mobile: +33 630984777